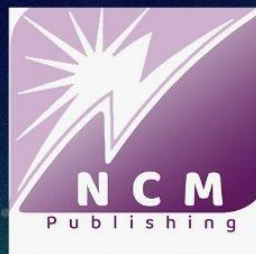

ORGANIZATIONAL BEHAVIOR
SOCIAL ENVIRONMENT
HUMAN RESOURCES
FINANCE
MARKETING
ECONOMICS
DIGITALIZATION
MANAGEMENT
ORGANIZATION

CONTEMPORARY
EXPLORATION OF
SOCIAL SCIENCES IN THE
POST PANDEMIC ERA - 1

Editors

Assoc. Prof. Dr. Muhammad Ali Tarar

Assoc Prof. Dr. SevdA Aghamirza Aliyeva (Ahadova)



Contemporary Exploration of Social Sciences in the Post Pandemic Era - 1



Editors

Assoc. Prof. Dr. Muhammad Ali Tarar
Assoc Prof. Dr. Sevda Aghamirza Aliyeva (Ahadova)

Published by: NCM Publishing House

Publishing Date: 23.07.2023

ISBN: 978-625-99157-2-2

Copyright © The publishing rights of this book belong to **NCM Publishing**. The legal responsibility of the chapters belongs to the authors themselves. Except for the quotations to be made in accordance with the academic ethical rules and the short quotations to be made for promotional purposes, all or part of it cannot be printed, published, copied, reproduced or distributed electronically, mechanically or in part without the written permission. The authors are responsible for the content of the papers(chapters).

Contemporary Exploration of Social Sciences in the Post Pandemic Era - 1

Publication No:	14
Editors	<i>Assoc. Prof. Dr. Muhammad Ali Tarar</i> <i>Assoc Prof. Dr. Sevda Aghamirza Aliyeva (Ahadova)</i>
Cover Designer	<i>Mr. Kerim KARADAL</i>
ISBN	978-625-99157-2-2
Publisher Certificate No	51898
Publisher Type	International Publishing House
Release Date	2023



CONTACT

Phone: +90 554 888 1471
e-mail: ceocongress.info@gmail.com
www.ceocongress.org

LIBRARY INFORMATION CARD

Tarar, Muhammad Ali and ; Aghamirza Aliyeva (Ahadova), Sevda; Editor, 1, 2023. **Contemporary Exploration of Social Sciences in the Post Pandemic Era - 1**. NCM Publishing House, Bursa.
Language: English
Editors: Assoc. Prof. Dr. Muhammad Ali Tarar; Assoc Prof. Dr. Sevda Aghamirza Aliyeva (Ahadova)
ISBN: **978-625-99157-2-2**

CONTENTS

Chapter	Title and Author	Page
Chapter 1	The Impact of Self Identities, Perceived Country Image, And Institution Image on Intention To Choose Study Destination Kim min SUK Ir. Amelia Naim INDRAJAYA Ir Firdaus Basbeth MM	5
Chapter 2	Higher Instruction Human Resources Management (HRM) Hones and Information Administration Specialist Presence Adi Muhajirin Sumaryono Dewi Puspaningtyas Faeni	18
Chapter 3	The Effect of Word of Mouth And Online Reviews on Consumer Trust : (Case Study in Erigo) Shinta Amelia Putri Muhammad Choirudin Naufal Yudha Irwanto	30
Chapter 4	Intellectual Capital Determinants of Knowledge Sharing Through Organizational Capital of Village Officials in Sungai Penuh City Ferry Siswadhi Mauledy Ahmad Dewi Puspaningtyas Faeni	39
Chapter 5	Financial Analysis in Industry PT Telkom Indonesia Demmy Puspita SUGIADI Wiwiek Mardawiyah DARYANTO	53
Chapter 6	A Counseling Teacher in Narrative Photography Mrs. Erlina Novianti Ms. Syamila Tartila Sofian Mrs. Silviana Amanda Aurelia Tahalea Mrs. Asih Resto Dewanti	66
Chapter 7	Digital Transformation Impact on Financial Performance of Telecommunication Industry in Indonesia during and after Pandemic Covid-19 Feby SALLYANTO Wiwiek Mardawiyah DARYANTO	82
Chapter 8	The Effect of Workload And Work Environment on Employee Performance with Work Stress as a Mediating Variable. As Seen in the Evidence of PT Matra Perkasa Utama Ir. Amelia Naim INDRAJAYA Medyna ROESLY SE. Ak.	99
Chapter 9	The Impact of Television Media Advertising, Product Quality, and Price on Consumer Purchasing Decisions for Indosat Service Providers in Indonesia Sugiyono Lisna Nurpida Dewi Puspaningtyas Faeni	111

Chapter 10	Maritime Sector for National Economy (Competitiveness) Through Connectivity: A Systematic Literature Review Analysis Muhammad Zilal HAMZAH Eleonora SOFILDA EFEREDO	126
Chapter 11	Diversity on Productivity: Anything for Efficiency & Effectiveness? Samuel PD ANANTADJAYA Irma M NAWANGWULAN	140
Chapter 12	The Influence of Innovation Capabilities and Market Response Capabilities on Supply Chain Financing Adoption Moderated by Supply Chain Integration (In the Manufacturing Industry Joined in IPOMS) Mrs. Tasya AMARTA Timotius Febry CHRISTIAN	152
Chapter 13	The Effect of Using Sap in Business Intelligence Yohana Oktavia Yonathan Hakim Mrs. Dewi Puspaningtyas Faeni	166
Chapter 14	The Impact of Environmental, Social, and Governance Performance on The Financial Health and Firm Value of The Publicly Listed Firms at Indonesia Stock Exchange Riko RANGKUTI Roy H. M. SEMBEL Melinda MALAU	174
Chapter 15	The Effect of Tax Avoidance and Capital Structure on Firm Value (Empirical Study of Financial Companies Listed on The IDX For the 2017 – 2021 Period) Ruly Rakasiwi Amor Marundha Uswatun Khasanah	191
Chapter 16	Revolutionizing Digital Transformation: The Rise of digital banking in regional development banks in Indonesia EKA RIZKI SUKMADEWI, SS Ir. Amelia Naim INDRAJAYA, MBA	208
Chapter 17	The Effect of Market Risk, Market Capitalization, Bond Rating, and Profitability on the Stock Return of Companies Listed in PEFINDO Investment Grade Index 2018 – 2022 with Company Age as The Moderating Variable CHAIRINI Roy SEMBEL Melinda MALAU	219
Chapter 18	Fairness in Obtaining Repurchase Intention Through Goal Achievement Karunia Fransiska Yolanda Masnita Kurniawati	225

	Renny Rizqiani	
Chapter 19	Employees' Performance Enhancement Based on Collaborative E-Learning and Mediated by Training in Bank Syariah Indonesia: A Human and Organization Development Perspective Dewi Puspitaningtyas Faeni Sri Wulandari, S.T Rachmat Pramukty, M.Si	238
Chapter 20	Design of Research Reporting and Data Collection Information System at Public University Using The Design Thinking Method Ms. Kendry Ayu Laksana Ms. Ika Raharja Salim Wirawan E. D. Radianto	254
Chapter 21	The Impact of Heat waves on Food Security and The Role of International Environmental Law Amalia ZUHRA Arlina PERMANASARI Siti Hafyah IDRIS Mr. Muhammad Falih NASYWAAN	271
	Editor's Biographies	291
	<i>Assoc. Prof. Dr. Muhammad Ali TARAR (Ph. D Rural Sociology)</i>	
	<i>Assoc Prof. Dr. Sevda Aghamirza Aliyeva (Ahadova)</i>	
	NCM Publishing House Certificate	294

CHAPTER 1

The Impact of Self Identities, Perceived Country Image, And Institution Image on Intention To Choose Study Destination

Kim min SUK

IPMI/IPMI, Jl. Rawajati Timur I No.1, RT.3/RW.2, Rawajati, Kec. Pancoran, DKI JAKARTA/JAKARTA SELATAN,
12750
minsuk@ipmi.ac.id

Ir. Amelia Naim INDRAJAYA

IPMI/IPMI, Jl. Rawajati Timur I No.1, RT.3/RW.2, Rawajati, Kec. Pancoran, DKI JAKARTA/JAKARTA SELATAN,
12750
amelia.naim@ipmi.ac.id

Ir Firdaus Basbeth MM

BINAWAN /BINAWAN, Jl. Dewi Sartika No.25-30, Kalibata, Kec. Kramat jati, Kota, DKI JAKARTA/ Jakarta Timur,
13630
firdaus.basbeth@binawan.ac.id

ABSTRACT

Demand for higher education in developing economies keeps increasing since more people realize the benefit of advanced education qualifications for their future. According to some studies factors that affected Asian students in selecting study destinations in foreign countries are expected benefits from studying abroad, push factors from their home country, perceived destination image, perceived institution image, and marketing information channel, however, not much is known about the mediating effect of Country Image and Institution Image in the effect between Self-identity and Intention to choose study destination, The objective of the study is to investigate the role of country image and institution image, especially context of Indonesian and South Korean student's since a lot of studies focus on Asian in general and not specifically on Indonesian student to South Korea and vice versa. The data was taken from students in Jakarta and Seoul representing both countries' capital cities. The sample size was 49 for each country formed from July to September 2021. The data were analyzed using SPSS v25 and Smart PLS3. The result indicated that Country Image and Institution image fully mediate the effect of Self-identity on student intention to choose a study destination. The practical implication is for the marketers of international higher education and government of the host country to focus on the creation of positive country destination and institution images, whereas the theoretical contribution is a comprehensive examination by examining Country Image and Institution Image as a mediator between Self-identity and Intention to study in a foreign country using social identity theory.

Keywords: Self-identity, national Pride, Consumer Cosmopolitanism, Country Image, Institution Image, Intention to study in South Korea, Intention to study in Indonesia

1. INTRODUCTION

Since more people are becoming aware of the advantages of advanced education credentials for their future, demand for higher education in developing economies continues rising. Additionally, it is influenced by the nation's economic expansion and the accessibility of financial assistance. (Lee, Yuan, Hwang, & Kim, 2012). Beginning in the middle of the 1970s, when governments of independent nations funded talented citizens to study cutting-edge information from developing economies, there has been a dramatic rise in the mobility of international students. (Chan, 2012). In 1975, there were 0.8 million students studying overseas. This number rose to around 5 million in 2016 with a current annual growth rate of 6%. (OECD, 2018)

When considering studying abroad, potential students may prefer to pick a location that complements their personality to make the transition to the host nation's culture easier. Due to their cultural orientation and flexibility, some Indonesian students may have difficulty adjusting to life overseas. (Mukminin, Fridiyanto, & Hadiyanto, 2013). It can be explained that students must adapt to the new surroundings and educational system in the host nation and host institution when they leave their native country to pursue their studies. If they have trouble adjusting, they might not appreciate their time there and it might have an adverse effect on their academic performance. (Mustaffa & Ilias, 2013).

By examining the relationship between self-identities, country image, and institution image in the context of a comparison study of higher education between students in the cities of Seoul and Jakarta, this study aims to examine the phenomenon of the intention of Indonesian students majoring in business management to choose a study destination.

Based on the justification provided, this study will discuss the variables influencing Indonesian students' decision to pursue an international education, particularly in the field of business management, and will compare the situations of Indonesia and South Korea. The study will identify and describe the parallels and divergences between the characteristics of the two nations as well as investigate the impact of self-identity, country image, and school image on the decision to pursue further education. In the end, this study will attempt to discuss the future challenges and opportunities facing business management schools in Jakarta to draw more international students from Korea. It will do this by learning from the current survey data from an undergraduate student majoring in business management in a few locations in both countries.

LITERATURE REVIEW

The main constructs and their relationships, as well as a review of the most pertinent studies and books, were examined. Empirical investigations then provided a description of the relationships between the variables in order to create the research model. The use of the host country image and institution image as its suggested mediating role was inserted in the relationship between self-identity and the desire to choose a study location after analyzing the gap in the previous analysis. Once all of the interactions between the factors have been examined, the hypothesis and model will then be created.

Self-identity (SI)

Social identity theory explains how self-identity affects conduct. According to the theory, people conduct self-confirmation by showing others how they perceive themselves. The personal self, relational self, and communal self are the three components of one's self-concept, according to Brewer and Gardner (1996). The interpersonal self, which is further broken down into the relational and collective selves, is the main center of social identity theory.

Country image

The country image is a tool used by intentional marketing literature to describe why consumers buy products from other countries. Government and corporate organizations must control their nation's reputation and use branding techniques to improve it. In order to instill a favorable perception of the nation in the thoughts of consumers, this strategy is carried out by developing a strong brand identity (Klein, Völckner, Bruno, Sattler, & Bruno, 2019). Prospective students find it challenging to evaluate the level of education and living conditions in the host country prior to enrolling in the school because international education is a pure service. For instance, the nation's reputation becomes a crucial cue when making decisions. The country-of-origin impact in the evaluation of foreign products is frequently explained by the country's image. It is often used for stereotyping that affects one's evaluation of the country, its people, and its products.

Institution Image (II)

The most significant factors influencing students' decision of higher education institution are institutional characteristics linked to university reputation and image. (Hemsley-Brown & Oplatka, 2015). Higher education institutions use brands as a tool to identify, differentiate, and position their company, much like businesses do. A brand is made up of both tangible and intangible components. Some examples of tangible components are the name, logo, symbol, and product, while intangible components include brand personality, societal values, and brand identity. (Kladou, Kavaratzis, Rigopoulou, & Salonika, 2017).

Student's intention to study

Understanding consumer purpose may aid marketers in anticipating consumer behavior with regard to marketing and the capacity of the business to keep customers. (Scheinbaum, 2012). Consumer purpose describes how someone intends to act going forward. Whether or not to engage in the behavior within a specific time period will rely on his or her motivation. (Blackwell, DSouza, Taghian, Miniard, & Engel, 2006). Consumer intent is broken down into the following categories: consumption intent, shopping intent, spending intent, and transaction intent. Purchase behavior is expected to positively correlate with purchase purpose. (Armitage & Conner, 2001).

Research Gap and Novelty

By examining the relationship between self-identities, country image, and institution image in the context of a comparison study of higher education between students in the cities of Seoul and Jakarta, this study aims to examine the phenomenon of the intention of Indonesia students majoring in business management to choose a study destination.

The intention to choose a study destination can be understood by looking at its cognitive, aspects that are normative and emotional. Numerous earlier studies, like Kemp, Madden, and Simpson (1998), concentrate on students' cognitive assessments of the costs and benefits of each study location and make use of economic theories of choice. Push-pull theory, which is used by Ahmad and Buchanan (2017), Boycott, Rodriguez González, Bustillo Mesanza, and Mariel (2011), Wilkins, Balakrishnan, and Huisman (2012), and Zheng (2014), describes how institutional factors and economics in the host and home countries interact. Few researchers are attempting to explain the purpose and choice of the international student to select a study location using psychological theories like the theory of planned behavior. Goel, De Jong, and Schnusenberg (2010); Li, Liu, and Rojas-Méndez (2013); and Schnusenberg, De Jong, and Goel (2012) are a few of them.

International higher education is a risky product because prospective students cannot completely evaluate it before purchasing, claim Basha, Sweeney, and Soutar (2016). Students from developing nations who must pay high costs to learn and live in the host country are also at increased risk. (Bamber, 2014; Foster, 2014).

Intention to study is influenced by outcome expectancy, or expected benefits from studying abroad (Ayenagbo, Kimatu, & Rongcheng, 2011; Bamber, 2014), perceived image of the host country (Basha et al., 2016); Cheng, Mahmood, & Yeap, 2013); perceived institutional image (Ahmad & Buchanan, 2017); Fang & Wang, 2014; Jon et al., 2014; Wilkins (Arar & Haj-Yehia, 2013; Shu & Scott, 2014). Based on the foregoing justification, the list of prior studies on the intention to choose study destination is summarized below.

The majority of studies either concentrate on the cognitive and normative aspects or ignore the emotional components, such as national self-identity. (Cleveland & Laroche, 2016, Conner, Reardon, Miller, Salciuviene, & Auruskeviciene, 2017). Additionally, research on the impact of affective elements produced conflicting results. (Jin et al., 2015, Zeugner-Roth et al., 2015). Additionally, prior study frequently overemphasized students' institution preferences and underemphasized the significance of the image of the host nation. (Cubillo, Sanchez, & Cervino, 2006; Hemsley-Brown & Oplatka, 2015). The impact of self-identity on an institution's image has only been studied for tangible goods, not for the provision of educational services. (Seo, Buchanan-Oliver, & Cruz, 2015). Additionally, research on the relationship between self-identity and intention behavior are scarce and recent. (Cleveland et al., 2016). Therefore, the goal of this study is to examine the relationship between self-identity and behavioral purpose, using institutional and national image as mediators. With regard to prior studies on self-identity, country image, institution image, and desire to choose a study location, this study aims to fill in knowledge gaps. It was discovered that very few studies have used country and institution image as a mediator, making this research novel. Additionally, since there are few comparison studies of foreign study destinations (Hemsley-Brown & Oplatka, 2015), this research also aims to investigate the variables that influence Korean students majoring in business management in Seoul to choose Indonesia as their country of study.

Figure 1 Research Framework

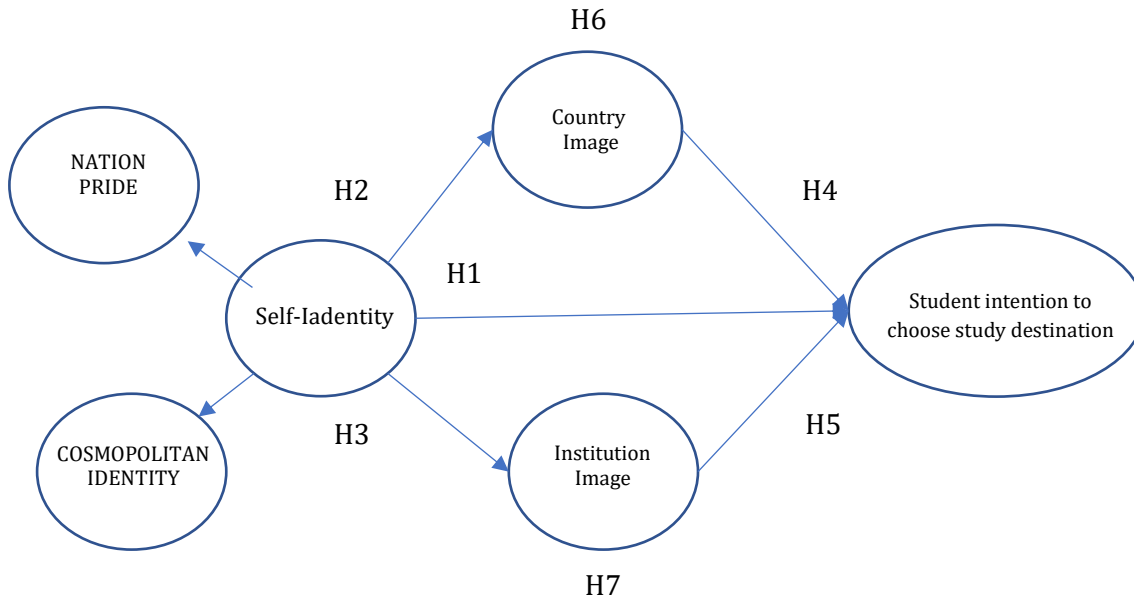

Source: Author (2021)

H1: Self-identity has a positive effect on the Intention to choose a study destination

H2: Self-identity has a positive effect on a Country's Image.

H3: Self-identity has a positive effect on Institution's Image

H4: Country Image has a positive effect on the intention to choose a study destination

H5: Institution Image has a positive effect on the Intention to choose a study destination

H6: Country Image mediated the relationship between Self-identity and Intention to choose a study destination

H7: Institution Image mediated the relationship between Self-identity and Intention to choose a study destination.

2. RESEARCH METHOD

Types and sources of DATA

Primary data and secondary data are the two types of information and data used in this research. Primary data is a type of research information that is gathered directly from the source (rather than through middlemen) in order to address specific research questions. Primary data for this research were taken directly from questionnaires that respondents had completed. While looking for and gathering materials from businesses, books, reports, brochures, and other previously collected data, secondary data is the source of research data. (Table 2).

Table 2 Type of data

Type of Data	Description	Source
Primary Data	Responses to questionnaires	Registered Agent of FPG Indonesia
Secondary Data	Materials by searching and collecting	Previous research, books, reports, and feedback from the academic supervisor

Source: Data processed by the author (2021)

POPULATION & SAMPLE

It was determined that the sample size needed for this study is a minimum of 50 students for each location (Jakarta and Seoul) based on the Cohen Table and G Power analysis. The unit analysis is individual because the purpose of this research is to examine how socio-identities, country perceptions, and institution perceptions affect students' intentions to study abroad. It means that each person's data is collected, and their response is then regarded as a separate data source. (Sekaran & Bougie, 2009)

Figure 2 G Power Analysis

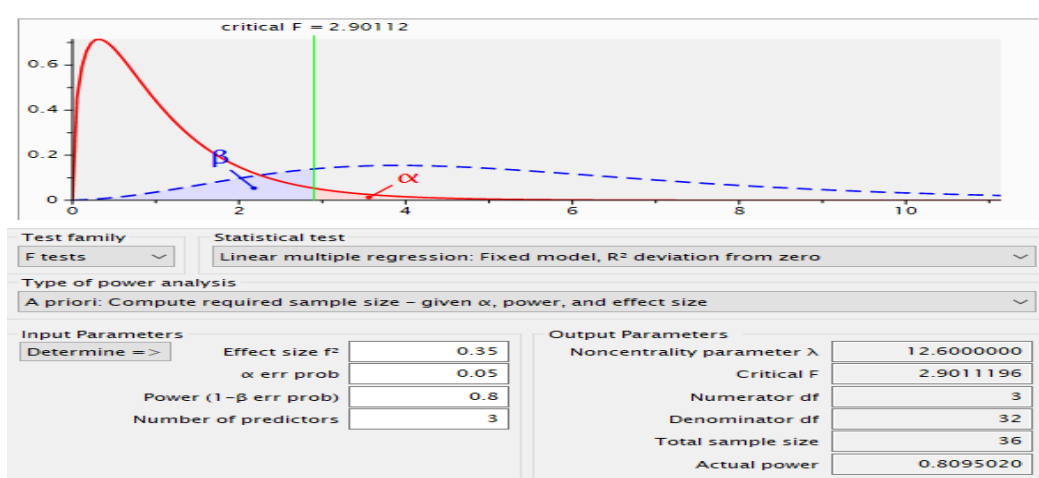

Source: Data processed by G Power software (2022)

3. RESULT AND DISCUSSION

Measurement model evaluation

Based on student survey results from Seoul, South Korea, the research model in Figure 3 was created. To determine whether the model satisfies the standards of a good model, it should be assessed in two different methods. In the first, an assessment model is used, and in the second, a structural model is evaluated. To assess the measurement model, a set of requirements for proving construct validity and

reliability must be satisfied. Internal consistency reliability can be attained using both Cronbach's alpha tests and composite reliability. (Hair et al., 2014; Wilden et al., 2013).

Figure 3 Research Model 1 (South Korean Respondent)

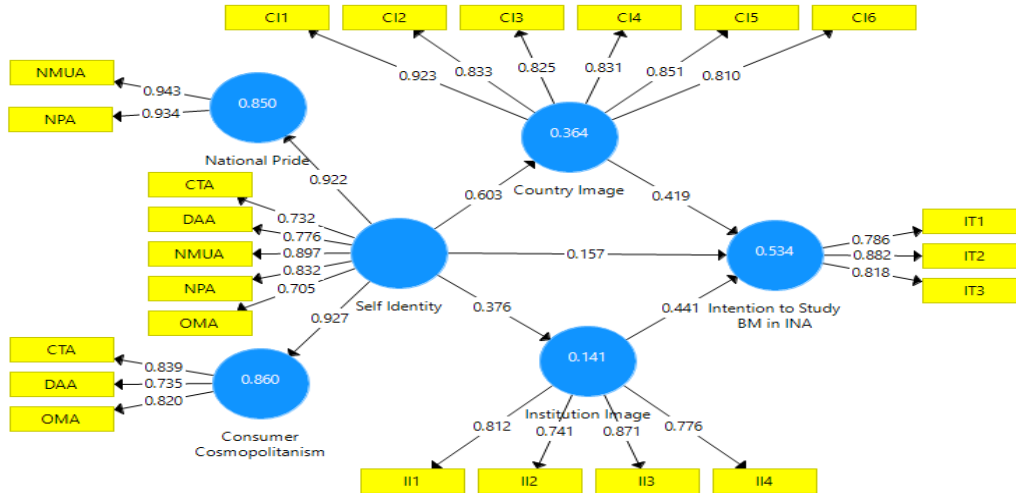

Source: PLS-SEM Report, 2022

The outer loading is the primary criterion used to assess the study model. As can be seen in Figure 4, every outer loading value that is greater than 0.7 indicates that the item's estimated relationships to the construct to which it was allocated are valid. Are they regarded as extremely satisfactory? (Henseler, Ringle, & Sinkovics, 2009). Research model 1 has met the evaluation standards as a result.

Figure 4 Research Model 2 (Indonesian Respondent)

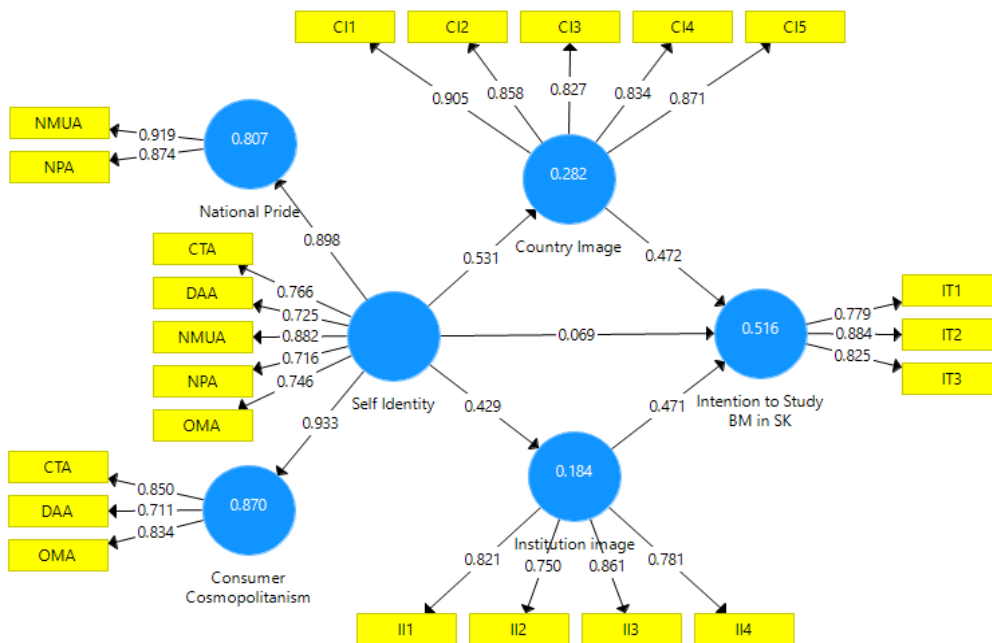

Source: PLS-SEM Report, 2022

Hypothesis Test

The bootstrapping method was used to assess the hypothesis because it reveals the significance of path coefficients by generating empirical t values greater than the critical value. (t distribution values). The statistic is regarded as significant at a predetermined margin of error (0.05). 5000 is the suggested bootstrap sample size by Hair et al. (2014). Using the bootstrapping method in SmartPLS3, the significance and t values of the route coefficients were calculated. The p-value is 0.05 (at 5%) and the t-value is 1.65 when only one tail is used. (Hair et al., 2014). Table 2.1 provides a summary of the results.

Table 4.1 Hypothesis testing result of Model 1

	Path	Original Sample	T Statistics	P Values	support
H 1	Self-Identity → Intention to Study in Jakarta	0.157	0.882	0.378	Not supported
H 2	Self-Identity → Country Image	0.603	7.181	0.000	supported
H 3	Self-Identity → Institution Image	0.376	3.268	0.001	supported
H 4	Country Image → Intention to Study in INA	0.419	2.409	0.016	supported
H 5	Institution Image → Intention to Study in INA	0.441	3.175	0.002	supported
H 6	Self-identity -> Country Image -> Intention to Study in INA	0.252	2.110	0.035	supported
H 7	Self-identity -> Institution image -> Intention to Study in INA	0.166	2.650	0.008	supported

Source: PLS-SEM Report 2022

The impact of self-identity on intention to study abroad is weak (0.157), as shown in Table 4.1, with a t-value of 0.885 (1.65) and a p-value of (0.378) higher than 0.05 (at = 5%). Joseph F. Hair Jr. et al. (2016) found that the effect is small and not significant, suggesting that Self-Identity does not positively influence the intention to study in Jakarta and that the effect is not statistically significant. As a result, hypothesis one is not supported.

The same method was used to evaluate the hypothesis about respondents' intentions to study in South Korea for Research Model 2, which includes respondents from Jakarta. Table 4.2 provides an overview of the Model 2 hypothesis testing findings.

Table 4.2 Hypothesis testing result of Model 2

	Path	Original Sample	T Statistics	P Values	SUPPORT
H1	Self-Identity → Intention to Study in SK	0.069	0.393	0.694	Not supported
H2	Self-Identity → Country Image	0.531	4.835	0.000	supported
H3	Self-Identity → Institution Image	0.429	3.843	0.000	supported
H4	Country Image → Intention to Study in SK	0.472	2.901	0.004	supported
H5	Institution Image → Intention to Study in SK	0.471	3.401	0.001	supported
H6	Self-identity → Country Image → Intention to Study in SK	0.251	2.184	0.029	supported
H7	Self-identity → Institution image → Intention to Study in SK	0.472	2.901	0.004	supported

Source: PLS-SEM Report 2022

Table 4.2 demonstrates that the direct relationship between self-identity and desire to study abroad (South Korea) is weak (0.069), with a t-value of 1.65 and a p-value greater than 0.05 (at = 5%). Joseph F. Hair Jr. et al. (2016) found that the effect is small and not statistically significant; as a result, H1 is not supported, showing that Self-Identity does not positively affect the intention to study in SK. On the other hand, the path coefficient (0.531), t-value, p-value, and (0.000) indicate that H2 is supported because the impact of Self-identity (SI) on Country Image (CI) is strong. The third hypothesis, which examines the impact of self-identity (SI) on institutional image, will be evaluated next. (SI). The outcome demonstrated that the impact is strong, as indicated by the path coefficient (0.429), with a t-value (3.843) and p-value. (0.000). This implies that H3 is supported because there is enough evidence to accept it.

4. CONCLUSION AND RECOMMENDATION

Summary of theoretical implications. Managerial implications. Limitation and Future research recommendation.

The first research objective is to examine the clear relationship between Self-identity (SI) and the intention to study abroad. (IT). According to the findings, neither model 1 with South Korean students

as respondents nor model 2 with Indonesian students as respondents backed H1. This indicates that Self-identity has a very slight and negligible direct impact on the intention to study abroad.

Using the respondent's two distinct countries, South Korea and Indonesia, this study's second goal is to evaluate the effect of self-identity (SI) on country image for both models 1 and 2. According to the findings, Country Image is positively impacted by SI for both Models 1 and 2.

The third study objective is to investigate the relationship between Self-identity (SI) and Institution Image (II) for Models 1 and 2, respectively, using data from South Korean students and Indonesian students. The results demonstrate that for both model 1 and model 2, SI has a favorable and substantial impact on II.

The impact of a country's image on the intention to study abroad is the subject of the fourth research goal. The outcome indicates that Country Image (CI) has a significant positive impact on the intention to study abroad, and both model 1 using data from South Korean students and model 2 using data from Indonesian students support the hypothesis (H4).

Determine the impact of institution image on the decision to study abroad is the fifth research goal. (IT). The outcome shows that H5 was supported, indicating that II has a favorable impact on the intention to study abroad for both research model 1 using data from South Korean students and research model 2 using data from Indonesian students.

The sixth research goal is to determine if Country Image mediates the relationship between the secondary effects of Self-identity and Intention to Study Abroad. The findings suggest that Country Image mediates the relationship between study models 1 and 2, which use data from students in South Korea and Indonesia, respectively. Self-identity does not have a direct impact on the intention to study in SK/INA; however, the indirect impact is made positive and meaningful by the variable country image.

The seventh research goal is to determine if Institution Image mediates the relationship between the secondary effects of Self-identity and Intention to Study Abroad. The findings suggest that Institution Image has a mediating impact for both research models 1 and 2, which use data from students in Indonesia and South Korea, respectively. Although self-identity does not have a direct impact on the intention to study in SK/INA, it does have a positive and substantial indirect impact through the variable institution image.

The eighth research goal is to find out if students from Indonesia and South Korea have distinct mean values for their intentions to study abroad. Students from South Korea are more likely to want to go to Indonesia to study. The outcome shows that H8 was supported, which indicates that more South Korean students intend to study in Indonesia than do Indonesian students intend to study in South Korea, and that this disparity between the two groups of students is sizable.

The research has some restrictions. The data collection is the first constraint. The sample was given by the respondent, who lives in both Jakarta and Seoul. The study's conclusions can only be extrapolated to the region around Jakarta and Seoul as a consequence. The data's short collection period, from May to July 2021, may suggest that the intention to study varies depending on the timeframe, which brings us to the second disadvantage. Demographic information, like the kind of institution, makes up the third restriction. Private national schools predominate; little is known about public and international schools, whose enrollment is still insignificant in contrast to private national schools.

REFERENCES

- Abdullah, D., Jayaraman, K., Shariff, D. N., Bahari, K. A., & Nor, N. M. (2017). The effects of perceived interactivity, perceived ease of use and perceived usefulness on online hotel booking intention: A conceptual framework. *International Academic Research Journal of Social Science*, 3(1), 16-23.
- Abdullah, F., Ward, R., & Ahmed, E. (2016). Investigating the influence of the most commonly used external variables of TAM on students' Perceived Ease of Use (PEOU) and Perceived Usefulness (PU) of e-portfolios. *Computers in human behavior*, 63, 75-90.
- Ajzen I 1991. The theory of planned behavior. *Organizational Behavior and Human Decision Processes*, 50: 179-211
- Al-Azawei, A., & Lundqvist, K. (2015). Learner differences in perceived satisfaction of an online learning: An extension to the technology acceptance model in an Arabic sample. *Electronic Journal of E-Learning*, 13(5), pp412-430.
- Aliman, N. K., & Mohamad, W. (2013). Perceptions of service quality and behavioral intentions: A mediation effect of patient satisfaction in the private health care in Malaysia. *International Journal of Marketing Studies*, 5(4), p15.
- Al-Sharafi, M. A., Arshah, R. A., Herzallah, F. A., & Alajmi, Q. (2017). The effect of perceived ease of use and usefulness on customers' intention to use online banking services: the mediating role of perceived trust. *International Journal of Innovative Computing*, 7(1).
- Antasari, K. C., & Yaniartha, D. 'yan. (2015). Pengaruh Efektivitas Sistem Informasi Akuntansi Dan Penggunaan Teknologi Informasi Pada Kinerja Individual Dengan Kepuasan Kerja Sebagai Variabel Pemoderasi. *Jurnal Akuntansi Universitas Udayana*, 102, 2302–8556.
- Arora, A. (2003). E-Insurance Analysis of the impact and implications of e-commerce on the insurance industry. *Unpublished Dissertation, Cass Business School, London*.
- Awa, H. O., Eze, S. C., Urieto, J. E., & Inyang, B. J. (2011). Upper echelon theory (UET) a major determinant of information technology (IT) adoption by SMEs in Nigeria. *Journal of Systems and Information Technology*, Vol. 13, pp. 144–162.
- Baecker, O., Ackermann, L., Ackermann, W., & Fleisch, E. (2010). Mobile claims management: smartphone Application in motor insurance. *I. VW Management-Information*, 2010(4), 13-18.
- Barnes, J. 2003. *Secrets of Customer Relationship Management*. Yogyakarta: Penerbit Andi.
- Caffaro, F., Cremasco, M. M., Roccato, M., & Cavallo, E. (2020). Drivers of farmers' intention to adopt technological innovations in Italy: The role of information sources, perceived usefulness, and perceived ease of use. *Journal of Rural Studies*, 76, 264-271.
- Chen, L., & Aklikokou, A. K. (2020). Determinants of e-government adoption: testing the mediating effects of perceived usefulness and perceived ease of use. *International Journal of Public Administration*, 43(10), 850-865.
- Cheung, C. M., M. K. Lee, and D. R. Thadani. 2009. The impact of positive electronic word-of-mouth on consumer online purchasing decision, pp. 501–10. Berlin: Springer. doi: 10.1007/978-3-642-04754-1_51
- Christina Whidya Utami, 2015, *Manajemen Ritel : Strategi dan Implementasi Operasional Bisnis Ritel Modern di Indonesia*, Salemba Empat, Jakarta
- Cigdem, H., & Ozturk, M. (2016). Factors affecting students' behavioral intention to use LMS at a Turkish post-secondary vocational school. *International Review of Research in Open and Distributed Learning*, 17(3), 276-295.
- Davis, F. D. (1986). A technology acceptance model for empirically testing new end-user information systems. *Cambridge, MA*.
- Davis, F. D. (1989). Perceived Usefulness, Perceived Ease of Use and User Acceptance of Information Technology. *MIS Quarterly*, 13(3), 319-340
- Davis, F. D., Bagozzi, R. P., & Warshaw, P. R. (1989). User acceptance of computer technology: A comparison of two theoretical models. *Management Science*, 35(8), 982-1003.
- Davis, F. D., Bagozzi, R. P., & Warshaw, P. R. (1989). User acceptance of computer technology: A comparison of two theoretical models. *Management science*, 35(8), 982-1003.
- Defitri, S. Y., & Susanti, R. (2015). The Effect on the Ability of Individual Student Behavior Intention of Using the Internet as a Source of Literature with Perceived Ease of Use as an Intervening Variable.
- Dewi, I. G. A. A. O., Dewi, I. G. A. A. P., Kustina, K. T., & Prena, G. D. (2018). Culture of tri hita karana on ease of use perception and use of accounting information system. *International Journal of Social Sciences and Humanities*, 2(2), 77-86.
- Damien Hallegatte., & Jacques Nantel. (2006) *The Intertwined Effect of Perceived Usefulness, Perceived Ease of Use and Trust in a website on the Intention to Return*.
- Fendini, D. S., Kertahadi, & Riyadi. (2014). Pengaruh kualitas sistem dan kualitas informasi terhadap kepuasan pengguna (Survei Pada Karyawan Pengguna Aplikasi Pelayanan Pelanggan Terpusat (AP2T) di PT. PLN (Persero) Area Malang). *Jurnal Penelitian Fakultas Ilmu Administrasi Universitas Brawijaya Malang*, 1–11. <https://doi.org/10.1017/CBO9781107415324.004>

- Ferdinand, A. (2006). *Structural Equation Modelling dalam Penelitian Manajemen*. Edisi 4. Semarang: Badan Penerbit Universitas Diponegoro
- Ferdinand, A. (2014). *Metode Penelitian Manajemen edisi kelima*. *Badan Penerbit Universitas Diponegoro, Semarang*.
- Fishbein, M., & Ajzen, I. (1975). *Belief, Attitude, Intention and Behavior: An Introduction to Theory and Research*. Reading, MA: Addison-Wesley Publishing Company
- Fishbein, M., Jaccard, J., Davidson, A. R., Ajzen, I., & Loken, B. (1980). Predicting and understanding family planning behaviors. In *Understanding attitudes and predicting social behavior*. Prentice Hall.
- Floh, A., M. Koller, and A. Zauner. 2013. Taking a deeper look at online reviews: The asymmetric effect of valence intensity on shopping behaviour. *Journal of Marketing Management* 29 (5-6):646–70. doi: 10.1080/0267257X.2013.776620
- Freierman, S. (2011, December 12). One million mobile Applications, and counting at a fast pace. *The New York Times*. Retrieved from http://www.nytimes.com/2011/12/12/technology/onemillion-application-and-counting.html?_r=0
- Gibreel, O., D. A. AlOtaibi, and J. Altmann. 2018. Social commerce development in emerging markets. *Electronic Commerce Research and Applications* 27 (1):152–62. doi: 10.1016/j.elerap.2017.12.008.
- Google/IPSOS, & OTX MediaCT. (2011, April). *The mobile movement*. Think with Google. Retrieved from <http://www.thinkwithgoogle.com/insights/library/studies/the-mobilemovement/>
- Grimmelikhuijsen, S., Porumbescu, G., Hong, B., & Im, T. (2013). The effect of transparency on trust in government: A cross-national comparative experiment. *Public administration review*, 73(4), 575-586.
- Grover, P., Kar, A. K., Janssen, M., & Ilavarasan, P. V. (2019). Perceived usefulness, ease of use and user acceptance of blockchain technology for digital transactions—insights from user-generated content on Twitter. *Enterprise Information Systems*, 13(6), 771-800.
- Hair Jr, J. F., Sarstedt, M., Hopkins, L., & Kuppelwieser, V. G. (2014). Partial least squares structural equation modeling (PLS-SEM): An emerging tool in business research. *European business review*.
- Hajli, M. 2013. A research framework for social commerce adoption. *Information Management & Computer Security* 21 (3):144–54. doi: 10.1108/IMCS-04-2012-0024
- Hamid, A. A., Razak, F. Z. A., Bakar, A. A., & Abdullah, W. S. W. (2016). The effects of perceived usefulness and perceived ease of use on continuance intention to use e-government. *Procedia Economics and Finance*, 35, 644-649.
- Hellier P K, Geursen GM, Carr RA, Richard JA 2003. Customer re-purchase intention: A general structural equation model. *European Journal of Marketing*, 37(11): 1762-1800.
- Hilligoss, B., and S. Y. Rieh. 2008. Developing a unifying framework of credibility assessment: Construct, heuristics, and interaction in context. *Information Processing & Management* 44 (4):1467–84. doi: 10.1016/j.ipm.2007.10.001.
- Holbrook, B. (2011, January 28). 5 ways to make money with iphone Application. AppCraver. Retrieved February 19, 2012, from <http://www.appcraver.com/make-money-with-iphoneApplication/>
- Hong, J. C., Tai, K. H., Hwang, M. Y., Kuo, Y. C., & Chen, J. S. (2017). Internet cognitive failure relevant to users' satisfaction with content and interface design to reflect continuance intention to use a government e-learning system. *Computers in Human Behavior*, 66, 353-362.
- Huang, J. H., Lin, Y. R., & Chuang, S. T. (2007). Elucidating user behavior of mobile learning. *The electronic library*.
- Hulland, J., Chow, Y. H., & Lam, S. (1996). Use of causal models in marketing research: A review. *International journal of research in marketing*, 13(2), 181-197.
- Hussain, A., Mkpojiogu, E. O., & Yusof, M. M. (2016, August). Perceived usefulness, perceived ease of use, and perceived enjoyment as drivers for the user acceptance of interactive mobile maps. In *AIP Conference Proceedings* (Vol. 1761, No. 1, p. 020051). AIP Publishing LLC.
- Iberia, M. and Iivari, J. (1995) 'The effects of self-efficacy on computer usage', *Omega*, Vol. 23, No. 6, pp.587–605.
- Indarsin, T., & Ali, H. (2017). Attitude toward Using m-commerce: The analysis of perceived usefulness perceived ease of use, and perceived trust: A case study in Ikens Wholesale Trade, Jakarta–Indonesia. *Saudi Journal of Business and Management Studies*, 2(11), 995-1007.
- Iqbal, M. K., Amer, S., Raza, A., Mushtaq, H., & Faraz, N. A. (2018). An Empirical Study on the Effect of Perceived Usefulness and Ease of Use on Purchase Intention Through Mobile Devices in Pakistan: A Mediating Role of Online Trust. *Europe Journal of Business and Management*, 10.
- Januarsyah, R. (2015). The Influence of Perceived Ease of Use, Perceived Usefulness, and Attitude Toward Behavior on the Intention to Use of Internet Banking (Case Study at Bni 46 Bank Kln Brawijaya University Malang). *Jurnal Administrasi Bisnis*, 27(1).
- Joo, Y. J., Park, S., & Lim, E. (2018). Factors influencing preservice teachers' intention to use technology: TPACK, teacher self-efficacy, and technology acceptance model. *Journal of Educational Technology & Society*, 21(3), 48-59.
- Joo, Y. J., Park, S., & Shin, E. K. (2017). Students' expectation, satisfaction, and continuance intention to use digital textbooks. *Computers in Human Behavior*, 69, 83-90.

- Joo, Y. J., So, H. J., & Kim, N. H. (2018). Examination of relationships among students' self-determination, technology acceptance, satisfaction, and continuance intention to use K-MOOCs. *Computers & Education*, 122, 260-272.
- Kabir, M. A., Saidin, S., & Ahmi, A. (2017). A conceptual framework on the influence of perceived usefulness, perceived ease use and computer self-efficacy on the intention to use electronic collection system in Nigerian federal hospitals. *International Journal of Management Research and Reviews*, 7(3), 259.
- Kaouther, B. (2016). An analysis of business' acceptance of internet banking: an integration of e-trust to the TAM. *Journal of Business & Industrial Marketing* ISSN: 0885-8624 Article publication date: 3 October 2016
- Keith, D. R., Hart, C. L., McNeil, M. P., Silver, R., & Goodwin, R. D. (2015). Frequent marijuana use, binge drinking and mental health problems among undergraduates. *The American Journal on Addictions*, 24(6), 499-506.
- Kim, S., and H. Park. 2013. Effects of various characteristics of social commerce (s-commerce) on consumers' trust and trust performance. *International Journal of Information Management* 33 (2):318–32. doi: 10.1016/j.ijinfomgt.2012.11.006.
- Koukopoulos, Z., Koutromanos, G., Koukopoulos, D., & Gialamas, V. (2020). Factors influencing student and in-service teachers' satisfaction and intention to use a user-participatory cultural heritage platform. *Journal of Computers in Education*, 1-39.
- Koukopoulos, Z., Koutromanos, G., Koukopoulos, D., & Gialamas, V. (2020). Factors influencing student and in-service teachers' satisfaction and intention to use a user-participatory cultural heritage platform. *Journal of Computers in Education*, 1-39.



CHAPTER 2

Higher Instruction Human Resources Management (HRM) Hones and Information Administration Specialist Presence

Adi Muhajirin

Postgraduate Doctoral Student Universitas Bhayangkara Jakarta Raya
adi.muhajirin@dsn.ubharajaya.ac.id
0000-0003-4732-6115

Sumaryono

Postgraduate Doctoral Student Universitas Bhayangkara Jakarta Raya
202230152017@mhs.ubharajaya.ac.id
0009-0004-2938-2353

Dewi Puspaningtyas Faeni

Lecturer of Postgraduate Doctorate
Universitas Bhayangkara Jakarta Raya, Indonesia
dewi.puspaningtyas@dsn.ubharajaya.ac.id
0000-0002-1911-4425

ABSTRACT

Information administration has an affect on human asset hones, agreeing to the organizational life cycle hypothesis. By comparing colleges that incorporate information administration in their scholastic educational programs to those that don't , we trust to decide the impact of information administration on the astuteness of Human Asset (HR) hones. Discoveries show that colleges that instruct information administration are way better prepared than those that don't development investigate, instruction, and data absorption through human asset hones. Besides, colleges that did not instruct information administration tend to be considerably more centered on operational issues and troubles in creating the aptitudes and information of their HR work force, and their execution is essentially lower. Research limitations and implications - collecting respondents through purposive sampling has its limitations. It is suggested to increase the number of respondents by broadening the study's geographical scope and extending its duration. Originality/importance - Numerous organizations and universities have conducted extensive research on human resource practices. However, courses in knowledge management that emphasize lecturers as knowledge management agents are still uncommon. This study also incorporates the life cycle theory by examining HR practices in higher education and encouraging institutions to prioritize strategic HR issues in their environment.

Keywords: Knowledge Management, University, Organizational Life Cycle

INTRODUCTION

Competition from within and outside the country for Higher Education services, as well as meeting consumer demands (consumer-driven). Numerous educational institutions have been compelled to improve the quality of instruction. Administrators in higher education have done everything possible to continue implementing changes within their organizations in order to survive in the current competitive environment. Knowledge management is vital to the success of universities in order to achieve this objective (Faeni, 2022).

Universities have abandoned the traditional paradigm of resource-based competitiveness in favour of knowledge-based competition as a result of shifting consumer demand (such as from students). It emphasizes making the most of their knowledge and technology. The phenomenon has made Knowledge Management a crucial strategy for achieving and maintaining a company's competitive advantage (Rastogi & Senge, 2000).

This concept of organizational transformation has become a cornerstone of management and other fields. Individual labour and vocation, as well as the formation and expansion of groups, have shifted as a result of the knowledge strategy utilized in this transformation. The result is organizational innovation, expansion, and reorganization of resource use. Management experts have borrowed numerous concepts, analogies, and theories from other fields, ranging from organizational development to evolutionary biology, in order to fathom how organizational change can be cultivated (Andrew et al., 1995).

In academic activities, ongoing educational practices influence the university's HR policies and practices to a certain extent. In this regard, the concentration will be on the human resource practices of university professors who teach knowledge management courses or other courses incorporating knowledge management. This paper will therefore consider KM lecturers as agents of knowledge management in conveying tacit knowledge to their students and other academics. On the other hand, we consider how agents of knowledge management can serve as informants to report and evaluate the HR practices of an organization (Faeni, 2016).

Implementing knowledge management in a university setting has been crucial, specifically in terms of how particular agents can construct knowledge management. Nonetheless, empirical research on the implementation of knowledge management agents in higher education is still required (Anantatmula, 2010; Shoham & Perry, 2009). According to a small number of studies conducted in Western nations, higher education institutions can convert their activities from knowledge institutions to learning institutions through knowledge management. Universities that have adopted knowledge management have positioned themselves as a response to competition and efficiency challenges in the education system.

Learning how HR practices in higher education institutions and knowledge management can improve organizational performance and competitive advantage is fascinating. To accomplish this objective, this paper will describe the implementation of knowledge management in universities and the ways in which these practices can vary between each observed institution. Knowledge creation in an

organization requires a process and the enabling factors of knowledge management; it cannot occur instantly. (Suharti, 2009) Knowledge Management is a must-implement concept that requires additional research and development. Universities in Indonesia face numerous obstacles and restraints in developing education practices such as curriculum, educational facilities, teaching and learning, teacher quality, and profession, which all hinder the efficient implementation of knowledge management.

In addition, as discussed in the lecture course, many higher education institutions continue to operate solely on the basis of their respective traditions and the implementation of knowledge management activities within organizations. This research is crucial because it explains how university knowledge management practices can be improved. Using the organizational life cycle (OLC) theory (McEvoy & Buller, 2013), it is known that every organization has fluctuating human resource (HR) issues and requires dynamic solutions as it encounters new competition environments and expands. Numerous OLC models explain how universities go through distinct phases in terms of characteristics such as age, size of staff or student body, and leadership regeneration (Rutherford et al., 2003).

According to Rutherford et al. (2001), organizations that are able to grow larger and healthier will have increasingly formal, complex, and sophisticated human resource practices. It implied that universities transitioning from their start-up phase to their mature phase would have more sophisticated human resources, invest in a more advanced HR system, and be more formal. Dibrell et al. (2011) also demonstrated that universities would configure and modify their HR practices to meet business needs and competitive advantage as they progress through the organizational life cycle stages.

This paper aims to determine the role of the lecturer as a knowledge management agent. To enhance organizational performance and competitive advantage, university HR practices are governed by knowledge management. The purpose of this paper is to examine the implementation of knowledge management in universities and how these practices can vary from institution to institution. In addition, the paper will examine the staff's comprehension of knowledge management and how knowledge management lecturers inspired various academic activities that contributed to the competitive advantage of their universities.

LITERATURE REVIEW

Davenport and Prusak (1998) describe Knowledge Management. They differentiate the knowledge management process into an understanding of data, information, and knowledge, as well as how these three concepts can be used to generate new benefits between implementations. Knowledge is not merely data or information; it also relates to usability and how people perceive the difference between theory and practice.

The majority of organizations do not investigate members' possible concealed knowledge. Similarly, Delphi Group research demonstrates how organizational knowledge can be structurally preserved in universities (Estriyanto, 2008): 1. 42% in the psyche (thinking) of their staff; 2. 26% of paper records; 3. 20% of digital documents; 4. 12% of the electronic knowledge base.

42% of all knowledge is retained in the brain, according to research. This form of knowledge is referred to as implicit knowledge, which is conceptualized as concealed knowledge. The investigated knowledge is comprised of paper documents (26%), electronic documents (20%), and electronic items based on knowledge (12%). To make potential tacit knowledge explicit and transferable to others, further investigation must be conducted.

Knowledge Management Agent

The agent is the subject of numerous definitions and discussions. Self-reliant, mobile, and sentient agents are possible. (Burnell, et al., 2008) An agent is typically a program or set of programs that live (continue) to multiple destinations (based on objectives) in a dynamic environment (changing access to resources) and can decide to take action in order to achieve the goal. The agent has a unique role of cooperation, negotiation, and communication with other divisions or groups in order to complete diverse tasks in their field, such as the discovery and classification of new knowledge, the search and retrieval of information, and the automatic evolution of domain ontology.

Agents can intervene in the context of knowledge management beyond adaptation to a specific environment. They may assist other users with a variety of tasks, or they may be delegated specific tasks by other users. They can reduce work and information overload (intelligent information agents, personal assistants), search for and direct the user to diverse knowledge (filtering agent), and enhance the learning process (pedagogical agent, story-telling agent) (Klusch, 2002; Brna, Cooper, & Razmerita, 2001).

Organizational Life Cycle

There are numerous universities in Indonesia that teach business management courses, but knowledge management frequently lacks standardization and documentation. Each organization operates in accordance with the traditions of its leaders, and the application of knowledge management to the organization's activities is rarely discussed in the literature. Consequently, this study is appealing because it depicts how knowledge management activities are implemented in the universities observed.

According to the organizational life cycle (OLC) theory (McEvoy & Buller, 2013), every health organization is in a constant state of development and competition. For the university context, the OLC models can be used to explain how organizational health can be measured based on university characteristics such as age, employee size, or student population, as well as leadership regeneration (Rutherford et al., 2003). In addition, OLC theory can be used to explain how universities teaching knowledge management courses face HR challenges (the lecturer of the course is the knowledge management agent) and how the rate of organizational growth is primarily measured by the increase or decrease in the number of faculty staffs and student population.

To observe the university life cycle, McEvoy and Buller (2013) proposed using the number of employees and business volume (i.e. the number of students) as achievement criteria for developing the organization's systems and procedures.

Rutherford et al. (2001) also demonstrated that organizations that are able to grow larger and healthier have HR practices that are more formalized, intricate, and sophisticated. This means that universities

with a mature level of growth will have more complex human resources responsibilities and will invest in more sophisticated HR systems and more formalized academic activities. According to Dibrell et al. (2011), the organizational life cycle stages are followed by an adjustment and reconfiguration of HR practices to meet business demand and competitive advantage. Thus, it can be assumed that the early phases of a university will be characterized by unstructured and informal human resources (HR) operations, which will likely be led by the institution's founder. By adhering to OLC theory, the early phases of a university may concentrate their HR practice on HR administration-related issues, but they must be more adaptable in how they practice knowledge management.

As the university grows, there is a need for new employees and new skills, which frequently exceeds the founder's capacity to manage the institution, which is more complex than a university in its early stages. It will initiate the formalization of the HR department in order to enhance their evaluation and achieve greater efficiency. In the affirmative phase, the HR function becomes more modernized and incorporated with the business strategy in order to generate a greater competitive advantage.

Several empirical studies documenting HR practices and OLC stages (Pearson et al., 2006) have provided empirical support that the differences in HR practices are attributable to the various sizes and stages of the organizational life cycle, i.e., the differences in the formalization of employee selection, performance appraisal, reward employment, and benefits.

Moreover, the owner's or founder's policies can influence the extent and formality of universities' HR practices. According to McEvoy and Buller (2013), a larger university will necessitate the employment of HR specialists and the utilization of professional recruitment resources.

Therefore, we will assume that universities offering courses in knowledge management will have sophisticated recruitment procedures, qualified on-the-job training, performance evaluation methods, formalized HR procedures, and HR record keeping.

In addition, McEvoy and Buller (2013) discovered that HR practices would vary based on the scale of the organization. It encourages us to determine how differences in perception of knowledge management agents will affect HR practices in universities. We then compare this university to those that lack a knowledge management agent. OLC theory also predicts that these distinctions can be observed by comparing the quality of HR practices, such as recruitment practice, selection, training, assessment systems, compensation design, the role of HR staff, HR orientation level, HR outsourcing, and information systems that shape university staff performance. Therefore, in systematized organizations, HR has the authority to regulate them, invest time, and cultivate their contribution to organizational success.

Institutional Size

To define the role of the knowledge management agent in altering HR practices, we postulate that HR practices tend to diverge as universities advance through their life cycle. Moreover, it will observe the role of knowledge management agents as exemplified by their lecturer who teaches knowledge management or management courses as required learning.

As universities grow, it is intriguing to learn how knowledge management agents partake in academic activities and extend the concept of knowledge management into human resource management practices. The second concern is how universities with observed HR procedures can function without a knowledge management agent.

According to Hornsby and Karatko (1990), the number of employees reveals the extent of an organization's development. This indicates that the organization must have between 150 and 250 employees. In addition, according to the definition of Higher Education (Directorate of Higher Education of Indonesia, 2013), a university is poised for development if it has been operating for at least five years and has graduated at least one cohort of students. In terms of the majority of the student body, universities that have graduated 100 students are deemed to have entered the growth phase (Faeni, 2015).

We conclude, based on the OLC theory, that policies and practices in higher education will vary depending on the size of the institution, as it is unclear how universities can integrate knowledge management into their HR practices and have more formal and sophisticated HR practices than universities that do not offer knowledge management courses.

EXAMPLES AND PROCEDURES

Twenty-five universities were represented for the purposes of this study by faculty or university administrators acting as respondents on their behalf. In addition, for the purpose of simplification, six universities with knowledge management agents and six universities without knowledge management agents were collected until a total of 12 universities were gathered and divided into two categories. The first cohort was comprised of universities with knowledge management agents that had between 800 and 1200 faculty members and over 15,000 students. The second group consisted of universities without knowledge management agents with 100 to 300 faculty and staff and fewer than 8,000 students.

In addition, secondary data from the syllabi and curricula of universities that teach knowledge management or sub-courses containing knowledge management have been incorporated into this study. The curriculum and syllabus were obtained from the universities' respective websites.

Next, a face-to-face verification is conducted to confirm the legality of the number of students and faculty, followed by the distribution of a questionnaire from the start of July 2014 to the end of August 2014. After obtaining permission from the leaders of each university and assuring them that respondent data will be kept confidential and anonymous, we invite respondents to take part in an online survey regarding HR practices at each university.

The questions are divided into ten categories: number of employees and lecturers, technology integration and strategic initiatives, customer focus and quality improvement, HR learning and practice, international research participation, time spent on core tasks, provision of HR services and administration, use of technology for file management, participation in strategy formulation, competent HR staff, HR performance evaluation, and HR expectations fulfilment gap.

Using the OLC theory as a guide, we wish to determine if the presence of a knowledge management agent can improve university resource utilization. How will HR strategies and practices in universities with a knowledge management agent be superior to those without? This is the second query. This distinction can be deduced based on the formalization of HR practices and file management priorities.

EVALUATION AND RESULTS

Gradually, we inquire about the time HR personnel utilize in the workplace. This is accomplished by observing HR roles such as file management and assembling or meeting. The participants were then asked to recall the percentage of similar activities in prior years. Table I presents the results of the HR function and their time utilization.

For universities with a knowledge management agent, time spent on essential work, HR services, and administration is more valuable. We found that both teams acknowledged operating in a disciplined manner to manage HR and administrative files.

Table 1. The t-test was used to compare the following average differences:

Employees size	Universities with the knowledge management agent		University without knowledge of management agent		T-Value	P(Two-Tailed)
	Mean	SD	Mean	SD		
	8.28	41.183	3.90	19.416	2.018	0.05
Technology integration	8.34	41.477	4.12	20.495	2.018	0.05
Initiatives and strategies, customer orientation and quality improvement Research and practical HR management	8.00	39.804	4.34	21.581	2.017	0.05
International research	8.28	41.181	4.18	20.792	2.018	0.05
Use of time for core work, provision	8.32	41.378	4.26	21.186	2.019	0.05

Contemporary Exploration of Social Sciences in the Post Pandemic Era - 1

of staff services and administration						
Using technology to manage files	8.28	41.183	4.02	20.003	2.018	0.05
Participation in strategy formulation	8.16	40.591	4.16	20.694	2.018	0.05
Competent staff	7.94	39.507	4.24	21.088	2.018	0.05
HR performance appraisal	8.20	40.789	4.16	20.692	2.018	0.05
Failure to meet expectations	8.22	40.886	4.61	22.961	2.018	0.05

Source: processed data (2014)

The t-value analysis indicates that universities with knowledge management agents have more employees, faculty, and students than those without. This is evident when comparing the mean value of universities with and without a knowledge management agent (3,90).

The recognition that their university has technology integration to manage HR practices and educational practices through e-HR and E-Learning is another indication that universities with knowledge management agents will be distinct from those without. This is supported by Ulrich et al. (2008), who state that a mature organization will alter its focus and expand to access local, national, and international markets. In addition to advanced leadership, innovative product development, and synchronized strategic thinking, a mature organization's human resource practices also demonstrate advanced management. According to the survey, universities with knowledge management agents have a greater number of initiatives and strategies, a stronger customer focus, and improved HR learning and practices. Seven of the twelve universities in our sample reported participation in international research activities, whereas the other five did not respond. Overall, these indicators suggest that universities requiring a knowledge management agent in our samples were less involved in international research participation. This has been confirmed by a two-stage survey of university administrators, who acknowledged that they rarely conduct international research. Five universities acknowledged this statement because they believe they lack a knowledge management agent to concentrate their efforts on knowledge development. They must determine how to encourage innovation and creativity among the university personnel in their research endeavours.

In addition, universities lacking agents for knowledge management are less engaged in organizational development and struggle to forge new strategic alliances. Universities with a knowledge management

agent are more likely to have incorporated technology to manage file maintenance usage time (8.34 per cent versus 4.12 per cent) than universities without a knowledge management agent. This indicates that the first party was assigned a mission that could not be accomplished manually. It is evident, after informing the relevant university administrators, that HR technology can free up their time to resolve other issues arising from the increased activity of strategic business partnerships. Six universities acknowledge that the presence of a knowledge management agent will enhance the quality of their work, particularly in regard to knowledge-related tasks.

According to Table I, universities with knowledge management agents and universities without agents spent a comparable amount of time cultivating strategic business partners. In addition, the third segment of the questionnaire inquired about strategic partnerships, eliciting responses from four universities that play no role and eight universities that have implemented knowledge management. When provided with a list of ten strategic activities, such as "identify and determine the design of a new strategy" or "assessing employment strategy and education strategy," four universities with a knowledge management agent ranked recruitment and development of staff talent and identifying ways to build public-university trust as the most frequent strategic activities. The findings indicate that universities lacking a knowledge management agent tend to be less active in formulating strategies than universities with such an agent.

We also investigate each organization's HR function priorities (HR planning, compensation and benefits, training, evaluation, recruitment, and selection). The significance of recruitment and HR planning has increased in both categories. Comparable to McEvoy and Buller (2013) in this situation. Human resources at universities with a knowledge management agent appear to have made greater advances in establishing a strategic business role than those without a knowledge management agent.

Universities with a knowledge management agent have greater HR and business practice technology implementation and integration by 49 per cent than universities without a knowledge management agent. In terms of HR practices and HR efficacy, the first group consistently rates higher. Moreover, universities with knowledge management agents recognized the importance of having qualified HR personnel and academic collaborators. Universities with a knowledge management agent have proficient human resources departments because they recognize the importance of staff quality.

Table I displays the variance of response patterns from both groups regarding their human resources skills in the "dynamics of the organization" (interpersonal skills, coaching, etc.) as well as their satisfaction with their human resources capacity in metrics, IT, and data analysis and data mining. Additionally, there are considerable distinctions between two of the five skill types: business partner and metric skills. In addition, the table below examines the extent to which HR personnel are equipped to flourish in their work environment. Again, their response is substantially greater than universities without a knowledge management agent.

This can be explained by the size and human resource personnel of the organization. It is suggested that HR personnel at universities without a knowledge management agent execute the dual function of HR generalists rather than specialists as employees' companions and university leaders. Instead, the university with agent knowledge management will have HR personnel who are more likely to be

specialists and will carry out their HR duties with greater precision. Moreover, universities with a knowledge management agent (3,703) are better suited to deal with HR issues than those without (1,835). This also demonstrated that universities employing knowledge management agents are better equipped to handle their HR-related workload and have stronger personal relationships with their HR counterparts.

To determine the source of the perception gap, we compute the gap for each dimension as the difference between the perception and the perception of the required performance. Universities with a knowledge management agent rated their HR performance as superior, on average, to universities without a knowledge management agent. For example, the first group's HR performance dimensions have a mean value of 4.04, whereas the second group's HR performance dimensions have a mean value of 2.002. The HR performance of the first group was rated higher for HR services and business strategy but lower for cooperation roles. Moreover, the first group (universities with knowledge management agents) typically has a smaller disparity and greater capacity to meet expectations than the second group. This is consistent with the findings of Lawler et al. (2006), who discovered that high performance is related to greater employee satisfaction, superior human resource skills, and increased HR staff knowledge.

Our findings filled a lacuna in regards to establishing a viable working relationship for developing HR excellence and the combination of the two to produce superior HR services. This demonstrates that universities without a knowledge management agent may encounter operational challenges due to an obsolete HR strategy. In addition, it demonstrated that a knowledge management agent could remedy the organization's inability to manage business partners, business strategy, and HR analysis. Respondents in both categories rated their performance in the second dimension as the lowest. In addition, the findings indicated a need for a greater emphasis on strategic business issues in universities with knowledge management agents.

CONCLUSION AND DISCUSSION

The analysis demonstrates that the organization's life cycle comprises distinct phases. In an academic setting, knowledge management has a positive impact on the effectiveness of human resource practices. According to the organizational life cycle theory (Greiner, 1972), universities that have entered the mature growth stage are characterized by sophisticated human resource practices and the capacity to establish a strategic role with other business partners in the local, national, and international communities.

Overall, universities with knowledge management agents can concentrate their HR management resources on resolving current business strategy issues and attaining greater empowerment and enhanced HR management, as evidenced by systematized routines and file management. These results are consistent with McEvoy and Buller's (2013) conclusion that OLC in organizations with knowledge management experts tends to manage more resources and have more formal HR practices than institutions without knowledge management specialists. In addition, the university appears to be significantly more content with the skills and knowledge of its HR personnel and assigns a higher

rating to the performance dimensions of these employees. According to our analysis, the university that implemented knowledge management practice is better able to manage its HR responsibilities and has a superior strategy for evaluating its employees' skills.

In addition, they are characterized by greater use of human resource resources and a greater need for training, indicating that routine activities have evolved into complex tasks involving students and faculty. This indicates that the agent is able to balance knowledge management and more difficult tasks through intensive training. In actuality, the knowledge management agents have enhanced the HR capacity of the organization to address the challenges posed by a sudden increase in caseload and modify it to generate satisfactory job performance.

This investigation is limited to the geographically segmented and segmented city of Jakarta. It must be generalized to other locations or universities in Jakarta and Indonesia.

REFERENCES

- Absah, Y. (2008). Pembelajaran Organisasi: Strategi Membangun Kekuatan Perguruan Tinggi. *Jurnal Manajemen Bisnis*, 1(1): 33-41
- Anantatmula, V & Kanungo, S. (2010). Modelling Enabling Factors for Effective KM Implementation. *Knowledge Management Journal*, 14 (1): 100–113
- Andrew (1995). Organizational Development and Change Explanation. 510-512 *Academy of Management Review*
- Brna, P., Cooper, B., & Razmerita, L. (2001). Marching to the incorrect drum: Pedagogical agents, emotion, and student modelling. *Workshop Proceedings on Attitude, Personality, and Emotions in User-Adapted Interaction in*
- Burnell, E. (2008). *Knowledge Management System Development and Maintenance for Dynamic and Complex Domains*. p.583. IGI Global.
- Conjunction with User Modelling. City of Sonthofen, Germany
- Davenport, T. H., & L. Prusak. (1998). *Working Knowledge: The Management of Organizational Knowledge*. Harvard Business School Press, Boston.
- Dibrell, C., Craig, J. & Hansen, E. (2011). An organizational life cycle perspective on the natural environment, market orientation, and firm innovativeness. *Journal of Small Business Management*, Volume, Vol. 49 No. 3, pp. 467-489
- Estriyanto (2008). Implementasi Knowledge Management pada APTEKINDO, Pembentukan Sharing Culture antar Pendidikan Teknologi dan Kejuruan di Indonesia. *Konvensi Nasional IV APTEKINDO*, 3-6 Juni 2008
- Faeni, D. (2015). Information and Knowledge Management HRM Practices and Existence of Knowledge Management Agent in Higher Education. 5(3), 47–54. www.iiste.org
- Faeni, Dewi Puspaningtyas. (2015). HRM Practices and Existence of Knowledge Management Agent in Higher Education, *Information and Knowledge Management*, 5(3) 2224-5758. <https://www.iiste.org/Journals/index.php/IKM/article/view/20581>
- Faeni, Dewi Puspaningtyas., Ratih Puspitaningtyas Faeni, (2016) Cognitive Style and Composition of Employees in Shaping Intellective Sales Team. *Business Economig Social Science Humanities Conference (BESSH)*. Volume 11. September 2016.. Willey Publisher.
- Faeni, Dewi Puspaningtyas., Ratih Puspitaningtyas Faeni, (2016) Manager Characteristics, HR Renewal, Marketing Strategies, Partnership Motivation, Work Orientation, Work Standardization, on SMES Business Resilience in the Competition: Insurance Healthcare Services. *Scholedge International Journal of Management & Development* Volume 3, Issue 2. Pages 32-48 Publisher. Scholedge the Scholarly Publishing
- Faeni, Dewi Puspaningtyas., Ratih Puspitaningtyas, (2020) The Role Of Management Control System On Firm Performance. *Talent Development & Excellence*, 12(1), 1629-1639. <http://www.iratde.com/>
- Faeni, Dewi Puspaningtyas., Ratih Puspitaningtyas, Yuliansyah Yuliansyah. (2022). The COVID-19 Pandemic Impact on the Global Tourism Industry SMEs: A Human Capital Development Perspective. *Review of International Business and Strategy*, 32(4), 2059-6014. <https://doi.org/10.1108/RIBS-08-2021-0116>
- Faeni, Dewi Puspaningtyas., Yudi Nugroho. (2017) The Role Of Women Entrepreneurs Leadrships, Social Capitaland Absorptive Capacity Through Skills Upgrading Concept In Small To Medium Enterprises In Jakarta, Indonesia. *International Journal of Pure and Applied Mathematics*, 116(24), 511-520. <http://www.ijpam.eu/>

- Greiner, L.E. (1972). As organizations expand, evolution and revolution are inevitable. *Harvard Business Review*, Vol. 50 No. 4, pp. 37-56
- J.S. and Karatko, D.F. (1990). Human resource management in modest businesses: crucial questions for the 1990s. *Journal of Small Business Management*, Volume, Vol. 28 No. 3, pp. 9-18
- Lawler, E.E. III, Boudreau, J.W. S.A. Mohrman & Co. (2006). *A Review of Human Resource Organizations for Achieving Strategic Excellence*. Stanford Business Books, located in Stanford, California.
- McEvoy & Buller (2013). Human resource management in medium-sized businesses. *The American Journal of Business*, Vol. 28 No. 1, pp. 86-105
- Pearson, T.R., D.Y. Stringer, and L.H. Mills. Summers, D.F., and Summers, D.F. (2006). Micro versus small businesses: a comparison of human resource personnel, practices, and support. *Journal of Management Research*, Volume, Vol. 6 No. 2, pp. 102–112.
- Rastogi, P.N. (2000). The Virtuous Reality of Competitiveness Is Knowledge Management and Intellectual Capital. *Human Systems Management*, 19: 39-48
- Rowley, J. (2000). How prepared is Higher Education for Knowledge Management? *The International Educational Management Journal*. Vol. 14, No.7. 325-333
- Rutherford, M.W., and P.F. Buller. McMullen, P.R., and McMullen, P.R. (2003). Problems with small to medium sized businesses' human resource management throughout their existence. *Management of Human Resources*, Vol. 42 No. 4, pp. 321–335.
- Rutherford, M.W., P.R. McMullen. and Oswald, S. (2001). A self-organizing map approach to examining the issue of the small business scale. The volume number of the *Journal of Business & Economic Studies*. 7. No. 2, pp. 64-79
- S. Shoham & M. Perry. (2009). Knowledge Management is a Mechanism for Technological and Organizational Change Management in Israeli universities. *57(2) Journal of Higher Education*: 201-218
- Senge, P.M. 2000. The Academy as a Community of Learners: Contradiction or Realistic Future? A.F. Lucas and colleagues. *Essential Roles for Department Chairs in Leading Academic Change*: 275-300
- Suharti, et al. 2009. Identifikasi Kesiapan Penerapan Knowledge Management di Perguruan Tinggi (Studi terhadap Faktor Pemberdaya (Enablers) Knowledge Management). *Jurnal Ekonomi dan Bisnis* Vol. XV No.2: 181-196
- Sycara, K., Widoff, S., Klusch, M., & Lu, J. (2002). The dynamic pairing of heterogeneous software agents in cyberspace; *LARKS. Autonomous agents and multiagent systems*, vol. 5, pp. 173–203.
- Ulrich, D., Younger, J. along with Brockbank, W. (2008). HR departments of the twenty-first century. *The Journal of Human Resource Management*, Volume, 47, pp. 829-850.



CHAPTER 3

The Effect of Word of Mouth And Online Reviews on Consumer Trust : (Case Study in Erigo)

Shinta Amelia Putri

Student of the Faculty Of Economics And Business
Bhayangkara Jakarta Raya University, Indonesia
pshintaamelia@gmail.com

Muhammad Choirudin

Student of the Faculty Of Economics And Business
Bhayangkara Jakarta Raya University, Indonesia
Muhammadchoirudin29@gmail.com

Naufal Yudha Irwanto

Student of the Faculty Of Economics And Business
Bhayangkara Jakarta Raya University, Indonesia
naufalyudha50@gmail.com

ABSTRACT

This study aims to analyze the effect of Word of Mouth (WOM) and online reviews on consumer trust in products. This research uses qualitative methods sourced from online books and journals such as Google Scholar, Google Books, and others. The results of the study show that WOM and online reviews have a significant positive effect on consumer confidence. In addition, factors such as the credibility of information sources, the suitability of information sources with consumer needs, the suitability of messages with consumer experiences, the quality and quantity of information, positive or negative sentiment, information consistency, and the level of consumer involvement also influence consumer trust in WOM and online reviews. . The results of this study can provide information and insight for companies and marketers in designing effective marketing strategies by utilizing WOM and online reviews to increase consumer confidence in products. developing a hypothesis that combines variables through many factors is the research objective that underlies the making of this article. considering the literature review: 1) word of mouth 2) online review 3) Brand Trust.

Keywords: Word of Mouth, Online Review, Brand Trust

INRODUCTION

Erigo is a fashion product that develops original fashion brands Indonesia which emphasizes high quality and supportive product design all travel and daily needs. Erigo must currently rank among the best, most dependable, and high-quality apparel brands available in Indonesia. Stand on November 20, 2010 under the brand "Selected and Co" which later changed to be Erico. Erigo targets traveling needs with a unique design comfortable and suitable for consumers. In 2015, Erigo achieved turnover twenty billion rupiah.

Marketing strategy, branding, and promotions are heavily employed in the process of generating Erigo's turnover with the goal of attracting consumer attention. The "Wandering Souls" are another product offered by Erigo. This expression of the brand's essence strives to inspire and motivate the younger generation to always have a strong sense of curiosity and enthusiasm for exploration. This ad celebrates many cultures, personalities, and ideas and is meant to inspire the local young generation, especially in the fashion industry, to think critically and creatively.

Erigo invites the younger generation to go through every step a dynamic life journey with courage, equipped with an open mind, and of course a style that suits each unique personality.

To fulfill these aspirations, Erigo provides a variety of products comfortable, affordable and flexible clothing options. Erigo which is local brand from Indonesia, has several closest competitors in the competition in the fashion industry, one of them is Lea Jeans, which has 34 outlets spread throughout Indonesia with 200 Department stores, Billionaires Project, and I Love Indonesia. Some of these Erigo competitors are enough famous in the fashion industry, where each brand moves with almost the same target market, namely young people or millennials.

Figure 1. advertisement in Time Square, New York, USA.



Erigo managed to get the opportunity as a local brand representing Indonesia to do a fashion show at New York Fashion Week (NYFW) 2022 on September 9, 2021.



In today's digital era, the influence of "Word of Mouth" and "Online Reviews" is increasingly important in consumer purchasing decisions. An important role of "Word of Mouth" is that consumers tend to seek information about products or services from the recommendations of people they trust, such as family, friends, or other people they know. Whereas "Online Reviews" are information written by other consumers on websites, forums or other platforms that discuss certain products or services.

In this context, the brand or brands are very important in efforts to win business competition and build high consumer trust. If consumers have high trust in a brand, they tend to choose products or services from that brand even though the price is higher than competing brands.

Therefore, it is important to understand how "Word of Mouth" and "Online Reviews" influence consumers' perceptions and purchasing decisions towards certain brands. Research examining the effect of these factors on consumer trust in certain brands can provide valuable insights for brand owners in building and maintaining their brand reputation.

In this context, this study will examine the effect of "Word of Mouth" and "Online Reviews" on consumer trust in the Erigo brand. Erigo is a brand chosen as the object of research because it has uniqueness and characteristics that allow it to analyze its effect on consumer trust. This research is expected to contribute to the development of marketing and branding science and assist brand owners in making strategic decisions to win business competition and build high consumer trust.

Formulation of the problem

In accordance with the background context that has been discussed previously, there are several problem formulations that need attention, namely:

1. How do WOM and Online Reviews influence a consumer's trust in Erigo products?
2. What are the factors that influence Erigo's consumer trust in WOM and Online Review?

Research purposes

1. To find out how WOM and Online Reviews influence a consumer's trust in Erigo products.
2. To find out the factors that influence Erigo's consumer trust in WOM and Online Review.

LITERATUR REVIEW

Word of Mouth

WOM stands for "Word of Mouth", which literally means "word of mouth". This term is used in a marketing context to describe the process by which consumers talk about products or recommend products to others through their social interactions, such as personal conversations, social media, or online reviews. WOM is considered as one of the most effective marketing strategies because it can influence consumer perceptions and purchasing decisions without significant cost to the company. Consumers tend to trust recommendations from friends, family or other people they trust more than

advertisements or promotions from the company itself. Therefore, WOM can be an invaluable tool in building a strong brand image and increasing consumer loyalty.

Word of Mouth Marketing is communication about products between people who are considered independent from the company (Henri, 2018). Which provides the product. These communications are conducted in a medium that will be deemed independent of company. This communication can be conversational, or just one-way testimonials. For example talking directly, by telephone, e-mail, listgroup, or other means of communication (Silverman, 2001). Word-of-mouth (WOM) or word-of-mouth communication is a communication method that involves recommending a good or service to people or groups, either directly or indirectly, with the goal of obtaining personal information, according to Kotler & Keller (2012).

Online Consumer Reviews

This also holds true for evaluations written by tourists who are familiar with and have been to popular tourist spots or who are merely familiar with the locations' facts but have never visited them, which may lead to opinions or presumptions that may sway others. Based on the description provided above, it can be inferred that electronic word of mouth refers to a statement that provides an evaluation of a good or service offered by customers who have used those goods or services online. Because it might affect consumer purchasing decisions, e-WOM is especially crucial.

Consumers' distinct preferences, levels of product or service expertise, and terms of usage are all reflected in their reviews, which can be utilized as consumer information by other consumers who wish to purchase or use the product or service. Consumer reviews can hurt a firm, even though it may urge it to publish pertinent product information or photographs. Online customer reviews have a flaw when they come from people who know one another; the information presented is erroneous, claim Bakos in Auliya, et al. (2017). The resulting information is more accurate if it is different and originates from sources that are not acquainted.

The indications in online consumer reviews are explained as follows, per Lackermair et al. (2013: 2) :

- 1) Recognizing Consumer knowledge of the use of internet reviews as a judgment or point of view when selecting a product to purchase.
- 2) The frequency of reviews is used as a source of customer data.
- 3) Evaluation Consumers should compare reviews with other consumers' opinions in their best interests.
- 4) Internet Securities reviews are taken into account.

Consumer's Trust

Consumer trust is a consumer's belief or positive attitude towards the quality, reliability and integrity of a product or brand. This includes consumer confidence in the information and promises provided by the company or brand. Consumer trust is an important factor in purchasing decisions because consumers will be more inclined to buy products from brands they trust than brands they do not trust. Consumer trust can be influenced by various factors, including personal experience with a brand or

product, information obtained from word of mouth or online reviews, brand image, brand credibility, and other factors that influence consumer perceptions. Maintaining and increasing consumer trust is the main goal of a successful marketing and brand management strategy.

Table 1. Relevant previous research results

No	(Author, Year)	Previous Research	Article Similarity	Article Differences
1	(Karundeng et al., 2023)	The influence of price and customer reviews on the purchasing decision of Erigo brand fashion products on shopee marketplace on GMIM sion Malalayang youth.	Customer review partially has a positive effect significant to the purchase decision.	Prices with indicators of price affordability, price compatibility with product quality, competitiveness Price, price suitability with benefits based on the results of the study partially have a positive effect significantly to the Purchase Decision of Fashion Brand Erigo products in the Shopee Marketplace for Youth Gmim Zion Malalayang.
2	(Hariningsih et al., 2022)	Gender Differences in Perceived Prices, Promotions, and Online Reviews Erigo Clothing Products on Online Purchase Intentions	There is no similarity because online reviews have no significant effect	The results of the analysis found the influence of price and promotion perception variables on online purchase intentions. While online reviews were found to have no effect on online purchase intentions. Meanwhile, after testing moderation, only the relationship

Contemporary Exploration of Social Sciences in the Post Pandemic Era - 1

				between perceptions price and purchase intention significantly moderated by gender.
3	(Walyoto et al., 2022)	The Influence of Social Media Sharia Marketing, Product Quality, Prices, and Reviews Online Customers Against Erigo Product Purchase Decisions	Reviews online customers have a positive effect and significantly to the purchase decision on Erigo consumers.	Social media promotion variables, quality product, price has a positive effect on purchasing Erigo products
4	(V.A.R.Barao et al., 2022)	The influence of digital marketing, word of mouth, and service quality on purchasing decisions for Erigo brand products in Surabaya	The results of the Word of Mouth research have a significant effect on Buying decision.	There are other variables such as digital marketing and service quality that can affect purchasing decisions.
5	(Agustina et al., 2023)	Influence of brand ambassador, e-wom, and brand trust on the purchase decision of Erigo products.	The results of the study show that Brand Trust has a positive and significant effect on buying decision.	Meanwhile, ewom has a negative and significant effect on purchasing decisions

RESEARCH METHODS

This contribution to the field was made using a qualitative research methodology and literature review. Meneliti pengaruh faktor sebagian besar. Journals and online publications like Mendeley, Google



Scholar, and other media online serve as central repository for bibliographic information. The single most useful academic skill is literature analysis of the current topic. Without regard to academic discipline, this study must be recognized as the first important step in effective research or brainstorming. The purpose of literary analysis is to provide guidance or recommendations for appropriate analytical work.

DISCUSSION

Using a literature review and qualitative approaches, this scientific contribution was developed. Look into how different elements interact with one another. A source for bibliographical research include journals and online publications like Google Scholar, Mendeley, and other online media. Doing literature searches on a particular subject is one beneficial academic experience. This research should be viewed as a crucial first step in successful research or development, regardless of the discipline. A literature review's purpose is to provide as a foundation or frame of reference for pertinent research projects.

The influence of Word of Mouth and Online Reviews on a consumer's trust in Erigo products

Consumers' faith in Erigo products can be significantly impacted by verbal and online reviews. Due to the fact that this information originates from sources that consumers believe to be reliable, WOM can have a significant impact. Consumer confidence in the Erigo product might also be impacted by online reviews. A person's firsthand experience with the Erigo product is detailed in the review. Online reviews provide consumers with a wealth of important information, including the benefits and drawbacks of Erigo items as well as user impressions.

Factors influencing Erigo consumer trust in WOM and Online Reviews

Consumer trust in WOM and online reviews can be impacted by a number of factors, including:

1. **Credibility of Information Sources:** People are more likely to trust information from people they know and trust, such as friends and family, subject-matter experts, or reliable online sources.
2. **Aligning Information Sources with Consumer Needs:** Consumers will place more trust in information sources that meet their requirements, such as accounts of comparable situations from other people.
3. **Message Conformity to Consumer Experience:** Consumers are more likely to believe communications or facts that are consistent with their own experiences. They might not trust it if the message or information does not match their personal experience.
4. **Information Quality and Quantity:** Customers will have more faith in internet evaluations and word-of-mouth recommendations that include pertinent, thorough information. Consumer confidence may also be impacted by the amount of information offered.
5. **Positive or Negative Sentiment:** Customers are more likely to believe WOM and online evaluations that are favorable or positive in their opinions of a good or service, and the opposite is also true.
6. **Information Consistency:** When word-of-mouth and internet reviews are congruent with other information consumers receive, they are more likely to believe them. Consumers could feel uncertain or lacking in confidence if there are discrepancies in the information.

7. Consumer Engagement Level: Customers who are very involved with a product or service are more likely to pay attention to word-of-mouth recommendations and internet reviews and to put greater faith in these sources of information.

Conceptual Framework

After understanding the theoretical research and discussing the influence between variables, the following framework is produced:

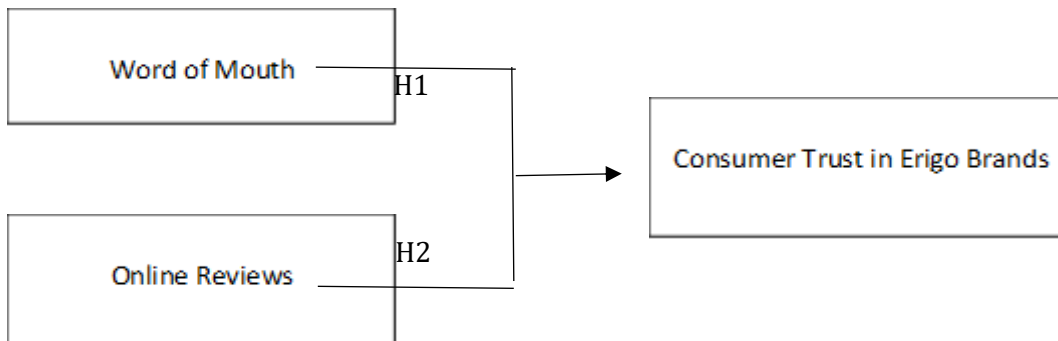

Figure 1 : Conceptual Framework

According to Figure, then: Word of mouth and online reviews have an effect on consumer trust in erigo brands. As for other variables that have an impact on consumer trust in erigo brands, they are:

1. Product Quality: (Loviga & Febriyanto, 2023) (Putra, 2021)
2. Brand Image and price: (Naufal & Kramadibrata, 2022) (Month & Sudrajat, 2019)
3. Celebrity Endorse & Brand Ambassador :(Ratna Sari et al., 2022) (Spry et al., 2011)

CONCLUSIONS AND RECOMMENDATIONS

Conclusions

Based on the discussion that has been described, several conclusions and suggestions can be put forward as follows:

1. Brand trust has a significant effect on the intention to buy Erigo products.
2. Electronic word of Mouth (e-WOM) has a significant effect on the intention to buy Erigo products
3. Brand trust and e-WOM has a positive and significant effect on the intention to buy Erigo products.

Recommendations

In order to increase customer trust, businesses must make local products their first choice rather than imports. However, higher prices do not necessarily indicate better quality. To increase eWOM, a company must monitor both positive and negative user reviews. Recommendations for future readers 1) There are a lot of respondents to get more accurate results. 2) Please be mindful of the pengamatan cakupan since the study's findings were compared to those of a Jakarta-based Erigo online channel.

REFERENCES

Agustina, R., Hinggo, H. T., & Zaki, H. (2023). *PENGARUH BRAND AMBASSADOR , E-WOM , DAN BRAND TRUST.*

2(1), 433–443.

Arli, D., & Tjiptono, F. (2014). The End of Religion? Examining the Role of Religiousness, Materialism, and Long-Term Orientation on Consumer Ethics in Indonesia. *Journal of Business Ethics*, 123(3), 385–400. <https://doi.org/10.1007/s10551-013-1846-4>

Bulan, S. I. S., & Sudrajat, R. H. (2019). Pengaruh Penggunaan Celebrity Endorser Arief Muhammad di Instagram Terhadap Brand Image Erigo Store. *Jurnal Sosial Politik*, 5(2), 322. <https://doi.org/10.22219/sospol.v5i2.8505>

Di, K., & Medan, K. (2022). 1, 2, 3. 199–211.

Fatimah, N. (2020). Pengaruh Media Sosial, Electronic Word of Mouth, Dan Citra Merek Terhadap Keputusan Pembelian Melalui Minat. *Molecules*, 2(1), 1–12. <http://klik.dva.gov.au/rehabilitation-library/1-introduction-rehabilitation%0Ahttp://www.scirp.org/journal/doi.aspx?DOI=10.4236/as.2017.81005%0Ahttp://www.scirp.org/journal/PaperDownload.aspx?DOI=10.4236/as.2012.34066%0Ahttp://dx.doi.org/10.1016/j.pbi.201>

Hariningsih, E., Setiawan, R. N. B., Munarsih, E., & Rahman, M. T. (2022). Perbedaan Gender dalam Persepsi Harga, Promosi, dan Online Review Produk Pakaian Erigo terhadap Niat Pembelian Online. 20(1), 11–21.

Hariningsih, E., Setiawan, R. N. B., Munarsih, E., & Rahman, M. T. (2022). Perbedaan Gender dalam Persepsi Harga, Promosi, dan Online Review Produk Pakaian Erigo terhadap Niat Pembelian Online. 20(1), 11–21.

Henri. (2018). Pengaruh Dimensi Informasi Ewom Dan Penerimaan Informasi Terhadap Keinginan Untuk Mengirimkan Ulang Pesan. *Angewandte Chemie International Edition*, 6(11), 951–952., 1987, 11–30.

Jamilah, M., & Lutfie, H. (2020). Pengaruh Promosi Media Sosial Instagram Terhadap Keputusan Pembelian Produk Cv Sly E-Liquid. *E-Proceeding of Applied Science*, 6(2), 1334–1340.

Karundeng, E. F., Mandey, S. L., Lintong, D. C. A., Karundeng, E. F., Mandey, S. L., & Lintong, D. C. A. (2023). PRODUK FASHION BRAND ERIGO DI MARKETPLACE SHOPEE PADA PEMUDA GMIM SION MALALAYANG THE INFLUENCE OF PRICE AND CUSTOMER REVIEWS ON THE PURCHASING DECISION OF ERIGO BRAND FASHION PRODUCTS ON SHOPEE MARKETPLACE ON GMIM SION MALALAYANG YOUTH *Jurnal EMBA Vol . . 11(1)*, 873–884.

Kotler & Armstrong. (2002). *Perilaku Konsumen Dan Manajemen Pemasaran*. 1–476.

Karundeng, E. F., Mandey, S. L., Lintong, D. C. A., Karundeng, E. F., Mandey, S. L., & Lintong, D. C. A. (2023). PRODUK FASHION BRAND ERIGO DI MARKETPLACE SHOPEE PADA PEMUDA GMIM SION MALALAYANG THE INFLUENCE OF PRICE AND CUSTOMER REVIEWS ON THE PURCHASING DECISION OF ERIGO BRAND FASHION PRODUCTS ON SHOPEE MARKETPLACE ON GMIM SION MALALAYANG YOUTH *Jurnal EMBA Vol . . 11(1)*, 873–884.

Loviga, L. T., & Febriyantoro, M. T. (2023). Pengaruh Citra Merek, Harga, Dan Kualitas Produk Terhadap Pembelian Produk Erigo. *Bussman Journal: Indonesian Journal of Business and Management*, 3(1), 341–355.

Naufal, M., & Kramadibrata, B. S. (2022). Pengaruh Brand Image Dan Harga Terhadap Keputusan Pembelian Erigo Di E-Commerce Shopee Di Jakarta Barat. *Jisma*, 1(4), 695–700.

Prihatin, E., Ahmad, A., & Syahnur, M. H. (2023). Niat Beli Produk Kosmetik yang Dipengaruhi Promosi Media Sosial dan Electronic Word of Mouth (E-WoM). *Jesya (Jurnal Ekonomi Dan Ekonomi Syariah)*, 6(1), 1100–1110.

Putra, W. W. (2021). Pengaruh Persepsi Harga dan Electronic Word of Mouth Terhadap Keputusan Pembelian Online (studi pada konsumen erigo official shop shopee.co.id di kota malang).

Ratna Sari, Y., Harliyani, S., Sanjaya, V. F., Studi Manajemen Bisnis Syariah, P., & Islam Negeri Raden Intan Lampung, U. (2022). Pengaruh Harga, Brand Image, Dan Celebrity Endorser Enzy Storia Terhadap Minat Beli Produk Erigo. *Business and Entrepreneurship Journal (BEJ) e-ISSN*, 3(1), 2745–8547.

Putra, W. W. (2021). Pengaruh Persepsi Harga dan Electronic Word of Mouth Terhadap Keputusan Pembelian Online (studi pada konsumen erigo official shop shopee.co.id di kota malang).

Spry, A., Pappu, R., & Cornwell, T. B. (2011). Celebrity endorsement, brand credibility and brand equity. *European Journal of Marketing*, 45(6), 882–909. <https://doi.org/10.1108/03090561111119958>

Saputra, F., Khaira, N., & Saputra, R. (2023). Pengaruh User Interface dan Variasi Produk terhadap Minat Beli Konsumen (Studi Literature). *Jkis*, 1(1), 18–25. <https://dinastirev.org/>

T, H., Sani, A., Ardiansyah, M., & Wiliani, N. (2020). Online Shop as an interactive media information society based on search engine optimization (SEO). *International Journal of Computer Trends and Technology*,

V.A.R.Barao, R.C.Coata, J.A.Shibli, M.Bertolini, & J.G.S.Souza. (2022). No 主観的健康感を中心とした在宅高齢者における健康関連指標に関する共分散構造分析Title. *Braz Dent J.*, 33(1), 1–12.

Waluyo, S., Sujarwati, S., Manajemen, P., Syariah, B., Uin, F., Mas, R., & Surakarta, S. (2022). Pengaruh Pemasaran Syariah Media Sosial, Kualitas Produk, Harga, dan Review Pelanggan Online Terhadap Keputusan Pembelian Produk Erigo. *Jurnal Ilmiah Ekonomi Islam*, 8(02), 2210–2220. <http://dx.doi.org/10.29040/jiei.v8i2.5958>

CHAPTER 4

Intellectual Capital Determinants of Knowledge Sharing Through Organizational Capital of Village Officials in Sungai Penuh City

Ferry Siswadhi

Postgraduate Doctorate Student
University of Bhayangkara Jakarta Raya. Indonesia
202230152014@mhs.ubharajaya.ac.id
Orcid: 0000-0003-2311-3107

Mauledy Ahmad

Postgraduate Doctorate Student
University of Bhayangkara Jakarta Raya. Indonesia
202230152007@mhs.ubharajaya.ac.id
Orcid: 0000-0002-6377-63210

Dewi Puspaningtyas Faeni

Lecturer of Postgraduate Doctorate
University of Bhayangkara Jakarta Raya. Indonesia
dewi.puspaningtyas@dsn.ubharajaya.ac.id
Orcid: 0000-0002-1911-4425

ABSTRACT

Diversity, democratization, participation, community empowerment, and indigenous autonomy are central to the concept of village governance. The right development for the village is one that is accommodating to modernization but does not leave tradition as the root of life which is the identity or characteristic of the community. One of the main determinants in the success of these efforts is community participation in the overall village development process. The purpose of this research is to identify the factors that influence village officials in Sungai Penuh City to use their organizational capital to disseminate information. Intellectual capital can be broken down into three categories: human capital, social capital, and structural capital. Village chiefs from Sungai Penuh City's Kumun Debai subdistrict were the study's respondents. The method used is the full sampling method, so that the number of respondents is 153 people. Primary data, which is what was used for this study, was gathered by conducting in-depth interviews and distributing questionnaires to participants. The Structural Equation Model (SEM) was employed for this study's model testing procedures. Organizational capital in village apparatus in Kumun Debai District, Sungai Penuh City, was shown to be 91% affected by human capital, social capital, and structural capital. Knowledge sharing in rural infrastructure was affected by human, social, structural, and organizational factors to the tune of 5.6% in Sungai Penuh City's Kumun Debai District.

Keywords: Knowledge Sharing, Intellectual Capital, Organizational Capital, Stuctural Equation Model (SEM), Village Officials

INTRODUCTION

The Unitary State of the Republic of Indonesia is currently undergoing a period of development in which the government and people are working toward the realization of national ideals and goals, specifically the establishment of a just and prosperous society that is equitable materially and spiritually on the basis of Pancasila and the 1945 Constitution. Providing services, increasing participation, launching new initiatives, and empowering local communities are all under the purview of regional governments, which have the capacity to craft regional policies. In accordance with this idea, we also execute the principle of genuine and accountable independence. Thus, the utilization of Village Fund Allocation (ADD) is expected by the Government to increase community participation in rural development in a mutual cooperation (Achyani, 2019; Agustiningsih, 2020). The goal of rural development is to enhance the standard of living, knowledge, and initiative in these areas so that the full potential of the land and its people can be realized. Intellectual Capital is regarded as the most important factor in being successful in today's fast-paced business world. Because Intellectual Capital-based businesses draw scrutiny from many conflicting schools of economics and management thought. Furthermore, both static and dynamic approaches to Intellectual Capital have been established (Sari et al., 2019a) (Faeni, 2019).

Information, practical procedures, experience, intellectual property, and other forms of intangible assets that can be used to generate profits constitute an organization's Intellectual Capital (Chan et al., 2012). To boost a company's worth and competitiveness, it can make use of intangible assets known as intellectual capital (Agustami & Rahman, 2015). The whole total of an organization's stored information is known as its Intellectual Capital. Knowledge embodied in persons, in social relationships and networks, and in the processes, structures, and systems of an organization all contribute to its Intellectual Capital (Zhang et al., 2017).

Both small businesses and national economies can benefit greatly from investing in organizational capital. This is significant because it adds to the value of an organization's assets, which are said to be particularly valuable if they are difficult for rivals to copy and so give their owners a lasting edge in the marketplace. Machines, patents, brands, and human capital are all examples of tangible and intangible resources that can be put to productive use thanks to organizational capital (Liu et al., 2018). A number of authors argue that a company's organizational capital can, significantly, contribute to an increase in a company's productivity. In the 1980s, Prescott and Visscher coined the term "organizational capital" to describe the practice of amassing and utilizing employee records in order to boost operational efficacy (Sari, Yusnita, et al., 2022).

Embedded or institutionalized knowledge that can be preserved with the use of IT on an easily available and extendable database constitutes organizational capital. This may be the case with explicit information that has been documented in databases or in manuals and standard operating procedures, or it may be the case with tacit knowledge that has been captured, exchanged, and, if possible, codified. Human capital is the source of all value in an organization, but social capital is what makes those relationships possible (Sari et al., 2019b). Organizational capital, as defined by Evenson and Westphal, is the informational basis for the integration of human and physical resources into productive enterprises (Arumi et al., 2019).

LITERATURE REVIEW

Intellectual Capital

Information, practical skills, expertise, intellectual property, and other intangible assets are all examples of intellectual capital (Chan et al., 2012). Intellectual capital may be used by businesses to increase their profit competitiveness, and the factors that determine intellectual capital include their human, social, and structural capital (Zhang et al., 2017).

1. Human Capital

People's innate knowledge, acquired skills, and developed potential are all examples of human resources. Workers are able to accomplish their tasks and learn new things thanks to the information already stored in their brains. Workers that are well-versed in the industry and have a high level of expertise in their positions are better able to respond to shifts in consumer tastes and the state of the market. Employees that possess several skills and a wealth of experience are better able to create novel knowledge through the synthesis of existing bodies of knowledge, which in turn leads to novel goods and processes.

2. Social Capital

The term "social capital" is used to describe the wealth of real and potential information that can be tapped into through people's relationships with one another. It is a representation of the expertise that develops as a result of both formal and informal contacts among workers, and it serves as the foundation for internal processes of cooperation and knowledge exchange. An organization's psychological security, productivity, and efficiency can all benefit from greater social capital and less bias in the workplace. When employees work together frequently, they can learn from one another and grow in their ability to comprehend knowledge, access and obtain knowledge from fellow colleagues, make shared judgments regarding the application of knowledge, and collaborate on the production of new knowledge.

3. Structural Capital

Organizational processes, routines, and systems that rely on human expertise are said to have "structural capital." Structured methods or administrative routines for collecting, organizing, and applying different people's bits of knowledge. Methods and information that have been codified through extensive study and experience are examples of structural capital. The organization is able to enhance its expertise even if employees leave because of the way it documents and distributes prior successes and best practices in the form of SOPs, manuals, archives, and databases. As a result, the corporation can formalize its structural capital to enhance the efficacy of its decisions.

Organizational Capital

Gan & Saleh (2008) Organizational Capital is knowledge in organizations that is independent of people or in other words can be interpreted as knowledge that remains in the organization even though its workers leave the organization. Organizational success can be accomplished by establishing a firm and culture that encourages innovation and teamwork (Organizational Capital). Paying close attention to the sorts of competences that must continue to be maintained and developed within the organization

can improve growth connected to the ability to predict changes in the business environment, manage resources, and increase competitiveness (Prasetya et al., 2016).

Culture (informal and implicit knowledge), organizational structure (explicit and formal knowledge), and organizational learning (informal and explicit knowledge renewal processes) all contribute to what is known as a company's "organizational capital," which is the sum of all of the company's accumulated knowledge and how it is used to shape and develop the structure and activities of the organization (Martín-de-Castro et al., 2006).

Employees' ability to generate value for the business and its stakeholders is enabled by the sum total of a company's organizational capital (Yuli Ramanda, 2001). Because it involves the organization's internal processes, its efficiency is crucial to the organization's ability to create wealth through the integration of information and the sharing of talents. In addition, customer acquisition is aided by the knowledge management procedure.

In a theoretical approach, with the result that Organizational Capital is an asset and property of capital resources in the organization. This theory suggests that Organizational Capital cannot be imitated which makes this the value of each organization and company. Organizational capital cannot be fully codified or transferred to another company and copied by another company (Li et al., 2018).

Organizational capital is the ability that allows tangible and intangible resources, such as human capital, physical assets, and intellectual property, to be more productive (Juneja & Amar, 2018). Organizational Capital indicators (Martín-de-Castro et al., 2006):

1. Culture

Organizations with a strong culture are shown as examples of excellent management. From the inside, most businesses have a strong culture that encourages and rewards employees for their efforts. From the outside looking in, businesses that place a premium on customer satisfaction will be consistently accessible to their clientele, sharing relevant market data, engaging in collaborative product development, and inspiring passionate brand advocacy. To sum up, company culture is an important factor in the company's bottom line.

2. Structure

The structure of the organization is related to the competitive environment, which will be valuable if the characteristics of the organizational structure match the characteristics of the environment

3. Organizational learning

Organizational learning refers to the process through which a company or other group improves itself over time by accumulating and applying new information gained from experience. Within the company, the newly acquired information is shared.

Knowledge Sharing

To understand the notion of knowledge, at least the ability to distinguish between what is data and information. While there are many ways in which knowledge sharing benefits businesses, increased creativity stands out as particularly crucial (Amri et al., 2020). There has been a lot of work put into our knowledge resources. It is the opinion of many researchers and scholars that tacit knowledge

should be transformed into explicit knowledge in order to be properly considered and handled as a source of information (Yusnita et al., 2021). Sharing one's information, whether explicit or implicit, is referred to as knowledge sharing. He proposes three justifications for the spread of information :

1. The goal of any knowledge transfer is for the receiver to grasp the information and use it correctly.
2. Knowledge sharing is different from recommendation sharing in that the knowledge itself is shared rather than the recommendations.
3. Individuals, teams, departments, and entire companies can all benefit from and participate in knowledge exchange.

There are many factors that influence knowledge sharing behavior, namely the personal characteristics of knowledge carriers, as well as group and organizational characteristics tend to influence behavior towards knowledge sharing. It is obvious that sharing and transferring organizational knowledge and resources is one of the keys to organizational success (Sari et al., 2019b). Knowledge Sharing Indicators :

1. Organizational Culture

Organizational culture can be defined as sharing, based on basic ideas learned in an organization obtained from the environment and problem solving from external and internal adaptations taught to new members of the organization as appropriate steps and ways to solve a problem. Effective knowledge sharing can have a significant impact on a business's bottom line. This also highlights the need of creating a culture of information sharing inside a business. Among the many cultural factors that could influence employees' propensity to share what they know, the management style of the company is the most significant (Sari, 2022).

2. Organizational Structure

The organizational structure is a division of clearly designated divisions, with responsibilities for the work and activities of the division of labor that are interconnected with each other. Knowledge assets are becoming increasingly important to businesses as the knowledge-based economy expands at an exponential rate. The ability to solve problems, make sound decisions, boost productivity, and create new solutions relies heavily on an organization's ability to effectively use its knowledge in the modern business environment. Organizations require a knowledge-based framework for efficient knowledge management. The structure of an organization should support its goals, facilitate learning and growth, and facilitate ongoing improvement in line with the company's strategy (Helmy et al., 2019).

3. Training

Training is essential for individuals to change, by providing them with new knowledge and skills. Al & Al, (2020) defining training is sending information to members of the organization that increases the effectiveness and productivity of the organization.

4. Reward System

For knowledge sharing without consideration of what should be obtained or not as a result of knowledge sharing. Leaders should consider pooling and sharing knowledge when forming and creating reward systems. Ideas are released during the knowledge sharing process. Knowledge is a strategic asset that may boost an organization's efficiency and give it a leg up in the marketplace. Individuals are the source of an organization's information, and knowledge sharing is the process of disseminating that knowledge to build up the organization's knowledge resources. Knowledge sharing, however, is dependent on employees' openness to doing so (Abusweilem & Abualoush, 2019).

5. Support from leadership

In the creation of organizational value whose orientation is based on knowledge, it can be explained that support from superiors will affect positively and finally support from leaders will have a positive outlook towards knowledge sharing. Knowledge and leadership processes identify implications when determining the most effective leadership style to achieve knowledge transfer (Żywiłek et al., 2022)

RESEARCH METHOD

Population and Sample

A population is a statistical sample from which inferences can be made about a larger group of similar items or subjects (Sari, Taifur, et al., 2022). The population in this study is The respondents in this study are the entire Village Apparatus of Kumun Debai District in Sungai Penuh City. To determine the minimum sample needed is the full sampling method (Satria et al., 2020). The village in Kumun Debai sub-district consists of 9 villages consisting of : Kumun Hilir village, Kumun Mudik village, Air Teluh village, Sandaran Galeh village, Debai village, Pinggir Air village, Renah Kayu Embun village, Ulu Air village and Muara Jaya village. So that from the entire village apparatus in 9 villages in Kumun Debai District, Sungai Penuh City, a sample of 153 respondents was obtained.

Data Analysis and Hypothesis Testing Techniques

The Structural Equation Model (SEM) was used for the model testing in this investigation. Using a combination of factor analysis and simultaneous equation modeling from the field of econometrics, structural equation modeling (SEM) examines the interrelationships between variables in a model (Pardede et al., 2019). The appropriateness of a model is determined by comparing it to certain goodness-of-fit standards. In order to determine whether or not a model should be accepted, a number of conformance indices and threshold values are employed. This study's findings should paint a substantial picture of the state of the field.

Data Sources And Data Collection Techniques

The data for this study was collected using surveys. Interviews are conducted, and respondents are given a questionnaire to fill out.

Data Sources

Primary data collected through in-depth interviews with Village Officials and distribution of questionnaires to the same in the Kumun Debai District of Sungai Penuh City. An summary of village growth in Kumun Debai, a subdistrict of Sungai Penuh City, compiled from secondary sources such as collected data and documents and processed written reports.

Hypothesis Testing

In order to answer research questions and expose particular social phenomena, researchers must first analyze the data at their disposal, which is the process of simplifying the data into a form that is easier to read and interpret. This study will employ a multilevel structural model for its research, and SEM (Structural Equation Modelling) analysis techniques will be employed to test the hypotheses put forth (Elizar et al., 2017). A good model must meet the criteria of a structural equation model (Sari, Abdallah, et al., 2022):

1. The degree of freedom (DF) must be positive.
2. The required Chi square value with a probability value of $p < 0.05$.
3. CMIN/DF, is The Minimum Sample Discrepancy Function divided by degree of freedom. CMIN/DF is nothing but a relative chi square χ^2 statistic. When the relative χ^2 value is less than 2.0 or 3.0 is indicative of an acceptable fit between the model and the data
4. Incremental fit for GFI (Goodness of Fit Index), adjusted GFI (AGFI), Tucker-Lewis
5. Index (TLI) and Normed Fit Index (NFI), range from 0 (poor fit) to 1.0 (perfect fit). The recommended value is > 0.9 .
6. *Root Mean Square Residual (RMR) and Root Mean Square Error of Approximation (RMSEA) values between 0.05 - 0.08 are acceptable measures.*
7. *Root Mean Square error of approximation (RMSEA).* RMSEA values between 0.05 and 0.08 are acceptable
8. Goodness of fit (AGFI) with degree of freedom for null model, recommended value is equal or > 0.90

RESULTS AND DISCUSSION

Model Test Results

Picture 1: Full Model-Structural Equation Model (SEM) Testing Result

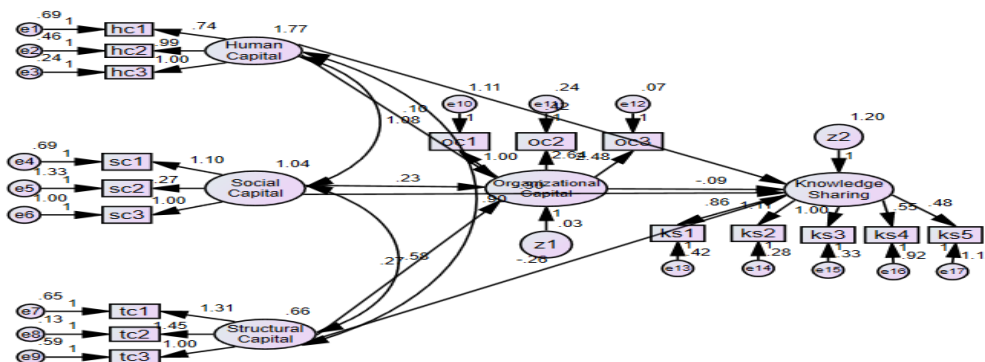

With the results of model testing are:

1. Absolute Fit Indices

- 1) The result of DF is 109 which is interpreted as "accepted" because it is positive
- 2) The result of X^2/DF is 1.052 which is interpreted as "accepted" because the lowest limit is 1.0, the highest limit is 2.03

2. Incremental Fit Indices

- 1) The result of GFI = 0.773, AGFI = 0.682, TLI = 0.808 and CFI = 0.846 which is interpreted as "accepted" because it is in the criteria of Values ranging from 0-1, closer to 1 the better
- 2) The result of RMR = 0.040 and RMSEA = 0.042 which is interpreted as "accepted" because it is on the criteria of < 0.08

3. Parsimony Fit Indices

The result of PNFI = 0.647 and PCFI = 0.678 which is interpreted as "accepted" because it is in the criteria of Values ranging from 0 -1

Based on the explanation of the results of the model testing above, it was produced that the model in this study was acceptable.

Hypothesis Testing

Hypothesis testing in this study using a comparison of the results of the Critika Ratio and P. With the criterion of the value of the Critical Ratio > 1.96 or the P value is below 0.05. The results of hypothesis testing can be seen in table 1 below:

Table 1. Model Test Results

	Estimate	S.E.	C.R.	P	Label
Organizational_Capital <--- Human_Capital	.100	.048	2.080	.038	par_9
Organizational_Capital <--- Social_Capital	.229	.068	3.383	***	par_10
Organizational_Capital <--- Structural_Capital	.267	.077	3.480	***	par_11
Knowledge_Sharing <--- Organizational_Capital	-.091	.824	-.111	.912	par_12
Knowledge_Sharing <--- Human_Capital	.419	.206	2.034	.042	par_13
Knowledge_Sharing <--- Structural_Capital	-.260	.341	-.764	.445	par_14
Knowledge_Sharing <--- Social_Capital	-.303	.342	-.885	.376	par_22

From the table above, the results of Hypothesis testing are:

1. Hypothesis Testing between Human Capital and Organizational Capital is with the results of CR = 2.080 and P is = 0.038. With the conclusion that Human Capital has a positive influence on Organizational Capital is acceptable. Because it meets the criteria where $CR > 1.96$ and $P < 0.05$
2. Hypothesis testing between Social Capital and Organizational Capital is with the result CR = 3.383 and P is = 0.000. With the conclusion that Social Capital has a positive effect on Organizational

Capital is acceptable. Because it meets the criteria where $CR > 1.96$ and $P < 0.000$

3. Hypothesis Testing between Structural Capital and Organizational Capital is with the result $CR = 3.480$ and $P = 0.000$. With the conclusion that Structural Capital has a positive effect on Organizational Capital is acceptable. Because it meets the criteria where $CR > 1.96$ and $P < 0.000$

4. Hypothesis Testing between Organizational Capital Against Knowledge Sharing is with the results $CR = -0.111$ and $P = 0.912$. With the conclusion that Organizational Capital has no effect on Knowledge Sharing. Because it does not meet the criteria where $CR > 1.96$ and $P < 0.05$.

5. Hypothesis Testing between Human Capital Against Knowledge Sharing is with the result $CR = 2.034$ and $P = 0.042$. With the conclusion that Human Capital has a positive effect on Knowledge Sharing is acceptable. Because it meets the criteria where $CR > 1.96$ and $P < 0.000$

6. Hypothesis Testing between Structural Capital and Knowledge Sharing is with the result $CR = -0.764$ and $P = 0.445$. With the conclusion that Structural Capital has no effect on Knowledge Sharing. Because it does not meet the criteria where $CR > 1.96$ and $P < 0.05$.

7. Hypothesis Testing between Social Capital Against Knowledge Sharing is with the result $CR = -0.885$ and $P = 0.376$. With the conclusion that Social Capital has no effect on Knowledge Sharing. Because it does not meet the criteria where $CR > 1.96$ and $P < 0.05$.

Analysis of Direct Effect, Indirect Effect and Total Effect

The degree of influence between concepts can be examined by analyses of their direct, indirect, and cumulative effects. A one-way arrow represents an effect that has a direct impact. An indirect effect is one that emerges as a result of other factors' effects. In this context, "total effect" refers to the combined impact of the many interrelated factors present in the theoretical framework.

Table 2. Total Effect

	Structural_Capital	Social_Capital	Human_Capital	Organizational_Capital	Knowledge_Sharing
Organizational_Capital	.385	.415	.237	.000	.000
Knowledge_Sharing	-.205	-.293	.484	-.046	.000

Table 3 Direct Effect

	Structural_Capital	Social_Capital	Human_Capital	Organizational_Capital	Knowledge_Sharing
Organizational_Capital	.385	.415	.237	.000	.000
Knowledge_Sharing	-.188	-.274	.495	-.046	.000

Table 4 Indirect Effect

	Structural_Capital	Social_Capital	Human_Capital	Organizational_Capital	Knowledge_Sharing
Organizational_Capital	.000	.000	.000	.000	.000
Knowledge_Sharing	-.018	-.019	-.011	.000	.000

From the results of Tables 2, 3 and 4 conclusions are made from each influence into a matrix:

Table 5. Matrix Path Coefficient of Total Effect, Direct Effect and Indirect Effect

Description	Direct Effect	Indirect Effect	Total Effect
The Influence of Human Capital on Organizational Capital	0,237	-	0,237
The Influence of Social Capital on Organizational Capital	0,415	-	0,415
The Influence of Structural Capital on Organizational Capital	0,385	-	0,385
The Influence of Human Capital on Knowledge Sharing	0,495	-0,011	0,484
The Influence of Social Capital on Knowledge Sharing	-0,274	-0,019	-0,293
The Influence of Structural Capital on Knowledge Sharing	-0,188	-0,018	-0,205
The Influence of Organizational Capital on Knowledge Sharing	-0,046	-	-0,046

From the table of Matrix Coefficients of Total Influence Path, Direct Influence and Indirect Influence above, the results are obtained:

1. The direct influence between Human Capital on Organizational Capital is 0.495. The indirect influence between Human Capital through Organizational Capital on Knowledge Sharing is -0.011. This suggests that having a direct impact is preferable to having an indirect impact (0.495 -0.011). This study therefore concludes that Organizational Capital does not buffer the effect of Human Capital on Knowledge Sharing.
2. Social capital has a -0.274 correlation with organizational capital. Knowledge sharing is negatively affected by Social Capital (-0.019) as a result of its indirect effect via Organizational Capital. As a result, the ratio of direct to indirect impact is -0.274 to -0.019. Thus, this research suggests that organizational capital serves as a mediator between social capital and the propensity to share knowledge.
3. Structural Capital has a -0.188 correlation with Organizational Capital. Knowledge Sharing is -0.018 more likely to occur when structural capital is present rather than when organizational capital is present. As a result, the ratio of direct to indirect impact is -0.188 to -0.018. Therefore, the results of this investigation suggest that organizational capital serves as a mediator between structural capital and knowledge sharing.

Squared Multiple Correlations

For the result of *Squared Multiple Correlations* :

Table 6. Squared Multiple Correlations

	Estimate
Organizational_Capital	.910
Knowledge_Sharing	.056

From table 6 which is the result of Squared Multiple Correlations, the results are obtained :

1. Structural capital, social capital, and human capital influence 91% of organizational capital in village apparatus in Kumun Debai District, Sungai Penuh City
2. Structural capital, social capital, human capital and organizational capital have an effect of 5.6% on knowledge sharing in village apparatus in Kumun Debai District, Sungai Penuh City

CONCLUSION

1. The conclusion of this study was found that: Of the 7 hypotheses in this study, Human capital has a positive and significant effect on the organizational capital of village equipment in Kumun Debai District, Sungai Penuh City, social capital has a positive and significant effect on the organizational capital of village equipment in Kumun Debai District, Sungai Penuh City, and structural capital has a positive and significant effect on the organizational capital of village equipment.
2. The organizational capital of village apparatus in Kumun Debai District, Sungai Penyuh City, is 91% influenced by human capital, social capital, and structural capital. Knowledge sharing in rural infrastructure is influenced by human, social, structural, and organizational factors to the tune of 5.6% in the Kumun Debai District of Sungai Penuh City..

SUGGESTION

1. It is necessary to increase the variable of intellectual capital in village apparatus in Kumun Debai District, Sungai Penuh City, so that it can increase knowledge sharing in village apparatus in Kumun Debai District, Sungai Penuh City.
2. In order to increase organizational capital and knowledge sharing, village apparatus in Kumun Debai District, Sungai Penuh City can reliably cultivate the human capital, social capital, and structural capital that make up the intellectual capital dimension.

It is recommended for future studies to be able to add other variables outside this study, as well as add from the number of village devices with a wider population scope that can be used as a sample.

REFERENCES

- Abusweilem, M. A., & Abualoush, S. (2019). The impact of knowledge management process and business intelligence on organizational performance. *Management Science Letters*, 9(12), 2143–2156. <https://doi.org/10.5267/j.msl.2019.6.020>
- Achyani, F. (2019). The Determinant Accountability Of Village Funds Management (Study in the Villages in Wonogiri District). *Riset Akuntansi Dan Keuangan Indonesia*, Vol 4, No 2 (2019), 118–135. <https://doi.org/10.23917/reaksi.v4i2.8521>
- Agustami, S., & Rahman, A. (2015). Pengaruh Intellectual Capital Terhadap Kinerja Keuangan Dan Pertumbuhan Perusahaan. *Jurnal Riset Akuntansi Dan Keuangan*, 3(2), 711. <https://doi.org/10.17509/jrak.v3i2.6615>
- Agustiningsih, M. (2020). Penerapan Good Governance Dalam Pengelolaan Dana Desa Studi Kasus Pada Kabupaten Kampar. *Pekbis Jurnal*, 12, No.3, 235–247. <https://pekbis.ejournal.unri.ac.id/index.php/JPEB/article/viewFile/7888/6800>
- Al, Z., & Al, F. (2020). The Role of Knowledge Sharing in Organizational Performance. *Information and Knowledge Management*, 30–38. <https://doi.org/10.7176/ikm/10-2-05>
- Amri, F., Yusnita, I., & Sari, A. E. (2020). Pengaruh Reward Terhadap Knowledge Sharing Perangkat Desa Berdampak Peningkatan Partisipasi Masyarakat. *Jurnal Ilmiah Akuntansi Manajemen*, 3(2), 104–118. <https://doi.org/10.35326/jiam.v3i2.1031>
- Arumi, M. S., Aldrin, N., & Murti, T. R. (2019). Effect of Organizational Culture on Organizational Citizenship Behavior with Organizational Commitment as a Mediator. *International Journal of Research in Business and Social Science* (2147- 4478), 8(4), 124–132. <https://doi.org/10.20525/ijrbs.v8i4.274>
- Chan, K. H., Chu, S. K. W., & Wu, W. W. Y. (2012). Exploring the Correlation Between Knowledge Management Maturity and Intellectual Capital Efficiency in Mainland Chinese Listed Companies. *Journal of Information & Knowledge Management*. <https://doi.org/10.1142/S0219649212500177>
- Elizar, Suripin, & Wibowo, M. A. (2017). Model of Construction Waste Management Using AMOS-SEM for Indonesian Infrastructure Projects. *MATEC Web of Conferences*, 138. <https://doi.org/10.1051/mateconf/201713805005>
- Faeni, Dewi Puspaningtyas. (2015). HRM Practices and Existence of Knowledge Management Agent in Higher Education. *Information and Knowledge Management*, 5(3) 2224-5758. <https://www.iiste.org/Journals/index.php/IKM/article/view/20581>

- Faeni, Dewi Puspaningtyas., Ratih Puspitaningtyas Faeni, (2016) Cognitive Style and Composition of Employees in Shaping Intellectual Sales Team. *Business Economig Social Science Humanities Conference (BESSH)*. Volume 11. September 2016.. Willey Publisher.
- Faeni, Dewi Puspaningtyas., Ratih Puspitaningtyas Faeni, (2016) Manager Characteristics, HR Renewal, Marketing Strategies, Partnership Motivation, Work Orientation, Work Standardization, on SMES Business Resilience in the Competition: Insurance Healthcare Services. *Scholedge International Journal of Management & Development* Volume 3, Issue 2. Pages 32-48 Publisher. Scholedge the Scholarly Publishing
- Faeni, Dewi Puspaningtyas., Ratih Puspitaningtyas, (2020) The Role Of Management Control System On Firm Performance. *Talent Development & Excellence*, 12(1), 1629-1639. <http://www.iratde.com/>
- Faeni, Dewi Puspaningtyas., Ratih Puspitaningtyas, Yuliansyah Yuliansyah. (2022). The COVID-19 Pandemic Impact on the Global Tourism Industry SMEs: A Human Capital Development Perspective. *Review of International Business and Strategy*, 32(4), 2059-6014. <https://doi.org/10.1108/RIBS-08-2021-0116>
- Faeni, Dewi Puspaningtyas., Yudi Nugroho. (2017) The Role Of Women Entrepreneurs Leadrships, Social Capital and Absorptive Capacity Through Skills Upgrading Concept In Small To Medium Enterprises In Jakarta, Indonesia. *International Journal of Pure and Applied Mathematics*, 116(24), 511-520. <http://www.ijpam.eu/>
- Gan, K., & Saleh, Z. (2008). Intellectual capital and corporate performance of technology-intensive companies: Malaysia evidence. *Asian Journal of Business and Accounting*, 1(1), 113–130.
- Helmy, I., Adawiyah, W. R., & Banani, A. (2019). Linking psychological empowerment, knowledge sharing, and employees' innovative behavior in Indonesian SMEs. *Journal of Behavioral Science*, 14(2), 66–79. https://api.elsevier.com/content/abstract/scopus_id/85076017457
- Juneja, J. A., & Amar, A. D. (2018). An organizational capital decision model for knowledge-intensive organizations. *IEEE Transactions on Engineering Management*, 65(3), 417–433. <https://doi.org/10.1109/TEM.2018.2790898>
- Li, P., Li, F. W., Wang, B., & Zhang, Z. (2018). Acquiring organizational capital. *Finance Research Letters*, 25, 30–35. <https://doi.org/10.1016/j.frl.2017.10.004>
- Liu, C. H., Horng, J. S., Chou, S. F., Huang, Y. C., & Chang, A. Y. (2018). How to create competitive advantage: the moderate role of organizational learning as a link between shared value, dynamic capability, differential strategy, and social capital. *Asia Pacific Journal of Tourism Research*, 23(8), 747–764. <https://doi.org/10.1080/10941665.2018.1492943>
- Martín-de-Castro, G., Navas-López, J. E., López-Sáez, P., & Alama-Salazar, E. (2006). Organizational capital as competitive advantage of the firm. *Journal of Intellectual Capital*, 7(3), 324–337. <https://doi.org/10.1108/14691930610681438>
- Pardede, A. M. H., Sembiring, Y. B., Iskandar, A., Pitasari, D. R., Sriadhi, S., Rianita, D., Arifin, M., Ririhena, M. Y., Siregar, N. A., Supriyono, Sari, A. E., Tondo, S., Zarlis, M., Winarno, E., & Tulus. (2019). Implementation of Data Mining to Classify the Consumer's Complaints of Electricity Usage Based on Consumer's Locations Using Clustering Method. *Journal of Physics: Conference Series*, 1363(1). <https://doi.org/10.1088/1742-6596/1363/1/012079>
- Prasetya, E. M., Utami, H. N., & Prasetya, A. (2016). Pengaruh Human Capital, Information Capital dan Organizational Capital terhadap kinerja karyawan (Studi Pada Karyawan PT>PLN (Persero) Unit Induk Pembangunan VIII Surabaya). *Jurnal Administrasi Bisnis (JAB)*, Vol 40 No.(1).
- Sari, A. E. (2022). Pengaruh Knowledge Sharing Terhadap Knowledge Management Pegawai Di Sekretariat Daerah Kabupaten Kerinci Yang Dimediasi Oleh Transfer Of Training. *Bussman Journal: Indonesian Journal of ...*, 2(1), 1–14. <https://doi.org/10.53363/buss.v2i1.15>
- Sari, A. E., Abdallah, Z., Siswadi, F., Maryanto, & Haryono, G. (2022). Improving Financial and Marketing Management Based Digital Application On SMEs Batik Tulis Incung Kerinci. *International Journal of Engagement and Empowerment*, 2(3), 1–11.
- Sari, A. E., Salamah, S., & Albetris, A. (2019a). Dampak Dimensi Intellectual Capital Terhadap Knowledge Management Pendamping Desa di Kabupaten Kerinci. *J-MAS (Jurnal Manajemen Dan Sains)*, 4(2), 220–227. <https://doi.org/10.33087/jmas.v4i2.102>
- Sari, A. E., Taifur, W. D., & Muharja, F. (2022). Factors Affecting The formation of Tourism Village : Focusing on Components Tourism Supply in Indonesia. 6(4), 9661–9670.
- Sari, A. E., Yusnita, I., & Albetris. (2022). Pengaruh Human Capital dan Social Capital Terhadap Intellectual Capital Dengan Organizational Citizenship Behaviour sebagai Variabel Mediasi Pada Perangkat Desa di Kabupaten Kerinci. *Ekonomis: Journal of Economics and Business*, 6(1), 296–303. <https://doi.org/10.33087/ekonomis.v6i1.510>
- Satria, E., Yusnita, I., & Sari, A. E. (2020). Peningkatan Kinerja Pemasaran UMKM Melalui Dimensi Kewirausahaan di Kabupaten Kerinci. *J-MAS (Jurnal Manajemen Dan Sains)*, 5(2), 172. <https://doi.org/10.33087/jmas.v5i2.177>
- Yuli Ramanda, B. M. A. (2001). Human capital, relational capital.
- Yusnita, I., Amri, F., & Sari, A. E. (2021). Pengaruh Lingkungan Kerja Fisik Dan Disiplin Terhadap Kinerja Dengan Motivasi Kerja Sebagai Variabel Moderating Pada Pegawai Di Kantor Camat Kabupaten Kerinci. *Bussman Journal: Indonesian Journal of Business and Management*, 1(3), 427–442. <https://doi.org/10.53363/buss.v1i3.19>

- Zhang, M., Qi, Y., & Guo, H. (2017). Impacts of intellectual capital on process innovation and mass customisation capability: direct and mediating effects. *International Journal of Production Research*, 55(23), 6971–6983. <https://doi.org/10.1080/00207543.2017.1343505>
- Żywiołek, J., Tucmeanu, E. R., Tucmeanu, A. I., Isac, N., & Yousaf, Z. (2022). Nexus of Transformational Leadership, Employee Adaptiveness, Knowledge Sharing, and Employee Creativity. *Sustainability (Switzerland)*, 14(18), 1–16. <https://doi.org/10.3390/su141811607>



CHAPTER 5

Financial Analysis in Industry PT Telkom Indonesia

Demmy Puspita SUGIADI

Sekolah Tinggi Manajemen IPMI, Indonesia
demmy.sugiadi@ipmi.ac.id
Orcid: 0009-0001-0307-8861

Wiwiek Mardawiyah DARYANTO

Sekolah Tinggi Manajemen IPMI, Indonesia
wiwiek.daryanto@ipmi.ac.id
Orcid: 0000-0003-3582-5857

ABSTRACT

The purpose of the research is to study the descriptive terms that are used in studying something. Information gathered from the financial summary as a source. Companies that are listed on the Indonesia Stock Exchange, such as PT. Telekomunikasi Indonesia, Tbk, are accessible through the website located at www.idx.co.id. The analysis ratio that was utilized for the data analysis. The findings of the study reveal the percentage of liquidity at PT. According to the ratio of fluent And ratio quickly , Telekomunikasi Indonesia, Tbk is at the terrible situation . _ Fairness in proportions at PT. The Indonesian communication media seen from the perspective of the requirement mark proportion Not yet acceptable, but regarded from the perspective of the need to proportion source. Power Already ok . PT's share of the proportional profit. Good news for Telekomunikasi Indonesia, Tbk in terms of its return on equity and return on investment, according to the facet analysis. Movement of proportions at PT. Indonesian Telecommunications in its current situation Although good based on the study of the rotation of supply, the actual state is poor because of the turnover of assets.

Keywords : Solvency, Liquidity, Profitability, Activity.

1. INTRODUCTION

The telecommunications industry has experienced significant growth in the last few decades, driven by technological developments and increasing demand for communications services. PT Telkom Indonesia, as one of the leading telecommunications companies in Indonesia, continues to adapt to changes in the industrial environment and aims to maintain its position as a major player in this industry. Financial analysis is an important tool used to evaluate a company's financial performance. In the context of PT Telkom Indonesia, financial analysis can provide valuable insights into a company's financial stability, operational performance, and future growth potential. By analyzing the company's financial statements, we can identify the strengths, weaknesses, opportunities and challenges faced by PT Telkom Indonesia in the context of a dynamic telecommunications industry. The purpose of this study is to conduct an in-depth financial analysis of PT Telkom Indonesia, focusing on key aspects such as the company's liquidity, profitability, capital structure and cash flow. In this case, we will analyze PT Telkom Indonesia's financial statements over the past several years and use relevant financial ratios to evaluate the company's financial performance.

This research is expected to provide a better understanding of the financial health of PT Telkom Indonesia and provide valuable insights for stakeholders, including company management, investors and other decision makers in the telecommunications industry. In addition, this research can be the basis for the development of better financial strategies and policies in the future. The research methodology will involve a quantitative analysis of PT Telkom Indonesia's financial statements, including the income statement, balance sheet, and cash flow statement. We will also use relevant financial ratios to evaluate the company's financial performance. In addition, we will consider external factors that affect the telecommunications industry in general, such as technological developments, government regulations and market competition.

The limitations of this study are the limited data available and time constraints which may affect the level of depth and completeness of the analysis. However, we will try our best to provide a comprehensive and accurate analysis within the limitations. It is expected that the results of this study can provide a better understanding of the financial condition of PT Telkom Indonesia and the factors that influence the company's financial performance in the context of the telecommunications industry. This information can be a basis for making better decisions in managing company finances and formulating appropriate strategies to face challenges and take advantage of opportunities in the future.

This research will analyze the main financial ratios such as liquidity ratios, profitability ratios, debt ratios, and cash flow analysis. In addition, a comparison of PT Telkom Indonesia's financial performance with similar companies in the telecommunication industry will be carried out to see the relative position and performance of the company in the market. In addition, economic, political and technological factors that affect the telecommunications industry in general, as well as changes in government regulations that may impact the financial performance of PT Telkom Indonesia will also be considered. As a financial analysis research, the data used will be sourced from PT Telkom

Indonesia's official financial reports available to the public, such as annual reports, quarterly financial reports, and related financial reports. Apart from that, other relevant data will also be used to provide a better context in the analysis. It is hoped that this research can provide useful insights for PT Telkom Indonesia's stakeholders, such as company management, investors, financial analysts, and the general public who are interested in the company's financial condition. It is also hoped that the results of this research can contribute to the development of knowledge about financial analysis in the telecommunications industry, as well as being the basis for further research in this field.

2. RESEARCH METHODS

2.1 Data Collection: The data used can come from PT Telkom Indonesia's financial reports, such as annual reports, quarterly financial reports, and other related reports. In addition, other relevant data such as telecommunications industry data, market data and economic data can be collected to provide a broader context in the analysis.

2. 2 Identification of Financial Indicators: The financial indicators to be used in the analysis must be identified. For example, liquidity ratios (such as current ratio, quick ratio), profitability ratios (such as net income, profit margin), debt ratios (such as debt to equity ratio, debt to asset ratio), and cash flow analysis (such as cash flow from operating activities , investment, and financing). Selection of financial indicators should be based on research objectives and characteristics of the telecommunications industry.

2. 3. Analysis of Financial Ratios: The relevant financial ratios are calculated using the data that has been collected. Appropriate formulas are used to calculate the desired financial ratios based on identified financial indicators.

2. 4. Interpretation of Results: The results of financial ratio analysis are interpreted to gain a better understanding of PT Telkom Indonesia's financial condition. These results can be compared with previous performance, peers in the telecommunications industry, or relevant industry standards. The interpretation must describe the strengths, weaknesses, opportunities and challenges faced by the company.

2. 5. Conclusions and Recommendations: Conclusions are drawn based on the results of the analysis and interpretation that have been carried out. Recommendations can be given for improvement or development of the company's financial policies.

3. RESULTS AND DISCUSSION

3.1 Results of Financial Ratio Analysis:

The results of a completed financial ratio analysis are able to give data and comparisons that are reflective of the company's current financial state. These results may include a cash flow analysis, liquidity ratios, profitability ratios, and debt ratios. For instance, if a firm has a strong liquidity ratio, it suggests that the company is able to pay its short-term commitments, and if a company has a high profitability ratio, it shows that the company is doing well in terms of its profitability.

(In million IDR)

Table-1 : Financials Ratio Analysis for Five Years

No	name of Ratio	Formulas & circulation	state US	2017	2018	2019	2020	2021
Overalls performance Measures								
1	earning Ratio	$\frac{\text{Market price per share}}{\text{Net income per share}}$	Times .x	<u>4.040</u> 223.55 18.07	<u>3.990</u> 182.03 21.91	<u>4.230</u> 188,40 10:45 p.m	<u>4.020</u> 210.01 19,14	<u>3.770</u> 249.94 15.08
2	return on Assets	$\frac{\text{Net Income} + \text{Interest} (1-\text{Tax rate})}{\text{Total Assets}}$	percent x100%	<u>12.029</u> 198,484 16.5	<u>15.740</u> 206,196 13,1	<u>17.696</u> 221,208 12.5	<u>20.578</u> 246,943 12.0	<u>18.621</u> 227,184 12,2
3	return on invested Capital	$\frac{\text{Net Income} + \text{Interest} (1-\text{Tax Rate})}{\text{Long Term Liabilities} + \text{Shareholdersequity}}$	percentx100%	<u>12.029</u> 264,528 0.04	<u>15.740</u> 224,662 0.07	<u>17.696</u> 233,989 0.07	<u>20.578</u> 266,971 0.07	<u>18.621</u> 312,594 0.05
4	return on Shareholders equity	$\frac{\text{NetIncome}}{\text{Shareholders equity}}$	percentx100%	<u>30.369</u> 223.55 0.13	<u>31.921</u> 182.03 0.17	<u>25.400</u> 188,40 0.13	<u>25.986</u> 210.01 0.12	<u>35.928</u> 249.94 0.14
Profitability Measures								
5	gross margins Percentages	$\frac{\text{Gross Margins}}{\text{Net Sales Revenue}}$	percentx100%	<u>43.933</u> 92,713 0.47	<u>36.845</u> 98,910 0.39	<u>42.394</u> 99,561 0.42	<u>43.505</u> 102,527 0.42	<u>47.563</u> 121,646 0.39
6	Profit margins	$\frac{\text{Net Income}}{\text{Net Sales Revenue}}$	percent x100%	<u>30.369</u> 92,713 0.32	<u>31.921</u> 98,910 0.32	<u>25.400</u> 99,561 0.25	<u>25.986</u> 102,527 0.25	<u>35.928</u> 121,646 <u>0.29</u>
7	earning Per Share	$\frac{\text{Net Income}}{\text{No of shares Outstanding}}$	IDR	<u>30.369</u> 223.55 0.13	<u>31.921</u> 223.55 0.14	<u>25.400</u> 223.55 0.11	<u>25.986</u> 223.55 0.11	<u>35.928</u> 223.55 0.16
8	Cash Realization	$\frac{\text{Cash generated by Operation}}{\text{Net Income}}$	Timesx	<u>49.405</u> 30,369 1.62	<u>45.671</u> 31,921 1.43	<u>54.949</u> 25,400 2,16	<u>65.317</u> 25,986 2,5	<u>68.353</u> 35,928 1,9

Contemporary Exploration of Social Sciences in the Post Pandemic Era - 1

		test of Investments Utilization						
9	Assets turnovers	<u>Sales Revenue</u> Total Assets	Times x	<u>128,256</u> 198,484 0.64	<u>130,784</u> 206,196 0.63	<u>135,567</u> 221,208 0.61	<u>136,462</u> 246,943 0.54	<u>143,210</u> 277,184 0.51
10	invested Capital turnovers	<u>Sales Revenue</u> <u>Long Term</u> <u>Liabilities</u> + <u>Shareholdersequity</u>	Timesx	<u>128,256</u> 133,691 0.95	<u>130,784</u> 141,542 0.92	<u>135,567</u> 145,150 0.93	<u>136,462</u> 159,488 0.85	<u>143,210</u> 184,300 0.77
11	equity turnovers	<u>Sales Revenue</u> Shareholders equity	Times x	<u>128,256</u> 92,713 1.38	<u>130,784</u> 98,910 1.32	<u>135,567</u> 99,561 1.36	<u>136,462</u> 102,527 1.33	<u>143,210</u> 121,646 1.17
12	Capital intensity	<u>SalesRevenue</u> properties, plans, and Equipment	Timesx	<u>128,256</u> 53,210 2.41	<u>130,784</u> 48,324 2.70	<u>135,567</u> 52,537 2.58	<u>136,462</u> 45,434 3.00	<u>143,210</u> 51,674 2.77
13	Days Cash	<u>Cash</u> Cash Expenses *365	Days	<u>25,145</u> 0.263 95.60	<u>17,439</u> 0.354 49.26	<u>18,242</u> 0.265 68.83	<u>20,589</u> 0.366 56.25	<u>38,311</u> 0.563 68.04
14	Days Acceptable	<u>A/R</u> Sales * 365	Days	<u>9,222</u> 0.423 21.80	<u>11,414</u> 0.532 21,454	<u>11,797</u> 0.435 27,11	<u>11,339</u> 0.514 22.06	<u>9,685</u> 0.456 21,23
15	Days Inventory	<u>Inventory</u> cost of Sales * 365	Days	<u>34,576</u> 0.876 39.47	<u>44,476</u> 0.662 67,18	<u>49,433</u> 0.693 71.33	<u>51,498</u> 0.773 66.62	<u>50,331</u> 0.689 73.04
16	Inventory turn Over	<u>cost of Sales</u> Inventory	Times x	<u>233,569</u> 34,576 6.75	<u>249,766</u> 44,476 5.61	<u>332,698</u> 46,786 7.11	<u>300,544</u> 42,890 7.00	<u>341,877</u> 43,787 7.80
17	Working Capital turnovers	<u>SalesRevenue</u> Working Capital	Timesx	<u>128,256</u> 6,789 18.89	<u>130,784</u> 13,722 9.53	<u>135,567</u> 15,241 8.89	<u>136,462</u> 16,885 8.08	<u>143,210</u> 17,951 7.97
18	Current Ratio	<u>Current Ass t</u> Current Liabilities	Ratio xx	<u>198,484</u> 86,354 2.29	<u>206,196</u> 88,893 2.31	<u>221,208</u> 103,958 2.12	<u>246,943</u> 126,054 1.95	<u>277,184</u> 131,785 2.10
19	AC ID test quick Ratio	<u>Monetary Current</u> <u>Assets</u> Current Liabilities	Ratioxx	<u>125,988</u> 86,354 1.45	<u>132,776</u> 86,354 1.53	<u>155,233</u> 103,958 1.49	<u>137,976</u> 126,054 1.09	<u>142,898</u> 131,785 1.08
		test of Financial Condition						
20	Financial leverage Ratio	<u>Total</u> Asset Shareholders equity	percentx100%	<u>198,484</u> 92,713 2.14	<u>206,196</u> 98,910 2.08	<u>221,208</u> 99,561 2.22	<u>246,943</u> 102,527 2.40	<u>277,184</u> 121,646 2.27
21	Debt/ Equiries Ratio	<u>Total Liabilities</u> Shareholders		<u>86,354</u> 92,713	<u>86,354</u> 98,910	<u>103,958</u> 99,561	<u>126,054</u> 102,527	<u>131,785</u> 121,646



		equity	percent x100%	0.93	0.87	1.04	1.22	1.08
22	Debt/Capitalization	<u>Long Term Liabilities</u> <u>Long Term Liabilities</u> + <u>Shareholder equity</u>	percentx100%	<u>40,978</u> 201,366	<u>42,632</u> 221,322	<u>45,589</u> 250,663	<u>56,961</u> 323,258	<u>62,654</u> 342,856
				0.20	0.19	0.18	0.17	0.18
23	Times Interested Earned	<u>Pretax Operating Profit + Interest</u> <u>Interest</u>	Timesx	<u>3,254</u> 2,543	<u>3,215</u> 2,566	<u>4,530</u> 3,255	<u>3,643</u> 5,656	<u>4,634</u> 3,932
				1.27	1.25	1.39	0.64	1.17
24	Cash Flow/Debit	<u>Cash generated</u> <u>Operation</u> Total <u>Debt</u>	percentx100%	<u>4,543</u> 46,788	<u>3,341</u> 50,788	<u>4,857</u> 49,677	<u>5,645</u> 43,899	<u>5,877</u> 52,899
				0.09	0.06	0.09	0.12	0.11
test of Dividend Policy								
25	Dividend Yields	<u>Dividend Per Share</u> <u>Market Price Per Share</u>	percent x100%	<u>223.55</u> 4,040	<u>182.03</u> 3,990	<u>188.40</u> 4,230	<u>210.01</u> 4,020	<u>249.94</u> 3,770
				0.053	0.045	0.040	0.052	0.063
26	Dividend Payouts	<u>Dividend</u> <u>Net Income</u>	percent x100%	2,543 4,423	1,587 5,346	4,678 5,889	2,892 3,566	1,896 4,432
				0.57	0.39	0.79	0.81	0.42

Table-2 : Trends and Interpretation Financial Ratio

name of Ratio	state US	2017	2018	2019	2020	2021	Trends and Interpretation
Price / Earnings Ratio	Times .x	18.07	21.91	10:45 p	19,14	15.08	the price/earnings ratio, also called the P/E ratio, tells investors how much a company is worth. We can see that the number is in fluctuating trend
return on Assets	percentx100%	16.5	13,1	12.5	12.0	12,2	Return on assets (ROA) measures how efficient a company's management is in generating profit from their total assets on their balance sheet. We can see that the number a to go down trend.
Return on Invested Capital	percentx100%	0.04	0.07	0.07	0.07	0.05	Return on invested capital (ROIC) is a calculation used to determine how well a company allocates its capital to profitable projects or investments. We can see that the number is in fluctuating trend
return on Shareholders equity	percentx100%	0.13	0.17	0.13	0.12	0.14	The return on shareholders' equity ratio shows how much money is returned to the owners as a percentage of the money they have invested or retained in the company. We can see that the number is in fluctuating trend

Contemporary Exploration of Social Sciences in the Post Pandemic Era - 1

gross margins Percentages	percentx100%	0.47	0.39	0.42	0.42	0.39	Gross margin is net sales less the cost of goods sold (COGS). In other words, it's the amount of money a company retains after incurring the direct costs associated by producing the goods it sells and the services it provides. We can see that the number is in a sideways trend
Profit margins	percentx100%	0.32	0.32	0.25	0.25	0.29	the profit margins ratio compares profit to sales and tells you how well the company is handling its finances overall. We can see that the number is in a sideways trend
earning Per Share	IDR	0.13	0.14	0.11	0.11	0.16	Earning Per Share indicates how much money a company makes for each share of its stock and is a widely used metrics for
							estimating corporate value. We can see that the number is in fluctuating trend.
Cash Realization	Timesx	1.62	1.43	2,16	2,5	1,9	Cash realization ratio measures how close a the company's net income is to be realized in cash. We can see that the number a to go up trend.
Assets turnovers	Timesx	0.64	0.63	0.61	0.54	0.51	Assets turnovers ratio measures the value of a company's sales or revenues relative to the value of its assets . We can see that the number is in a sideways trend
Invested Capital turnovers	Timesx	0.95	0.92	0.93	0.85	0.77	Invested capital turnover ratio is used to measure how well a company manages its working capital to support a given levels of sales. We can see that the number is in fluctuating trend.
equity turnovers	Timesx	1.38	1.32	1.36	1.33	1.17	Equity Turnover is a ratio comparing net revenue and average shareholders' equity to measure the efficiency at which a the company utilizes the equity capital contributed by stockholders. We can see that the number a to go down trend.
Capital intensity	Times x	2,41	2.70	2.58	3.00	2.77	Capital intensity indicates how much money is invested in producing one dollar/rupee of sales revenue. We can see that the number tends to go up trend.
Days Cash	Days	95.60	49,26	68,83	56,25	68.04	Days cash on hand represents the number of days a company can continue to pay its operating expenses with its available cash. We can see that the number is in fluctuating trend.
Days Acceptable	Days	21.80	21,454	27,11	22.06	21,23	Day's receivable, also known as the number of days of receivables, is a ratio to measure the number of days that a customer invoice is outstanding before it was collected. We can see that the number is in a sideways trend.
Days Inventory	Days	39,47	67,18	71.33	66,62	73.04	Days in inventory is an efficiency ratio that measures the average number of days the company holds its inventory before selling it. We can see that the number is in fluctuating trend.

Inventory turn Over	Timesx	6.75	5.61	7.11	7.00	7.80	Inventory turnovers refers to the amount of the time that passes from the day an item is purchased by a company until it is sold. We can see that the number a to go uptrend.
Working Capital turnovers	Timesx	18.89	9.53	8.89	8.08	7.97	Working capital turnover measures how effectively a business generates sales for every dollars of working capital put to use. We can see that the number tends to go down trend.
Current Ratio	Ratioxx	2.29	2.31	2.12	1.95	2.10	The current ratio is a liquidity ratio that measures whether a firm has enough resources to meet its short term obligations. We can see that the number is in fluctuating trend.
AC ID test quick Ratio	Ratio	1.45	1.53	1.49	1.09	1.08	the acid-test ratio, commonly known US the <u>quick ratio</u> , uses a firm's balance sheets data to indicate whether it has sufficient short-term assets to cover its short-term liabilities. We can see that the number is in fluctuating trend.
Financial LeverageRatio	percentx100%	2.14	2.08	2.22	2.40	2.27	A leverage ratio is any one of several financial measurements that look at how much capital comes in the form of debt (loans) or assesses the ability of a company to meet its financial obligations. We can see that the number is in fluctuating trend.
Debt/Equity Ratio	percentx100%	0.93	0.87	1.04	1.22	1.08	The debt-to-equity ratio measures your the company's total debt relative to the amount originally invested by the owners and the earnings that have been retained over time. We can see that the number a to go up trend.
Debt/Capitalization	percentx100%	0.20	0.19	0.18	0.17	0.18	The long-term debt to total capitalisation ratio shows the extent to which long-term interest-bearing debt is used for the the company's permanent financing. We can see that the number is in a sideways trend.
Times Interested Earned	Timesx	1.27	1.25	1.39	0.64	1.17	Times interest earned ratio is a solvency metric that evaluates whether a company is earnings enough money to pay its debt. We can see that the number is in fluctuating trend.
Cash Flow/Debit	percentx100%	0.09	0.06	0.09	0.12	0.11	The cash flow to debt ratio tells investors how much cash flow the company generated from its regular operating activities compared to its total debts. We can see that the number a to go up trend.

Contemporary Exploration of Social Sciences in the Post Pandemic Era - 1

Dividend Yields	percentx100%	0.053	0.045	0.040	0.052	0.063	Dividend Yield or dividend—the price ratio of a share is the dividends per share divided by the price per share. It is also a company's total annual dividends payments divided by its market capitalization, assuming the number of shares is constant. We can see that the number is going up trend.
Dividend Payouts	percentx100%	0.57	0.39	0.79	0.81	0.42	The Dividend Payout Ratio (DPR) is the number of dividends paid to shareholders with the total amount of net income the company generates. We can see that the number is in fluctuating trend.

Interpretation of Results: The results of financial ratio analysis need to be interpreted by considering the context of the telecommunications industry and the condition of the company as a whole. Good results can indicate a company's strengths and successes, while disappointing results can indicate problems or challenges that need to be addressed.

3.2 Comparison with Previous Years or Similar Companies: Financial Highlights

Table-3: Financial Highlights

Comprehensive Income Statement (In million IDR)	2021	2020	2019	2018	2017
Total Income	143,210	136,462	135,567	130,784	128,256
Total Debt	99,303	93,274	93,913	93,009	84,093
EBITDA	75,723	72,080	64,832	59,181	64,609
Gross Profit	47,563	43,505	42,394	38,845	43,933
Current year Profit	33,948	29,563	27,592	26,979	32,701
Profit for the year Attributable To :					
owner of The Parent Entity	24,760	20,804	18,663	18,032	22,145
Non-controlling interests	9,188	8,759	8,929	8,947	10,556



Total comprehensive income for the year	35,928	25,986	25,400	31,921	30,369
Attributable Comprehensive Income for the year To:					
owner of The Parent Entity	26,767	17,595	16,624	22,844	19,952
Non-controlling interests	9,161	8,391	8,776	9,077	10,417
Total Comprehensive Income for the year	35,928	25,986	25,400	31,921	30,369
Comprehensive Profit for the year that can be distributed To:					
owner of The Parent Entity	26,767	17,595	16,624	22,844	19,952
Non-controlling interests	9,161	8,391	8,776	9,077	10,417
Net Earnings Per Share	249.94	210.01	188,40	182.03	223.55
Net Profit Per ADS (1 ADS : 100 Common Shares)	24,994	21,001	18,840	18.203	22,355

Statement of Financial Position (Balance Sheet) Consolidation (In Millions IDR)	2021	2020	2019	2018	2017
Assets	277,184	246,943	221,208	206,196	198,484
Liabilities	131,785	126,054	103,958	88,893	86,354
equity Attributable To owners of The Parent Entity	121,646	102,527	99,561	98,910	92,713

Contemporary Exploration of Social Sciences in the Post Pandemic Era - 1

Net Working Capital (Current Assets - Current Liabilities)	(7,854)	(22,590)	(16,64 7)	(2,993)	2,185
Long-Term Investments in Associates	139	192	1944	2,472	2.148

Capital Expenditure (In Million IDR)	2021	2020	2019	2018	2017
Total	30,341	29,436	36,585	33,620	33,1 56

Consolidated Financial and Operating Ratios	2021	2020	2019	2018	2017
Return On Assets %	12,2	12.0	12.5	13,1	16.5
Return On Equity %	23,3	24.5	23.5	23.0	29,2
Profit to Revenue Ratio (operating margin) %	33,2	31,9	31,3	29,7	34,3
Current Ratio %	88.6	67,3	71.5	93.5	104.8
Liability to Equity Ratio %	90.6	104.3	88.7	75.8	77.0
Liability to Asset Ratio %	47.5	51.0	47.0	43,1	43.5
Debt to Equity Ratio	0.48	0.54	0.44	0.38	0.32
Debt to EBITDA Ratio	0.91	0.91	0.80	0.74	0.55
Ratio of EBITDA to Interest Expenses	17,3	15,9	15,3	16,9	23,3

Performance Graphs

Pendapatan

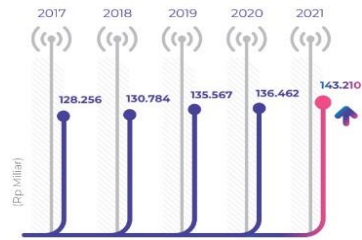

EBITDA

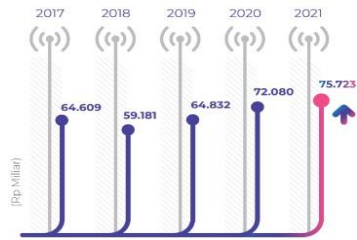

Laba Bersih

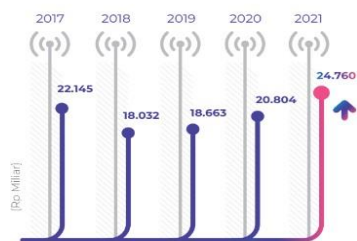

Laba Bersih per Saham

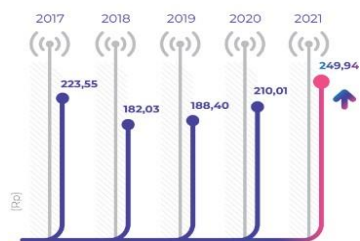

The results of PT Telkom Indonesia's financial analysis can be compared with the previous period or with similar companies in the telecommunications industry. This can provide insight into changes in performance over time and compare the company's position with its competitors.

4. CONCLUSION

Conclusion from A analysis finance on industry telecommunication like PT Telkom Indonesia maybe covers things following :

4.1 Evaluation Condition Corporate Finance : Analysis finance can give description about condition finance company And performance from time to time . Conclusion This can give outlook about ability company For endure in period long And fulfil obligation financial.

4.2 Identification Weakness And Strengths : Analysis finance can help identify weakness And strength company in matter performance finance . this _ can help management For formulate plan action And strategy more business _ ok .

4.3 Recommendation For Management Finance : Conclusion from analysis finance can lead on recommendation For management finance company , like management risk , restructuring debt , or development strategy investment .

Conclusion And Implications More Next : Conclusion from analysis finance can give implication And conclusion more carry on about condition finance company . this _ can help taker decision For make more decisions _ Good in manage company.

REFERENCES

- Afifah, FL, Saroh, S., & Zunaida, D. (2021). Analysis of Financial Statements in Measuring Company Financial Performance on the Indonesia Stock Exchange (Case Study at Pt. Unilever Indonesia, Tbk Period 2017-2019). *Jiagabi*, 10(1), 13–22.
- Amaliyah, AR, & Alie, RMM (2020). Analysis of Financial Performance in Kepanjen Uber Cooperative through Liquidity, Solvency and Profitability Ratios. *Inventory: Journal of Accounting*, 4(1), 33–40.
- Arikunto, S. (2013). *Research Procedures: A Practical Approach*. Jakarta: Rineka Cipta.
- Dewi, PYK, & Suryantini, NPS (2018). Comparative Analysis of Company Financial Performance Before and After Acquisition. *Unud Management E-Journal*, 7(5), 2323–2352.
- Efriyanti, F., Anggraini, R., & Fiscal, Y. (2012). Analysis of Financial Performance as a Basis for Investors Investing in PT. Bukit Asam, Tbk (Case Study at PT. Bukit Asam, Tbk). *Journal of Accounting and Finance*, 3(2), 299–316. <https://doi.org/10.36448/jak.v3i2.236>
- Fahmi, I. (2012). *Financial Statement Analysis*. Bandung: CV. Alfabeta.
- Fahmi, I. (2017). *Financial Statement Analysis*. Bandung: Alfabeta.
- Fuada, N., Wahyuni, W., & Darwin, K. (2020). Analysis of Financial Performance and Profit Growth of PT Semen Tonasa. *Paradox: Journal of Economics*, 3(3), 161–170.
- Hanafi, MH, & Halim, A. (2016). *Financial Statement Analysis*. Yogyakarta: UPP STIM YKPN. Hope, SS (2016). *Critical Analysis of Financial Statements*. Jakarta: PT. RajaGrafindo Persada.
- Harjito, AD, & Martono. (2013). *Financial Management (Second Edition)*. Yogyakarta: Econsia



A Counseling Teacher in Narrative Photography

Mrs. Erlina Novianti

Photography Department, Faculty of Art and Design
Universitas Trisakti, Jakarta, Indonesia
erlina@trisakti.ac.id

Ms. Syamila Tartila Sofian

Photography Department, Faculty of Art and Design
Universitas Trisakti, Jakarta, Indonesia

Mrs. Silviana Amanda Aurelia Tahalea

Photography Department, Faculty of Art and Design
Universitas Trisakti, Jakarta, Indonesia
Silviana@trisakti.ac.id

Mrs. Asih Resto Dewanti

Photography Department, Faculty of Art and Design
Universitas Trisakti, Jakarta, Indonesia
Asihretno@trisakti.ac.id

ABSTRACT

School is the second form of education after the family. However, sometimes certain interactions can negatively impact students' mental health during their academic journey in schools. Consequently, schools employ teachers who are responsible for addressing such cases, namely counseling teachers (Indonesian: Guru Bimbingan dan Konseling [BK]). Risa Savitri is one such individual entrusted with the role of a counseling teacher. She works at junior high school 8 Sukabumi city, which is the first public school that caters to children with special needs. In her capacity, Risa Savitri assists both students with special needs and those encountering various issues. In this context, the authors focus on Risa Savitri as the central subject in narrative photographs. Narrative photos are a series of visuals that depict the harmony of a story. One crucial aspect of narrative photography is that it presents a theme and describes a specific situation. The composition of narrative photos follows a specific structure, which includes opening, main, and closing shots. To capture these photos effectively, authors employ the technique of utilizing nine elements: overall shots, medium shots, detailed shots, portrait shots, shots capturing interactions, shots with a signature, sequence shots, clincher shots, and shots with context. These elements aid in producing a series of narrative photos while utilizing available light, adhering to the principles of photojournalism that prioritize authenticity and avoid manipulation. The research methodology employed in this study was practice-based research, involving observations and a comprehensive review of relevant literature. The primary objective of this study was to portray and document the activities of a counseling teacher.

Keywords: Counselling Teacher, Documentation Photos, Narrative Photography

INTRODUCTION

The school serves as the second educational institution for teenagers after their family environment. However, the interactions that students engage in during their schooling often lead to negative effects on their mental well-being. At the junior high school level, students are typically aged 12 to 15, which falls within the category of teenagers (Rizkyta & Fardana, 2019:2). To address this, schools employ counseling teachers (Indonesian: Guru Bimbingan dan Konseling [BK]), who have the responsibility of providing guidance and counseling to students (Hayati : 2016). They play a crucial role in assisting students in achieving self-understanding and developing the necessary skills to adapt effectively within the family, school, and community settings. Students have the right to receive guidance from these teachers (Hayati, 2016:603). Counseling is an essential activity and aims to facilitate positive changes in individuals' thoughts, behavior, and attitudes and should ideally be conducted by licensed or professional counselors (Mahdi, 2017:7). As every individual is unique, some students may face learning difficulties, which require special attention and support (Lisnawaty, 2017:64). The duties of counseling teachers revolve around fostering students' self-development based on their talents, needs, personality, interests, and potential within the school context (Hayati, 2016:604). Guidance and counseling are essential supporting services provided to individuals or groups of students, helping them navigate their daily lives independently, develop to their full potential, and overcome the challenges they encounter (Ramlah, 2018:71). One exemplary counseling teacher who carries out these responsibilities is Risa Savitri.

Risa Savitri is a counseling teacher at the junior high school (Indonesian: Sekolah Menengah Pertama [SMP]) level. She holds a teaching degree and has also undergone assessor training for individuals with mental disabilities (also known as people with special needs). Currently, Risa is assigned to junior high school 8 Sukabumi city, which is the first public school in the area to accommodate students with these special needs. The school provides special classes and dedicated guidance and counseling rooms for the education and support of students with special needs. Risa's role as a counseling teacher, along with her work in assisting students with special needs, presents an intriguing opportunity to explore through a photographic narrative approach. Narrative photos, consisting of a series of images, can be utilized to visually convey the coherence of a story. Narrative photos, in particular, feature a thematic focus and depict specific situations. The composition of narrative photos typically follows a fixed structure comprising an opening, main, and closing sequences (Kuswihatmo, 2016:6). The creation of the photographic work employs various techniques, including the utilization of nine elements of narrative photos, namely clincher shots, detailed shots, shots capturing interactions, shots with context, overall shots, medium shots, portrait shots, sequence shots, and shots with a signature. These elements serve to visually highlight the main subject, objects, techniques, perspectives, and moods in the photographs (Wijaya, 2016:47-49). Natural lighting, specifically sunlight, was utilized for this project as the shooting process aimed to capture spontaneous moments without any artificial manipulation.



METHODS

The method employed in this study was practice-based research. It involves initiating the research process through practical work and application. This type of research is particularly suitable for designers, as it allows for the direct application of new knowledge gained from the research to the relevant field. Researchers make use of their skills and existing knowledge in the subject matter to the best of their abilities. Specific methods utilized in practice-based research include various approaches to information gathering. For instance, these may involve creating artworks, engaging in observations and drawings in all forms, maintaining sketchbooks or notes, using notations and specific symbols, developing models, conducting material experiments, mapping concepts or diagrams, employing metaphors and analogies, utilizing glossaries, and building visual and textual archives. These methods can also be integrated with social science methodologies, often adapted in different ways, such as through case studies and observation (Nuning, 2015: 26). In the context of this research, the outcomes were photographic works, specifically narrative photographs that highlighted the role of Risa as a counseling teacher. Data collection was conducted through observations to gather the necessary information.

RESULTS AND DISCUSSION

In this study, the approach utilized for producing photographic works involves employing various narrative photographic techniques. Story photography is a component of photojournalism that can effectively convey powerful messages, evoke new emotions, generate excitement, and stimulate discussions. The presentation of narrative photos goes beyond a single photograph and entails creating a series of photos that collectively construct a narrative, accompanied by text that provides explanations of the depicted situations, events, or backgrounds. The World Press Photo, the organizer of a renowned photojournalism competition, stipulates that narrative photographic works must consist of a minimum of two photos and a maximum of twelve photos (Wijaya, 2016 : 14).

Within a narrative photographic work, several elements contribute to its composition, including:

1. Overall Shots

Overall shots capture a wide perspective of the scene, providing an encompassing view of the location. These shots are typically used as opening photos to set the atmosphere and context of the story.

2. Medium Shots

Medium shots focus on individuals or groups, narrowing the scope of the story. They help to establish a closer connection between the viewers and the subjects in the narrative.

3. Detailed Shots

Detailed shots involve capturing close-up images that highlight specific elements or important parts of the story. These shots serve as focal points within the series, compelling the viewers to pause and observe.

4. Portrait Shots

Portrait shots feature the main characters or individuals in the story. They can be taken

during significant moments, showcasing the subject's face, body, and relationship with the environment.

5. Shots Capturing Interactions

Shots capturing interactions showcase the relationships and exchanges between characters and their environment, encompassing physical, emotional, and professional interactions.

6. Shots with a Signature

Shots with a signature represent the key or defining moments within the series of narrative photos. They encapsulate the essence or summary of the narrative.

7. Sequence Shots

Sequence shots consist of multiple photos depicting a step-by-step progression or a sequential action. They showcase the subject's systematic approach or illustrate a process.

8. Clincher Shots

The clincher is the final photo in the series or the concluding image that wraps up the narrative, leaving a lasting impression on the viewers.

9. Shots with Context

These shots are strategically incorporated by the photographer to evoke the reader's imagination based on their experiences, insights, culture, and values. These photos maintain relevance and enhance the overall meaning of each series of narrative photographic works (Wijaya, 2016 : 51-59).

Story photography encompass various categories, one of which is narrative photos. These photos depict specific themes and describe situations or structures (Wijaya, 2014: 76). According to (Kuswihatmo, 2016:6)narrative photos possess distinct characteristics, including a narrative structure in which the series of photos comprising the story—namely, the opening, main, and closing shots—cannot be altered. The opening photo introduces significant characters, guiding the reader into the story (Wijaya, 2016:39-40). The main section explores the ideas, emotions, and experiences conveyed by the author, presenting a deeper narrative around the main subject. This section includes conflict interactions, detailed observations, and contextual information to enhance the reader's understanding (Wijaya, 2016 : 42). The closing of the narrative photographic works must leave a lasting impression and can serve as the conclusion to the entire narrative (Wijaya, 2016 : 44).

This study aims to create 10 narrative photos that portray the life and role of Risa Savitri, a counseling teacher at junior high school 8 Sukabumi city using nine elements photo story. Risa Savitri serves as the main subject in these photographs, showcasing her duties and responsibilities. The resulting photo series is as follows:

1. Junior High School 8 Sukabumi City



Figure 1. **Junior High School 8 Sukabumi City**
(Source: Syamila Tartila Sofian)

This first photo serves as the opening in the resulting narrative photo series. It presenting the front view of junior high school 8 Sukabumi city building. The authors aim to provide information about the shooting location through this photo, which is supported by the text displayed on the front of the school. The element used is the overall shot to capture a wide view and convey the atmosphere of the shooting location. The location depicted in the photo is junior high school 8 Sukabumi city, where Risa Savitri, the counseling teacher and the main subject of the narrative photographs, works. The authors chose a low angle to emphasize the dominant presence of the building, which also serves as the opening photo, allowing viewers to immediately grasp the location information. A long shot format is employed to presenting the opening location. Furthermore, the lighting utilized is natural light from the sun, as the shooting took place outdoors. The following are the technical details for this photo:

Table 1. Technical Information of Figure 1

No.	Technical Information	
1	Photoshoot location	Junior high school 8 Sukabumi city
2	Year of Shooting	2019
3	ISO	100
4	Aperture	F/9
5	Shutter Speed	1/250

2. Risa Savitri: A Counseling Teacher



Figure 2. **Risa Savitri: A Counseling Teacher**
(Source: Syamila Tartila Sofian)

In this second photo, we see Risa Savitri, who is a counseling teacher. Risa has been dedicated to her role as a counseling teacher at junior high school 8 Sukabumi city for approximately 15 years. The photo captures Risa actively engaged in her work at her desk, in front of a laptop. The composition of the photo allows us to see Risa's face and character, along with the books and stationery on her desk that provide additional context. The element used is the portrait shot to highlight the main subject (Risa Savitri) and convey information about her. This technique is employed during significant moments, capturing the main subject alone to ensure her clear visibility in the photo. This photo captures an important moment in which the main subject is shown working in a room, surrounded by a laptop and stacks of books. The half-body portrait composition is chosen to ensure a clear view of the main subject for the spectators. The photo is captured using a medium shot format, allowing the viewers to observe the subject's surroundings. The angle chosen for this photo is at eye level, creating a true-to-life representation of the scene. Natural lighting from the window is utilized in this photo, resulting in uneven but graded lighting that adds a dramatic impression to the image. The following are the technical details for this photo:

Table 2. Technical Information of Figure 2

No.	Technical Information	
1	Photoshoot location	Junior high school 8 Sukabumi city
2	Year of Shooting	2019
3	ISO	800
4	Aperture	F/4
5	Shutter Speed	1/200

3. Counseling



Figure 3. Counseling
(Source: Syamila Tartila Sofian)

This third photo showcases one of the duties and responsibilities of the main subject, the counseling teacher, which involves conducting counseling sessions for students who have violated school rules. The element utilized in this photo is the medium shot. The medium shot is employed to narrow down the narrative photographic series and bring the subject closer to the reader. In this photo with the medium shot, the main foreground subject is

depicted actively providing counseling to students. The format used in the photo is a medium shot, which captures both the main subject in the foreground and the background where students who violated school rules are present. The students can be seen with serious expressions, attentively listening to the lecture, and their eye contact directs towards the main subject. In general, the photo provides information to the viewers about Risa Savitri's duties and responsibilities. The photo is captured from an eye-level angle, which gives it a natural and authentic appearance. The photo is illuminated using available lighting, resulting in a bright and clear depiction of the subject and the conveyed information. The following are the technical details for this photo:

Table 3. Technical Information of Figure 3

No.	Technical Information	
1	Photoshoot location	Junior high school 8 Sukabumi city
2	Year of Shooting	2019
3	ISO	800
4	Aperture	F/3.5
5	Shutter Speed	1/400

4. Calling A Student



Figure 3. **Calling A Student**
(Source: Syamila Tartila Sofian)

In this third photo, we continue with the next part of the narrative photographic series. The photo showcases additional duties and responsibilities that form part of Risa Savitri's daily activities. In this photo, Risa is seen in the classroom, calling out to one of the students with special needs who are under her guidance. The photo exemplifies the element of

sequences, as it captures the sequential activities performed by the subject in the photo. This element is medium, utilized to highlight the focus on students with special needs who require specialized guidance from the main subject. The photo is captured using a medium shot format and features a foreground consisting of the main subject in a classroom at Junior high school 8 Sukabumi city, surrounded by students. The photo is taken from an eye-level angle, providing a realistic depiction of the scene. Natural lighting from the window is used in this photo, creating a nuanced and uneven lighting effect. Despite the variations in lighting, the main subject is still clearly visible and recognizable in the visual composition. The following are the technical details for this photo:

Table 4. Technical Information of Figure 4

No.	Technical Information	
1	Photoshoot location	Junior high school 8 Sukabumi city
2	Year of Shooting	2019
3	ISO	800
4	Aperture	F/3.5
5	Shutter Speed	1/320

5. Heading to the Study Room



Figure 5. Heading to the Study Room
(Source: Syamila Tartila Sofian)

The photo is a continuation of the previous narrative photo sequence. Following the scene where Risa Savitri called a student with special needs in the previous photo, this photo captures the moment when both the student and the counseling teacher, Risa Savitri, are walking toward the special counseling room. The photo shows the student and the teacher descending the stairs on their way to the room. The photo is captured in a medium shot

format, allowing a direct focus on the subject. The angle used in this photo is a high angle, chosen to showcase the process of students and teachers walking down the stairs leading to the room. The photo is captured using available lighting, utilizing natural sunlight. This lighting technique creates a contrasting effect, resulting in a photo that showcases both dark and bright areas, enhancing the visual depth and dimensions of the image. The following are the technical details for this photo:

Table 5. Technical Information of Figure 5

No.	Technical Information	
1	Photoshoot location	Junior high school 8 Sukabumi city
2	Year of Shooting	2019
3	ISO	800
4	Aperture	F/3.5
5	Shutter Speed	1/320

6. Guiding a Student with Special Needs



Figure 6. **Interaction**
(Source: Syamila Tartila Sofian)

This photo depicts Risa Savitri engaging in the task of guiding a student with special needs during his computer-based exams. Risa Savitri appears patient and dedicated to teaching the student how to use a computer. Risa Savitri's patience is evident from the expression on her face, and the student's expressions also reflect his comfort during the guidance

process with Risa Savitri. The photo also uses a signature story element which is the defining moment, showing Risa as a tutor for students with special needs. Apart from that, the photo is captured in a medium shot format, allowing the surrounding atmosphere to be depicted and emphasizing a row of computers, which enhances the photo's impact. The photo is taken from an eye-level angle to present a natural and authentic depiction of the scene. Furthermore, available lighting is used to maintain the spontaneous and undisturbed atmosphere during the photo capture. The following are the technical details for this photo:

Table 6. Technical Information of Figure 6

No.	Technical Information	
1	Photoshoot location	Junior high school 8 Sukabumi city
2	Year of Shooting	2019
3	ISO	800
4	Aperture	F/4
5	Shutter Speed	1/125

7. Guiding with Patience

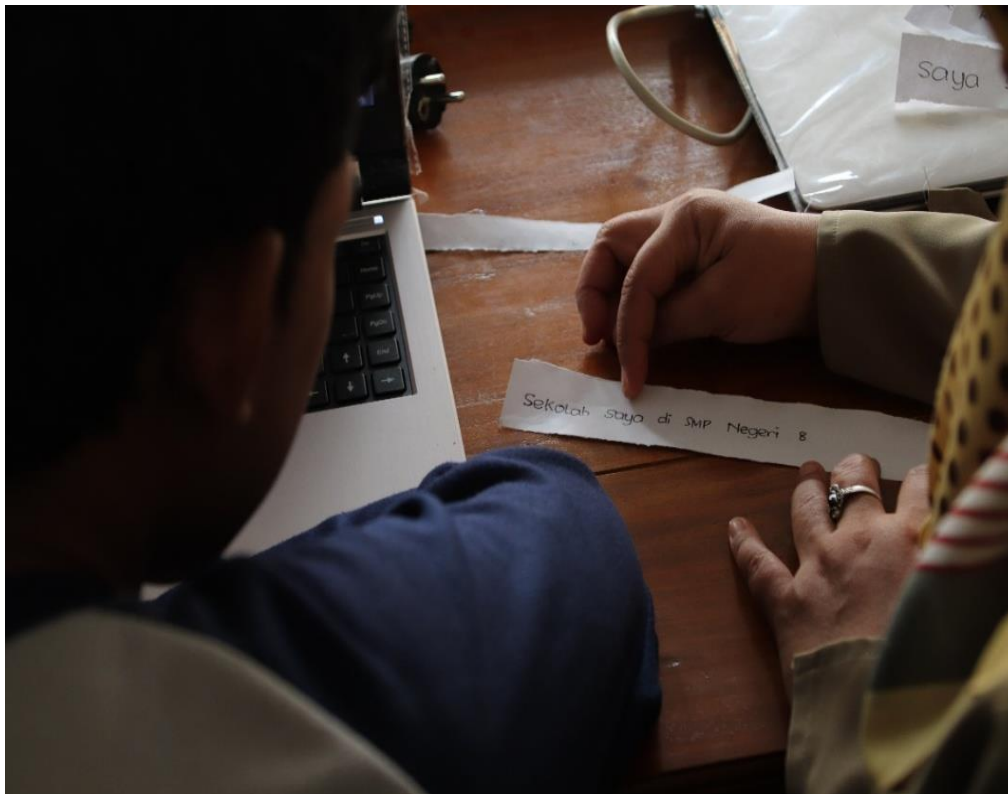

Figure 7. Guiding with Patience
(Source: Syamila Tartila Sofian)

The photo captures one of Risa Savitri's activities in patiently teaching students with special needs how to read. It is evident from Risa's efforts in creating specific instructions

on a piece of paper, which needs to be entered into the computer during the exam. Risa is also seen guiding the students in reading the writing, as depicted by the subject's finger pointing to each word on the paper. The writing on the paper is legible, which reinforces the information conveyed in the photo. The photo utilizes the detailed shot as a narrative element, capturing a close-up view of the subject's hand and the written text on the paper. Furthermore, the medium close-up format allows for a focused depiction of these specific details. The authors also highlight significant parts that serve as the main focal points, captivating the spectators' attention and enticing them to closely observe the narrative photo series being depicted. The angle chosen for this photo is high, as it effectively showcases the detailed visual elements and allows for clear visibility of the ongoing activities, including the text on the paper. This perspective offers a comprehensive view, ensuring that the depicted scene and its accompanying details are easily discernible to the viewers. The lighting employed in this photo is available lighting, which imparts a contrast of light and shadow, creating a visually captivating effect. The following are the technical details for this photo:

Table 7. Technical Information of Figure 7

No.	Technical Information	
1	Photoshoot location	Junior high school 8 Sukabumi city
2	Year of Shooting	2019
3	ISO	800
4	Aperture	F/4.5
5	Shutter Speed	1/80

8. Guiding Sincerely



Figure 8. Guiding Sincerely
(Source: Syamila Tartila Sofian)

The photo captures Risa Savitri's genuine dedication to guiding a student with special needs. It exemplifies the patience and sincerity required to assist the student effectively. Risa's expression portrays her unwavering patience, sincerity, and constant smile as she teaches him to type using a computer. In the photo, the student is depicted as being fully focused and determined while typing, using their index finger to carefully press each key. The chosen narrative element for this photo is interaction, as it aims to portray the dynamic interaction between the individuals involved. The photo is captured in a medium shot format, allowing for a clear depiction of the interactions between the individuals involved. The composition of the photo includes a foreground featuring a student with special needs, while the main subject is situated in the background. The foreground and background in the photo work together harmoniously, enhancing the overall composition. Natural lighting from sunlight entering the room is also utilized, adding a warm and authentic ambiance to the photo. The following are the technical details for this photo:

Table 8. Technical Information of Figure 8

No.	Technical Information	
1	Photoshoot location	Junior high school 8 Sukabumi city
2	Year of Shooting	2019
3	ISO	400
4	Aperture	F/3.2
5	Shutter Speed	1/60

9. A Home Visit



Figure 9. A Home Visit
(Source: Syamila Tartila Sofian)



The photo depicts the duties and responsibilities of Risa Savitri, a counseling teacher. In addition to guiding students in the classroom, Risa also conducts home visits to gather information about students who are absent from school. This activity is regularly carried out by Risa to document students who require guidance. The photo captures Risa engaging in a question-and-answer session with the parents of the students, while diligently taking notes in her book based on the information she receives. The chosen narrative element for this photo is medium, allowing it to showcase not only the ongoing activity but also the ambiance of the visited house. Furthermore, regarding the angle, the photo is taken at eye level, providing a natural and realistic perspective for the spectators. The lighting in the photo is achieved through available light, specifically sunlight that enters the house. The following are the technical details for this photo:

Table 9. Technical Information of Photo 9

No.	Technical Information	
1	Photoshoot location	SMPN 8 Kota Sukabumi
2	Year of Shooting	2019
3	ISO	6400
4	Aperture	F/3.5
5	Shutter Speed	1/50

10. The Day Is Over



Figure 10. **The Day Is Over**
(Source: Syamila Tartila Sofian)

This is the final photo in the narrative photographic series. It captures the conclusion of Risa Savitri's activities as a counseling teacher. In the photo, Risa is depicted riding her

motorcycle, symbolizing the end of her duties and responsibilities for the day as she heads home. The photo uses the clincher shot, depicting the final moment in the series as the conclusion. The main subject, Risa Savitri, is shown from behind, but her face is visible in the rearview mirror, allowing the spectators to recognize her. Furthermore, the photo incorporates a shot with context, allowing the spectators to engage their imagination and create their respective interpretations to conclude the story. Regarding the angle, the photo is captured by a medium shot, enabling a clear view of the main subject and its surrounding environment. The lighting utilized is natural sunlight (available lighting), providing authentic illumination to the scene. The following are the technical details for this photo:

Table 10. Technical Information of Photo 10

No.	Technical Information	
1	Photoshoot location	SMPN 8 Kota Sukabumi
2	Year of Shooting	2019
3	ISO	200
4	Aperture	F/5
5	Shutter Speed	1/640

CONCLUSION

Storytelling photos are a series of images used to convey a complete story. When presenting a storytelling story, the narrative approach can be employed. In this study, the authors created a series of 10 narrative photographs featuring Risa Savitri, a counseling teacher at SMP Negeri 8 Kota Sukabumi. The study incorporates various story photo elements, including overall shots, medium shots, detailed shots, portrait shots, shots capturing interactions, shots with a signature, sequence shots, clincher shots, and shots with context. By opting for the presentation of photo stories, the resulting photos become more organized and well-arranged. The utilization of story photo elements further aids in producing cohesive photo works that effectively support storytelling. Each element serves a specific function in capturing a particular moment, and when combined in a series of 10 photos, they create a coherent and comprehensible storyline. The flow and content of a well-crafted narrative photographic series facilitate the spectators' comprehension and understanding of the story intended to deliver. In this study, available lighting, specifically sunlight, is utilized to capture spontaneous shots on location while minimizing any disruptions to the subject caused by artificial lighting effects.

SUGGESTION

When producing a narrative photographic series, it is crucial to understand and select the appropriate presentation style. This allows the authors to organize the stories in a structured manner and effectively communicate visual narratives that are not only visually appealing but also convey essential information and maintain the integrity of the story. By carefully curating the sequence and arrangement of the photos, the authors can ensure that the story is conveyed accurately and engagingly, leaving a lasting impact on the viewers.

REFERENCES

Guru Bimbingan, P., Konseling, D., Meningkatkan, D., Belajar, K., Di, S., Negeri, S., Sleman, D., & Mahdi, Y. (n.d.). *Mahdi: Peran Guru Bimbingan dan Konseling dalam Meningkatkan... / 1*. *Jurnal Psikologi Pendidikan dan Perkembangan*. (n.d.). <http://url.unair.ac.id/5e974d38>



- Lisnawaty, R. (n.d.). *PENGLOLAAN BIMBINGAN KONSELING DI SEKOLAH MENENGAH PERTAMA*.
- Magdalena Nuning, M. W. (n.d.). *METODE PENCIPTAAN BIDANG SENI RUPA: Praktek Berbasis Penelitian (practice based risearch), Karya Seni Sebagai Produksi Pengetahuan dan Wacana*.
- Negeri, M. A., Bengkulu, K., & Fatmawati, J. B. (n.d.). *PERAN GURU BIMBINGAN DAN KONSELING DALAM MENGATASI KECENDERUNGAN PERILAKU AGRESIF PESERTA DIDIK DI MA Fitri Hayati*.
- Oleh. (n.d.). *JURNAL BENCANA ASAP DALAM ESAI FOTO (Studi Analisis Semiotika terhadap Makna Dampak Bencana Asap dalam Esai Foto Jurnalistik "Riau Lautan Asap" dalam Majalah National Geographic Indonesia edisi September 2015)*. http://sipongi.menlhk.go.id/hotspot/luas_kebakaran,
- PENTINGNYA LAYANAN BIMBINGAN KONSELING BAGI PESERTA DIDIK (The Importance Of Counting Country Services For Students)*. (n.d.).
- Wijaya, T. (2016). *Photo Story Handbook: Panduan Membuat Foto cerita* (1st ed.). Gramedia.

**Accounting Inquiries with New Approaches in the Post-Pandemic Era
Volume I**

Digital Transformation Impact on Financial Performance of Telecommunication Industry in Indonesia during and after Pandemic Covid-19

Feby SALLYANTO

Sekolah Tinggi Manajemen IPMI

feby.sallyanto@ipmi.ac.id

Orcid: 0009-0006-6540-0939

Wiwiek Mardawiyah DARYANTO

Sekolah Tinggi Manajemen IPMI

wiwiek.daryanto@ipmi.ac.id

Orcid: 0000-0003-3582-5857

ABSTRACT

Digital Transformation was inevitable amongst many industry in Indonesia driven by the exponential increase of customers, transaction, and traffic which leads the companies do more automation and developed on-premise as well as on-cloud data and systems. It was also pushed faster by the rapid application development and vast networks with higher bandwidth. The adoption on Digital was exceedingly explode due to Pandemic Covid-19 which forced customers and companies to keep the distance and rely very much on device, application, and networks. The Telecommunication Companies in Indonesia surely need to enlarge the capacity multiple times and adding more core and platforms to serve the increase. This research aims to analyze the financial impact on Digital Transformation acceleration in Industries during and after Pandemic Covid-19 on the two dominant Telecommunication Companies in Indonesia, PT. Telkom Indonesia and PT. XL Axiata. The Decree No. KEP 100/MBU/2002 issued by Ministry of State-Owned Enterprise (SOE) in June provides the mandatory of measuring and rating of the SOE financial health condition. The financial ratios investigated were : (1) Return On Equity, (2) Return On Invesment, (3) Cash Ratio, (4) Current Ratio, (5) Total Asset Turn Over, and (6) Equity to Total Asset Ratio then be validated by the said Ministry of SOE Decree to conclude yearly financial health condition on both companies. The result shows that from 2019 – 2022, both companies have achieved relatively financial healthy condition levels and ratings as follows ; PT. Telkom Indonesia (AA, AA, AA, AA) and PT XL Axiata (B,B,B,B) respectively comparing with the SOE Decree standard. This study gives a strong insight for regulator, investors, company leaders, and customers on the survivability and sustainability of Telecommunication Business.

Keywords: Digital Transformation, Telecommunication Industry, Financial Health, Profitability, During & After Pandemic Covid-19, Telkom Indonesia, XL. Axiata

INTRODUCTION

During the Covid-19 pandemic, the virtual world has become much busier than ever before. This has happened as a result of more and more people having turned to use their gadgets and computers as a means of survival in order to substitute various in-person activities. These changes in society have had an impact on economic development by accelerating its digital transformation. There were many discussions, conferences, surveys, and articles from high profile organizations, lectures in universities, and professionals cited the adoption of digitalization during Pandemic Covid 19. To mention some of them are surveys did by MC Kinsey in October 2020 on How Covid-19 has pushed companies over the technology tipping point and transformed business forever. Also the lecture delivered by Prof. Sri Adiningsih, M.Sc., Ph.D. from Faculty of Economics and Business UGM, on the "Covid-19 Impact on Digital Economy : Indonesian Case" in July 2021 as part of International Week (IWEK 2021) virtual summer program. As well as the study done by European Parliament's Committee on in September 2022 which looking at the Digitalisation and changes in the world of work.

According to McKinsey Global Survey of executives, the companies have accelerated the digitization of their customer and supply-chain interactions and of their internal operations by three to four years. And the share of digital or digitally enabled products in their portfolios has accelerated by a shocking seven years. Nearly all respondents on their survey say that their companies have stood up at least temporary solutions to meet many of the new demands on them, and much more quickly than they had thought possible before the crisis. When Mc Kinsey asked executives about the impact of the crisis on a range of measures, the executives say that funding for digital initiatives has increased more than anything else --- more than increases in costs, the number of people in technology roles, and the number of customers. Digital adoption has taken a quantum leap at both organizational and industries.

The COVID-19 crisis has accelerated the digitization of customer interactions by several years.

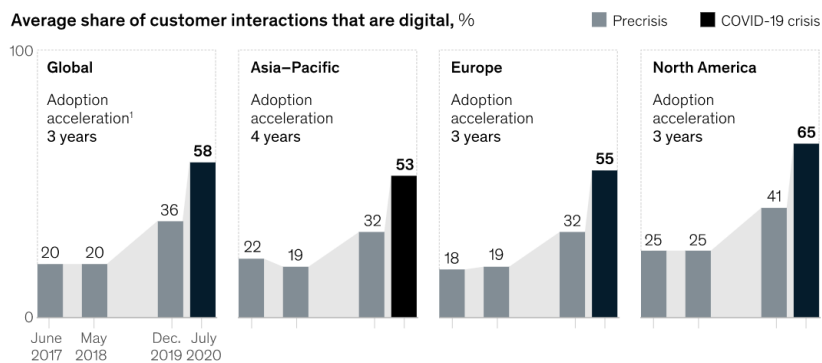

*Years ahead of the average rate of adoption from 2017 to 2019.

McKinsey
& Company

Prof. Sri Adiningsih from UGM cited that Pandemic Covid-19 had increased unemployment and poverty rates in Indonesia. However, when the pandemic hit, the digital transformation was developed and even disrupted business and economy. First, the drive to



reduce in-person interactions during the Covid-19 pandemic has prioritized digitalization and automation. Second, since the onset of the pandemic, digitalization and automation have been sought to be accelerated, partly because their adoption helps reduce the need for physical contact. The pandemic has also led to a further acceleration of digital transformation globally. She also added, which is an increase in micro firms and firms in the manufacturing sector that have adopted the use of digital platforms by 59% since October 2020. According to her, Covid-19 has prompted consumer and business behaviour shifts. There were 4 sectors that was in high demand in the post-Covid era, namely the Education sector whose access is increasingly widespread thanks to online learning innovations, the Healthcare sector which continues to develop with technological developments, the Fintech sector where digital lending and online investment are gaining momentum, and the e-Commerce sector where the number of online shoppers has surged in this pandemic era. She concluded that the transformation of the digital economy has grown rapidly in the last decade and the pandemic has accelerated the process.

The Covid-19 pandemic has brought with it an explosion in demand for remote and platform work and has accelerated the digital transformation of many regular workplaces. Digitalisation in the workplace covers a variety of digital technologies and fast-developing applications, ranging from digital communication and information tools (ICT) to the combination of robots and Artificial Intelligence (AI) as what European Parliament's Committee cited in September 2022.

However, none of the above stated clearly what were the impact on the business and financial performance on the business sectors. For example, it was probably still too early for Mc Kinsey surveys in 2020 to predict since Covid-19 Pandemic was not known when it will be finished. Year 2020 when Mc Kinsey did the survey was on the midst of the first wave Covid-19 "Alpha", before 2nd wave "Delta" and 3rd "Omicron", and so the performance as of during and after Pandemic still could not be measured or predicted. The presentation delivered by Prof Adiningsih from UGM also had not state whether the digital adoption on some sectors including but not limited to Education, Healthcare, Fintech, E-Comm, and Telcos are giving a stronger performance to their financials. It remains unclear whether the big wave of digital adoptions, which forced customers and companies to keep the distance and rely very much on online, automation, and cloud using the device, application, and networks could be the win fall or otherwise the down fall for the Telecommunication Industry (Telcos) which must positioned in two main roles ; as the digitalisation adopters as well as digitalisation enablers for other industries.

We understand that the digitalisation adoption had forced Telcos to enlarge the capacity and upgrade or add cores and platforms to serve their own business needs. Furthermore, the Telcos need to add capacity to serve the other businesses (their customers) which undergo digitalisation adoption as well. So this study is measuring the impact of digitalisation acceleration on the financial performance of Telecommunication Industry during and after

Covid-19 Pandemic. This research aims to analyze the financial impact on Digital Transformation acceleration in Industries during and after Pandemic Covid-19 on the two dominant Telecommunication Companies in Indonesia, PT. Telkom Indonesia and PT. XL Axiata referring to the Decree No. KEP 100/MBU/2002 issued by Ministry of State-Owned Enterprise (SOE) in June provides the mandatory of measuring and rating of the SOE financial health condition.

The financial reports on early Covid-19 Pandemic showed an incremental number of traffic due to discussion, reporting, data exchange and transaction that most of people do thru a connectivity channel. Cellular companies like Telkomsel (subsidiary of PT. Telkom) and XL Axiata might had a significant increase of traffic. Was it sustain? Was the margin increased? Did the additional capital spending or operational expense had a good return? Did the collection from customers under pressure? The quantitative research is conducted according to the following chapters :

1. How the internal traffic and external traffic impacting the additional capital, operational expense, and the revenue
2. How the key financial ratio result during and after Covid-19 Pandemic
3. Conclusion

LITERATURE REVIEW

1. Digital Transformation

Digital transformation is the process by which companies embed technologies across their businesses to drive fundamental change. The benefits? Increased efficiency, greater business agility and, ultimately, the unlocking of new value for employees, customers and shareholders. Many different paths lead to digital transformation and each organization's journey will be unique. For example, a company might introduce AI or cloud computing to enhance its customer experience. Or it might redesign its supply chain to make better use of machine learning. A company can even make spot-on predictions about the products customers will want in a few months' time, then shift production to meet demand.

Two concepts related to digital transformation are *digitization* and *digitalization*. Digitization is the process of translating analog information and data into digital form—for example, scanning a photo or document and storing it on a computer.

Digitalization is the use of digital technologies to change business processes and projects—such as skilling employees to use new software platforms designed to help launch products faster.

While digital transformation might include digitalization efforts, it goes beyond the project level and affects the entire organization. For most companies, digital transformation requires a shift away from traditional thinking and toward a more collaborative, experimental approach. These new ways of approaching work reveal new solutions which, in turn, can improve customer experience, drive employee innovation and spur company growth at the fundamental level (<https://www.accenture.com/us-en/insights/digital-transformation>)

2. Telecommunication industry



The telecommunications industries within the sector of information and communication technology is made up of all telecommunications/telephone companies and internet service providers and plays a crucial role in the evolution of mobile communications and the information society (https://en.wikipedia.org/wiki/Telecommunications_industry)

Traditional telephone calls continue to be the industry's biggest revenue generator, but thanks to advances in network technology, telecom today is less about voice and increasingly about text (messaging, email) and images (e.g. video streaming). High-speed internet access for computer-based data applications such as broadband information services and interactive entertainment is pervasive. Digital subscriber line (DSL) is the main broadband telecom technology. The fastest growth comes from (value-added) services delivered over mobile networks ("*The Industry Handbook: The Telecommunications Industry*". 7 January 2004).

The telecom sector continues to be at the epicenter for growth, innovation, and disruption for virtually any industry. Mobile devices and related broadband connectivity continue to be more and more embedded in the fabric of society today and they are key in driving the momentum around some key trends such as video streaming, Internet of Things (IoT), and mobile payments ("*2017 Telecommunications Industry Outlook - Deloitte US*". *Deloitte United States*).

3. *Financial Statement and Financial Health*

Financial statements are a collection of summary-level reports about an organization's financial results, financial position, and cash flows. They include the income statement, balance sheet, and statement cash of flows (<https://www.accountingtools.com/articles/financial-statements>)

Financial health is a state that refers to a person's or a firm's finances in terms of expenses, savings, and debt. It assesses one's ability to balance or manage their financial needs and wants. It can be either good or bad. However, a bad financial condition can cause stress and debt issues. Therefore, businesses use financial health ratios to determine soundness. The financial health indicator includes solvency, debt, income expense, and liquidity ratios (<https://www.wallstreetmojo.com/financial-health/>).

To accurately evaluate the financial health and long-term sustainability of a company, several financial metrics must be considered in tandem. The four main areas of financial health that should be examined are liquidity, solvency, profitability, and operating efficiency. However, of the four, perhaps the best measurement of a company's health is the level of its profitability (<https://www.investopedia.com/articles/investing/061916/what-best-measure-companys-financial-health>)

4. The Decree No. KEP 100/MBU/2002

The Decree No. KEP 100/MBU/2002 was issued by Indonesia Ministry of State-Owned Enterprise (SOE) in June 2002 provides the mandatory of measuring and rating of the SOE financial health condition. It gives a standard on financial, operational, and

administration aspect for SOE which might also be used by non SOE companies. On the financial aspect, there are 8 major indicators to determine the company are Healthy, Less Healthy, or Not Healthy. The indicators are Return On Equity, Return On Investment, Cash Ratio, Current Ratio, Collection Period, Inventory Turn Over, Total Asset Turn Over, and Equity to Total Asset Ratio.

The financial health divided into 3 categories :

Healthy	AAA	Total score >95	Less Healthy	BBB	Total score 50<TS<=65
	AA	Total score 80<TS<=95		BB	Total score 40<TS<=50
	A	Total score 65<TS<=80		B	Total score 30<TS<=40
Not Healthy	CCC	Total score 20<TS<=30			
	CC	Total score 10<TS<=20			
	C	Total score <10			

METHODOLOGY

The methodology used in this research is quantitative and the data used for this study were collected from Annual Report of PT. Telkom Indonesia Tbk and PT. XL Axiata Tbk from the year 2018 to 2021. We use Financial Ratio Analysis with a combination of the Decree No. KEP 100/MBU/2002 issued by Ministry of State Own Company (SOE). We took six financial ratios as below :

Return On Equity

Return on Equity (ROE) is the measure of a company's annual return (net income) divided by the value of its total shareholders' equity. Return on Equity is a two-part ratio in its derivation because it brings together the income statement and the balance sheet, where net income or profit is compared to the shareholders' equity. The number represents the total return on equity capital and shows the firm's ability to turn equity investments into profits. To put it another way, it measures the profits made for each dollar from shareholders' equity.

$$X1 = \text{Net Income} / \text{Shareholder Equity}$$

(1) Return On Investment

Return on investment (ROI) is a financial ratio used to calculate the benefit an investor will receive in relation to their investment cost. It is most commonly measured as net income divided by the original capital cost of the investment. The higher the ratio, the greater the benefit earned.

$$X2 = \text{Net Income} / \text{Long term Liability} + \text{Shareholder Equity}$$

(2) Cash Ratio

The cash ratio is a liquidity measure that shows a company's ability to cover its short-term obligations using only cash and cash equivalents. The cash ratio is



derived by adding a company's total reserves of cash and near-cash securities and dividing that sum by its total current liabilities.

$$X3 = \text{Cash} + \text{Cash Equivalent} / \text{Short term Liability}$$

(3) Current Ratio

The current ratio measures a company's ability to pay current, or short-term, liabilities (debts and payables) with its current, or short-term, assets, such as cash, inventory, and receivables.

$$X4 = \text{Current Asset} / \text{Current Liability}$$

(4) Total Asset Turn Over

The asset turnover ratio measures the value of a company's sales or revenues relative to the value of its assets. The asset turnover ratio can be used as an indicator of the efficiency with which a company is using its assets to generate revenue.

$$X6 = \text{Sales Revenues} / \text{Total Asset}$$

(5) Equity to Total Asset Ratio

The equity to assets ratio is determined by dividing a company's total equity by its total assets. The result is expressed as a percentage, which represents the portion of the company's assets that are financed by equity.

$$X7 = \text{Total Equity} / \text{Total Asset}$$

Thereafter we put the score on each of the above ratios based on the guidance on the SOE Ministry Decree No. KEP 100/MBU/2002 as below. On this study, for Telecommunication Industry, we use the Non Infra score reference.

ROE (%)	Skor	
	Infra	Non Infra
15 < ROE	15	20
13 < ROE <= 15	13,5	18
11 < ROE <= 13	12	16
9 < ROE <= 11	10,5	14
7,9 < ROE <= 9	9	12
6,6 < ROE <= 7,9	7,5	10
5,3 < ROE <= 6,6	6	8,5
4 < ROE <= 5,3	5	7
2,5 < ROE <= 4	4	5,5
1 < ROE <= 2,5	3	4
0 < ROE <= 1	1,5	2
ROE < 0	1	0

ROI (%)	Skor	
	Infra	Non Infra
18 < ROI	10	15
15 < ROI <= 18	9	13,5
13 < ROI <= 15	8	12
12 < ROI <= 13	7	10,5
10,5 < ROI <= 12	6	9
9 < ROI <= 10,5	5	7,5
7 < ROI <= 9	4	6
5 < ROI <= 7	3,5	5
3 < ROI <= 5	3	4
1 < ROI <= 3	2,5	3
0 < ROI <= 1	2	2
ROI < 0	0	1

Cash Ratio = x (%)	Skor	
	Infra	Non Infra
x >= 35	3	5
25 <= x < 35	2,5	4
15 <= x < 25	2	3
10 <= x < 15	1,5	2
5 <= x < 10	1	1
0 <= x < 5	0	0

Current Ratio = x (%)	Skor	
	Infra	Non Infra
125 <= x	3	5
110 <= x < 125	2,5	4
100 <= x < 110	2	3
95 <= x < 100	1,5	2
90 <= x < 95	1	1
x < 90	0	0

Accounting Inquiries with New Approaches in the Post-Pandemic Era Volume I

TATO = x (%)	Perbaikan = x (%)	Skor	
		Infra	Non Infra
120 < x	20 < x	4	5
105 < x <= 120	15 < x <= 20	3,5	4,5
90 < x <= 105	10 < x <= 15	3	4
75 < x <= 90	5 < x <= 10	2,5	3,5
60 < x <= 75	0 < x <= 5	2	3
40 < x <= 60	x <= 0	1,5	2,5
20 < x <= 40	x < 0	1	2
x <= 20	x < 0	0,5	1,5

TMS thd TA (%) = x	Skor	
	Infra	Non Infra
x < 0	0	0
0 <= x < 10	2	4
10 <= x < 20	3	6
20 <= x < 30	4	7,25
30 <= x < 40	6	10
40 <= x < 50	5,5	9
50 <= x < 60	5	8,5
60 <= x < 70	4,5	8
70 <= x < 80	4,25	7,5
80 <= x < 90	4	7
90 <= x < 100	3,5	6,5

Since the calculation on this research didnt include the inventory turn over and collection period, as well as the operational and administrative score (total 40% weight according to the SOE Ministry Decree No. KEP 100/MBU/2002), then the final result will be multiplied as follow : Total Score x (100/60).

The very final score will be referred to the financial health categories as shown on the literature review point 4 to understand the financial healthy level of the companies on the Telecommunication Industry.

RESULT & DISCUSSION

The finding of this study shows that the incremental traffic for Telkom were growing significant during pandemic (2019 to 2021) above 45%, with a slightly slowdown in term of the incremental after pandemic (2021 to 2022) to a 19%. The growth of the home users, indicated by the Indihome subscriber, during the Pandemic were also increase and continued after the pandemic with the cagr 16%. The mobile users shows a fluctuation during and after pandemic but generally shows an incremental with 2% cagr. So the hikes in data traffic and home users triggering the capital expenditure increase to serve the incremental capacity and number of fixed broadband access during and after pandemic.

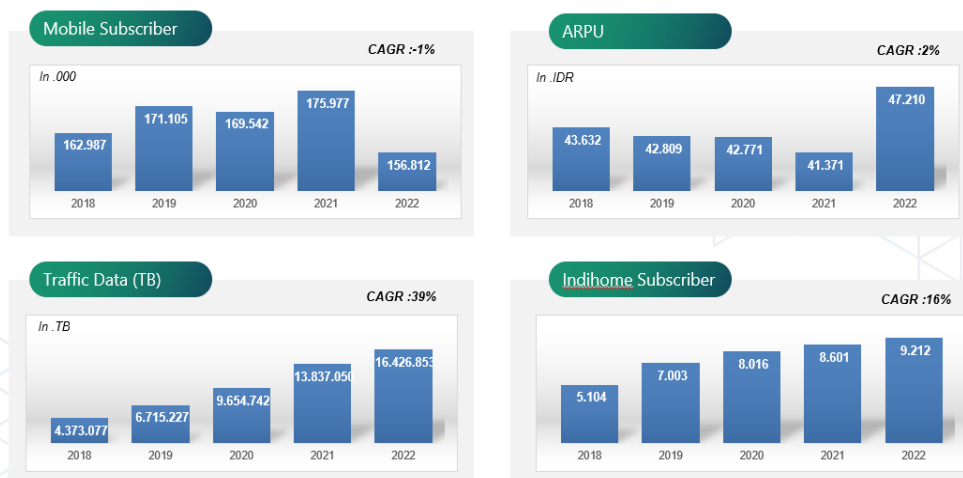

Source : Telkom annual report



Indicator	2018	2019	2020	2021	2022	CAGR
Traffic Data Selular (TB)	4.373.077	6.715.227	9.654.742	13.837.050	16.426.853	39%
Mobile Subscriber	162.987	171.105	169.542	175.977	156.812	-1%
Fixed Broadband (Indihome)	5.104	7.003	8.016	8.601	9.212	16%
BTS	189.081	212.235	231.172	251.116	265.194	9%
Tower	30.485	33.892	35.822	36.761	40.588	7%
FO Backbone (KM)	161.652	164.769	167.935	170.885	173.266	2%
ARPU Mobile	43.632	42.809	42.771	41.371	47.210	2%

Source : Telkom annual report

XL Axiata as the second largest mobile operator were experiencing a significant growth subscribers about 1.1mio during the initial period of pandemi (2019-2020) as shown on below table, and were relatively stays during 2020 till 2022. The data traffic shows a significant increase during and after pandemic with cagr 38%. On the other hand, the XL Home users are growing during pandemic and after pandemic >50 % similar strong trend with the home users in Telkom. The hikes in data traffic and home users during and continue after the pandemic were triggering the capital expenditure increase to serve the incremental capacity.

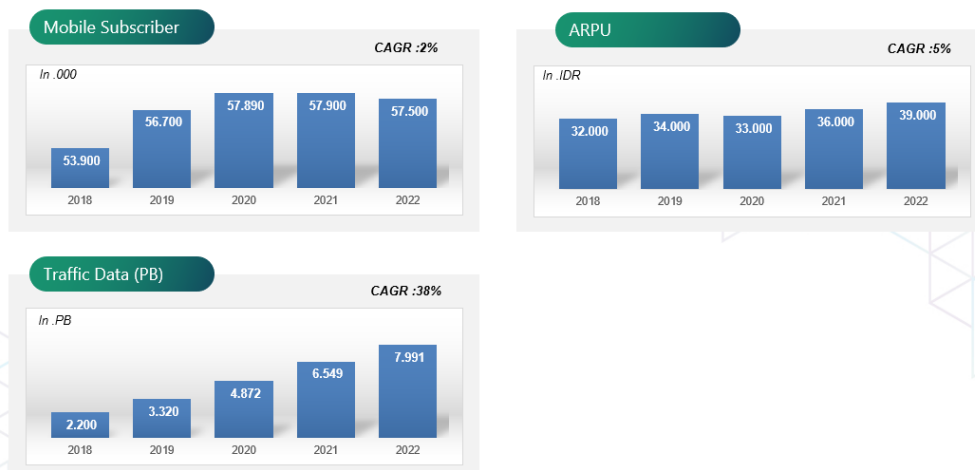

Source : XL Axiata annual report

Indicator	2018	2019	2020	2021	2022	CAGR
Traffic Data Selular (PB)	2.200	3.320	4.872	6.549	7.991	38%
Mobile Subscriber	53.900	56.700	57.890	57.900	57.500	2%
ARPU Mobile	32.000	34.000	33.000	36.000	39.000	5%

Source : XL Axiata annual report

The incremental capital were required by both companies, not only during pandemic but continued after the pandemic due to the incremental data traffic and users (especially home users) driving by the new way of working. It was compensated with the incremental revenue from mobile and home data subscribers that was strong during the pandemic and continue after pandemic. New way of discussion using Zoom, Teams, and Meet were raised during pandemic and become a preferred alternative for business discussion and education class even after pandemic. We study the financial ratios during and after pandemic Covid-19 of both companies with following results.

**Accounting Inquiries with New Approaches in the Post-Pandemic Era
Volume I**

1. The Return On Investment

Both companies have a positive growth in terms of profit, along with the equity and long term liability to cover the long term infrastructure or asset required to add fiber networks and capacity.

PT. Telkom	2019	2020	2021	2022
Laba Tahun Berjalan	27.592	29.563	33.948	27.680
Total Ekuitas	117.250	120.889	145.399	149.262
Lialibilitas Jangka Panjang	45.589	56.961	62.654	55.542
ROI	16.9%	16.6%	16.3%	13.5%

PT. XL Axiata	2019	2020	2021	2022
Laba Tahun Berjalan	726	372	1.288	1.121
Total Ekuitas	19.121	19.138	20.088	25.643
Lialibilitas Jangka Panjang	22.311	29.750	31.711	35.153
ROI	1.8%	0.8%	2.5%	1.8%

The trend is going down slightly for PT. Telkom during and after pandemic. And it was decline during pandemic and rebound for PT. XL Axiata after the pandemic.

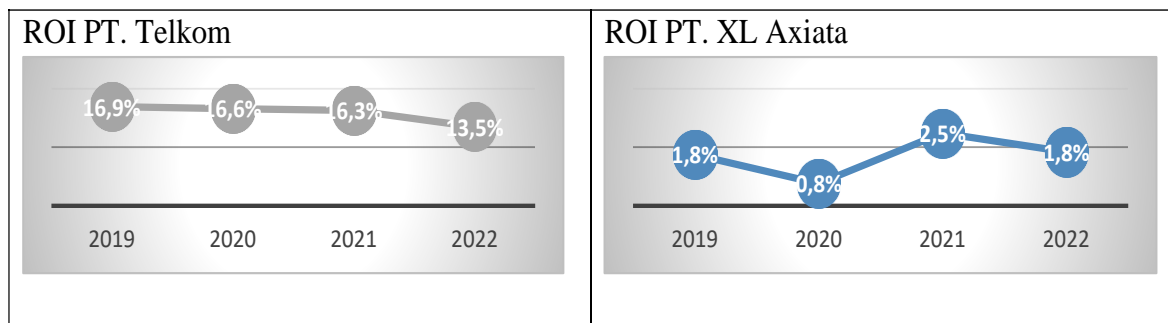

2. The Return On Equity

Both companies have a positive growth in terms of profit, along with the equity.

PT. Telkom	2019	2020	2021	2022
Laba Tahun Berjalan	27.592	29.563	33.948	27.680
Total Ekuitas	117.250	120.889	145.399	149.262
ROE	23.5%	24.5%	23.3%	18.5%

PT. XL Axiata	2019	2020	2021	2022
Laba Tahun Berjalan	726	372	1.288	1.121
Total Ekuitas	19.121	19.138	20.088	25.643
ROE	3.8%	1.9%	6.4%	4.4%

And the ROE shows similar trend with the ROI which going down slightly for PT. Telkom during and after pandemic. And fluctuation a bit, with decline during pandemic and rebound for PT. XL Axiata after the pandemic.

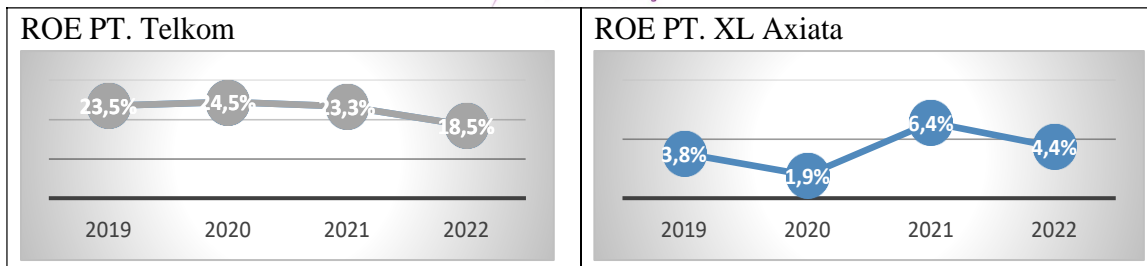

3. The Cash Ratio

Both companies show a strong cash and equivalent with cash, having a growth during and after pandemic. On the Liabilities, XL Axiata having a slight decline in 2020 but rebound again in 2021 and 2022

PT. Telkom	2019	2020	2021	2022
Kas dan Setara Kas	18.242	20.589	38.361	31.947
Lialibilitas Jangka Pendek	58.369	69.093	69.131	70.388
Cash Ratio	31%	30%	55%	45%

PT. XL Axiata	2019	2020	2021	2022
Kas dan Setara Kas	1.603	2.966	2.664	5.184
Lialibilitas Jangka Pendek	21.292	18.857	20.954	26.350
Cash Ratio	8%	16%	13%	20%

The trend of the cash ratio was increasing during and after pandemic, both for PT. Telkom and PT. XI Axiata.

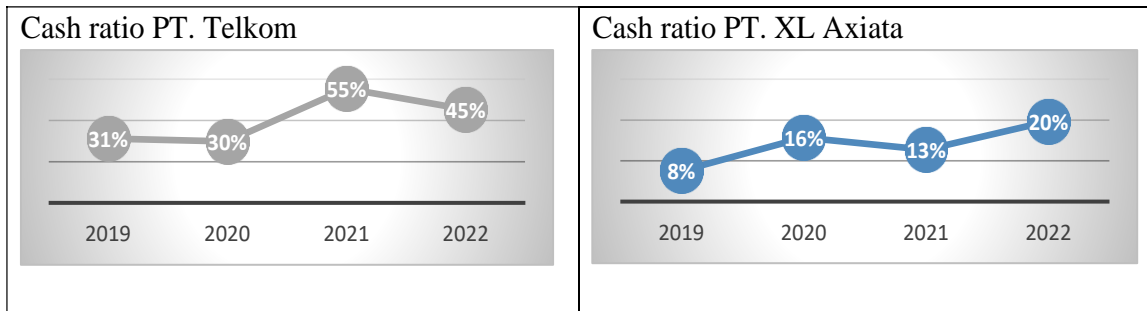

4. The Current Ratio

Both companies show a normal fluctuation during and after pandemic. Giving an indication that cash and current asset were not going drain during the pandemic.

PT. Telkom	2019	2020	2021	2022
Total Current Asset	41.722	46.503	61.277	55.057
Total Lialibilitas Jangka Pendek	58.369	69.093	69.131	70.388
Current Ratio	71%	67%	89%	78%

**Accounting Inquiries with New Approaches in the Post-Pandemic Era
Volume I**

	2019	2020	2021	2022
PT. XL Axiata				
Total Current Asset	7.146	7.571	7.733	10.408
Total Lialibilitas Jangka Pendek	21.292	18.857	20.954	26.350
Current Ratio	34%	40%	37%	39%

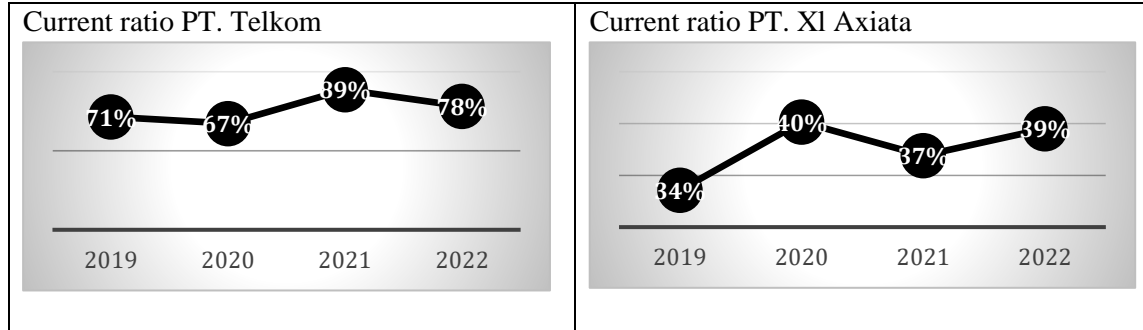

5. The Total Asset Turn Over

PT. Telkom	2019	2020	2021	2022
Total Asset	221.208	246.943	277.184	275.192
Pendapatan	135.567	136.462	143.210	147.306
Total Asset Turn Over	61%	55%	52%	54%
PT. XL Axiata	2019	2020	2021	2022
Total Asset	62.726	67.745	72.753	87.277
Pendapatan	25.150	26.018	26.766	29.172
Total Asset Turn Over	40%	38%	37%	33%

Total asset turn over on both companies during and after pandemic shows a decline trend according to the incremental number of asset higher than incremental revenue

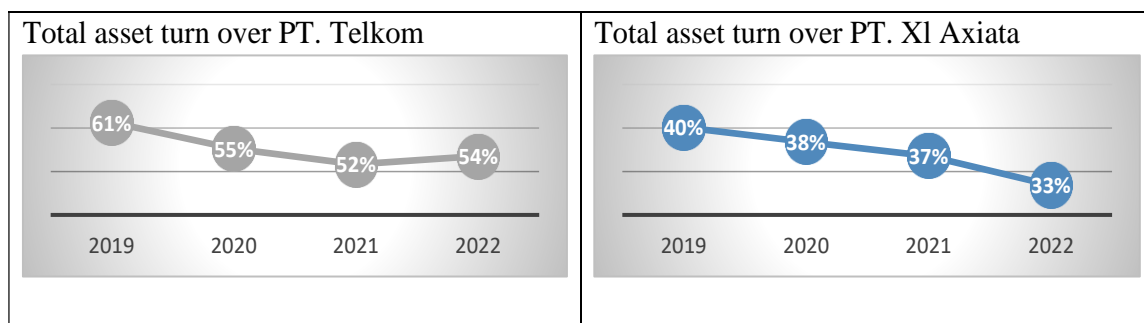

6. The Equity to Asset ratio

PT. Telkom	2019	2020	2021	2022
Total Ekuitas	117.250	120.889	145.399	149.262
Total Asset	221.208	246.943	277.184	275.192
Equity to Total Aset Ratio	53%	49%	52%	54%
PT. XL Axiata	2019	2020	2021	2022
Total Ekuitas	19.121	19.138	20.088	25.643
Total Asset	62.726	67.745	72.753	87.277
Equity to Total Aset Ratio	30%	28%	28%	29%

The Equity to asset ratio on both companies experiencing a decline trend during pandemic and rebound after pandemic.

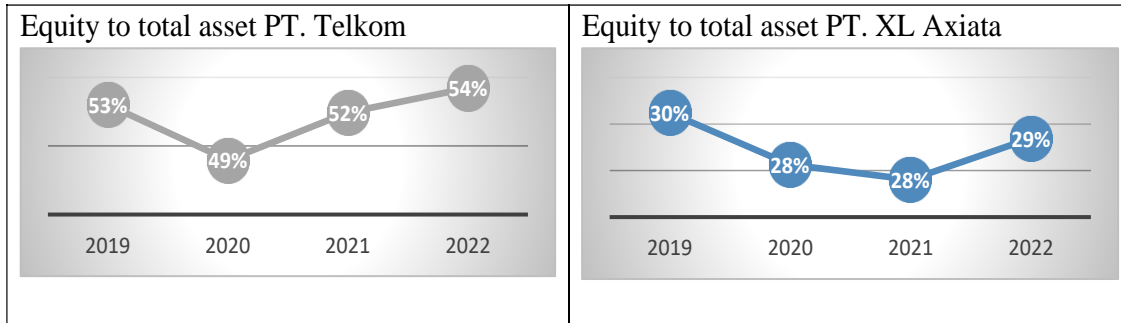

We correlate the ratio results with the standard from the SOE Ministry Decree No. KEP 100/MBU/2002 which determine the score for each ratio based on the intervals shows on the Methodology. The total score for both companies shows as follows :

a. PT. Telkom, year 2019

No	Rasio	Result	Score based on SOE KEP 100/ MBU/2002	Weighted Score
1	Return on Investment	16,9%	13,5	49 x (100/60) = 81,7
2	Return on Equity	23,5%	20	
3	Cash Ratio	31%	4	
4	Current Ratio	71%	0	
5	Total Asset Turn Over	61%	3	
6	Equity to Asset ratio	53%	8,5	

b. PT. Telkom, year 2020

No	Rasio	Result	Score based on SOE KEP 100/ MBU/2002	Weighted Score
1	Return on Investment	16,6%	13,5	49 x (100/60) = 81,7
2	Return on Equity	24,5%	20	
3	Cash Ratio	30%	4	
4	Current Ratio	67%	0	
5	Total Asset Turn Over	55%	2,5	
6	Equity to Asset ratio	49%	9	

c. PT. Telkom, year 2021

No	Rasio	Result	Score based on SOE KEP 100/ MBU/2002	Weighted Score
1	Return on Investment	16,3%	13,5	49,5 x (100/60) = 82,5
2	Return on Equity	23,3%	20	
3	Cash Ratio	55%	5	
4	Current Ratio	89%	0	

**Accounting Inquiries with New Approaches in the Post-Pandemic Era
Volume I**

5	Total Asset Turn Over	52%	2,5	
6	Equity to Asset ratio	52%	8,5	

d. PT. Telkom, year 2022

No	Rasio	Result	Score based on SOE KEP/ 100/ MBU/2002	Weighted Score
1	Return on Investment	13,5%	12	49 x (100/60) = 81,7
2	Return on Equity	18,5%	20	
3	Cash Ratio	45%	5	
4	Current Ratio	78%	0	
5	Total Asset Turn Over	54%	2,5	
6	Equity to Asset ratio	54%	8,5	

e. PT. XL Axiata, year 2019

No	Rasio	Result	Score based on SOE KEP/ 100/ MBU/2002	Weighted Score
1	Return on Investment	1,8%	3	22 x (100/60) = 37
2	Return on Equity	3,8%	5,5	
3	Cash Ratio	8%	1	
4	Current Ratio	34%	0	
5	Total Asset Turn Over	40%	2,5	
6	Equity to Asset ratio	30%	10	

f. PT. XL Axiata, year 2020

No	Rasio	Result	Score based on SOE KEP/ 100/ MBU/2002	Weighted Score
1	Return on Investment	0,8%	2	18,25 x (100/60) = 31
2	Return on Equity	1,9%	4	
3	Cash Ratio	16%	3	
4	Current Ratio	40%	0	
5	Total Asset Turn Over	38%	2	
6	Equity to Asset ratio	28%	7,25	

g. PT. XL Axiata, year 2021

No	Rasio	Result	Score based on SOE KEP/ 100/ MBU/2002	Weighted Score
1	Return on Investment	2,5%	3	22,8 x (100/60) = 38
2	Return on Equity	6,4%	8,5	
3	Cash Ratio	13%	2	
4	Current Ratio	37%	0	
5	Total Asset Turn Over	37%	2	
6	Equity to Asset ratio	28%	7,25	

h. PT. XL Axiata, year 2022

No	Rasio	Result	Score based on SOE	Weighted Score
----	-------	--------	--------------------	----------------



			KEP/ 100/ MBU/2002	
1	Return on Investment	1,8%	3	22,25 x (100/60) = 37,08
2	Return on Equity	4,4%	7	
3	Cash Ratio	20%	3	
4	Current Ratio	39%	0	
5	Total Asset Turn Over	33%	2	
6	Equity to Asset ratio	29%	7,25	

All the calculation leading to the financial health level based on ministry decree SOE KEP/100/ MBU/2002 for both companies as follows :

Year	Companies	Total weighted score	Financial Health level
2019	PT. Telkom	81,7	AA
2020		81,7	AA
2021		82,5	AA
2022		81,7	AA
2019	PT. XL Axiata	37	B
2020		31	B
2021		38	B
2022		37,08	B

CONCLUSION, RECOMMENDATION, LIMITATION

The study shows that despite the huge shift of behaviour from the people, huge change of doing business, schools, and many other activities during the pandemic and after pandemic, the telecommunication industry still having a good and sustainable financial health showed by the following parameter :

- a. Total weighted score based on SOE KEP/100/ MBU/2002 are relatively similar during and after pandemic. There were no big drop on the ratios we calculate on this research.
- b. The total revenue for both companies in telecommunication industry were increase despite the pandemic while both companies could smartly maintain the cost and assets
- c. The net income also shows a steady and stable result. While also successfully managing the incremental investment and equity.
- d. Both companies also have adequacy cash to maintain their liquidity during and after pandemic

We recommend the Telecommunication Industry to continue their plan and activities which may give them higher results after pandemic. This driven by the additional traffic on the

acceleration of the digital transformation and incremental transactions for the people after the pandemic.

Limitation on the result and recommendation are only use the 4 year data from 2019 when the pandemic just started in China till 2021 which most of government in the world had declared that pandemic has ended. The other limitation on this study is on the no assessment on the additional factor (operation and administration) to measure the healthy level of the company or industry.

ACKNOWLEDGEMENT

The study is involving some staff members working in XI Axiata Enterprise ie. Antonius Hasan as the senior staff on the business performance (before 1 May 2023) and partnership product (after 1 May 2023) as well as Aun Abdul Wadud as the digital transformation enthusiast. Very high gratitude to both of them which giving their views and data.

REFERENCES

- PT, Telkom Indonesia. (2019). Annual Report.
- PT, Telkom Indonesia. (2020). Annual Report.
- PT, Telkom Indonesia. (2021). Annual Report.
- PT, Telkom Indonesia. (2022). Annual Report.
- PT, XL Axiata. (2019). Annual Report.
- PT, XL Axiata. (2020). Annual Report.
- PT, XL Axiata. (2021). Annual Report.
- PT, XL Axiata. (2022). Annual Report.
- "The Industry Handbook: The Telecommunications Industry". 7 January 2004.*
- "2017 Telecommunications Industry Outlook - Deloitte US". Deloitte United States.*
- <https://www.mckinsey.com/capabilities/strategy-and-corporate-finance/our-insights/how-covid-19-has-pushed-companies-over-the-technology-tipping-point-and-transformed-business-forever#/>
- [https://www.europarl.europa.eu/RegData/etudes/STUD/2022/733986/IPOL_STU\(2022\)733986_EN.pdf](https://www.europarl.europa.eu/RegData/etudes/STUD/2022/733986/IPOL_STU(2022)733986_EN.pdf)
- <https://www.accenture.com/us-en/insights/digital-transformation-index>
- <https://jdih.bumn.go.id/peraturan/KEP-100-MBU-2002>



CHAPTER 8

The Effect of Workload And Work Environment on Employee Performance with Work Stress as a Mediating Variable. As Seen in the Evidence of PT Matra Perkasa Utama

Ir. Amelia Naim INDRAJAYA

Sekolah Tinggi Manajemen IPMI
amelia.naim@ipmi.ac.id
Orcid: 0000-0001-9021-902X

Medyna ROESLY SE. Ak.

Sekolah Tinggi Manajemen IPMI
medyna.roesly@ipmi.ac.id
Orcid: 0000-0001-7166-1998

ABSTRACT

Employee performance is a delicate matter influenced by workload, work environment, and work stress. One of the business phenomena as seen in the current news is the declining employee performance. One of the phenomena as seen from a case study the employee performance is declining from 80% in 2015 to 70% in 2021, which is below the minimum required rate of 85%. However, there is still limited research looking at employee performance as seen from the workload and work environment with the moderating impact of work stress. This paper is filling up the gap by analyzing the impact of workload and work environment toward employee performance, mediated by work stress. The validity and reliability of the measurement system is showing strong support with accepted Cronbach alpha. The limitation of this paper lies in the limited amount of empirical data. Further research should also be conducted empirically with more sets of data.

Keywords: Work Stress, Workload, Work Environment, Employee Performance



INTRODUCTION

Indonesia, based on data from Civil Registry Service Office, in the first semester of 2022, has more than 275 million people with an average population density of 145 per kilometer square. It is also well known for its vast land area; 62,97% are forest areas, which amounted to 125,76 million hectares. According to BPS, over the previous five years (2017-2021), Indonesia's forest has shrunk by 956.258 hectares or 0.5% of its land area. Forest fires and the clearing of new crops cause this deforestation. Each year, land and forest fires in Indonesia fluctuate, with the deadliest in 2019 burning off 1,6 million hectares of land. Indonesia is the world's largest peat region, with over 15 million hectares distributed over Sumatra, Kalimantan, and Papua. This peat region is prone to forest fires. The annual forest fire calamity in Indonesia continues. This tragedy will result in environmental and economic harm. As a result, the government must have comprehensive legislation to prevent and control forest and land fires in Indonesia and also to protect its citizen, particularly in areas prone to such calamities.

These conditions created a significant market potential for firefighting vehicle manufacturers such as PT Matra Perkasa Utama. According to SIRUP LKPP (Sistem Informasi Rencana Umum Pengadaan), the overall budget for firefighting vehicles and equipment in Indonesia is Rp 319 billion till June 2022. Unfortunately, the firefighting vehicle market is fragmented, with only a few manufacturers in Indonesia.

In carrying out its operational operations, PT. Matra Perkasa Utama constantly enhances its workers' performance quality to make the items trustworthy. This decrease demonstrates staff performance at PT. Matra Perkasa Utama Bekasi is ineffective and inefficient—employee performance at PT. Matra Perkasa Utama Bekasi is influenced by the workload employees feel; employees believe the burden assigned is not following their competence and comprehension; thus, they believe the task assigned is relatively severe. PT. Matra Perkasa Utama Bekasi also does not give employees pleasant working settings and conditions, leading employees to feel stress due to a fairly heavy workload and an unfavorable work environment. These situations, of course, impact staff performance at PT. Matra Perkasa Utama Bekasi, which is declining 80 in 2015 and 70 in 2021 below 85% standard.

Globalization forced every organization to continue to grow to compete in an increasingly challenging and competitive market. All organizations must increase the quality of their human resources to benefit the company and win the intense rivalry among businesses. Businesses must be able to control the workforce's function to contribute to achieving corporate goals effectively and efficiently

1. RESEARCH GAP

There are a lot of previous researchers that researched in terms of employee performance, where workload and work environment positively impact employee performance. However, there are minimal studies about influencing variables of work stress as a mediating role in the correlation between workload, work environment, and employee performance specific for fire fighting vehicle manufacturers; as mentioned

earlier, the business is tailor-made (customized) based on customer requirements. This customer-centric model would have unique references that cannot be compared with previous regards in general.

Sari et al. (2019) published a study named *The Influence of Workload and Work Environment on Employee Performance with Work Stress as an Intervening Variable at PT Batanghari Barisan Padang*. The workload had a negative and negligible influence on job stress, but the work environment had a positive and substantial effect. Additionally, workload and work environment have a beneficial but minor influence on employee performance. Workload and work environment have a good and significant impact on job stress. According to these findings, workload and work environment favorably and substantially influence employee performance. This study also reveals that job stress cannot mitigate the impact of workload and work environment on each employee's performance.

Sofiana et al. (2020), with the research title "*The Effect of Workload and Work Stress on the Performance of Teaching Staff at the Pontianak State Polytechnic*." Work stress did not influence teaching staff performance, although workload affected teaching staff work stress.

2. RESEARCH QUESTION

According to the identified problem, this research will answer the following 7 (seven) research questions as follow : 1) Does workload affect work stress?, 2) Does the work environment affect work stress?, 3) Does workload affect employee performance?, 4) Does the work environment affect employee performance?, 5) Does work stress affects employee performance?, 6) Does work stress mediate the effect of workload on employee performance?, 7) Does work stress mediate the effect of the work environment on employee performance?

3. LITERATURE REVIEW

3.1. Workload

The workload is a responsibility assigned by superiors that must be accomplished within the specified time frame to achieve goals (Husin, Nurwati, & Aisyah, 2021). The workload is a collection of activities that demand mental processes or talents to be done in a specific amount of time, both physically and psychologically (Hamizar, 2020). The workload is the perceived link between the number of mental processing abilities or resources required by the task (Hart and Staveland in Siburian et al., 2021). Some factors affect workload: task demand, effort or energy, and performance (Tarwaka, 2015). Koesomowidjojo (2017) emphasizes the indicators to determine the workload, including work conditions, use of working time, and targets that must be achieved.

3.2. Work Environment

The work environment is one of the aspects that the company must use to increase the organization's performance by providing comfort and calm. The work environment is everything around the employee, whether physical or non-physical, direct or indirect,



which can affect himself and his career while working (Ronald & Hotlin, 2019). Sedarmayanti (2016) states that the work environment is the entire tooling and material encountered, the surrounding environment where a person works, his work methods, and work arrangements as individuals and groups. The indicators in the work environment are as follows (Nitisemito, 2015) working atmosphere, relationship with colleagues, relationship with superiors, work or rest hours, availability of work facilities, and work safety

3.3 Employee Performance

Employee performance is a result of qualitative and quantitative performance that can be achieved by a person or group of people in an organization following their authority, duties, and responsibilities to achieve the goals of the organization concerned legally, without violating the law, and following morals or ethics (Moehariono in Tutu et al., 2022). Employee performance is influenced by competency, knowledge, work design, personality, work motivation leadership, leadership style, organizational culture, job satisfaction, work environment, loyalty, commitment, and work discipline (Kasmir, 2016). Performance indicators will be calculated and measured by using quality of work, working quantity, task implementation, and responsibility towards work as indicators (Mangkunegara, 2015).

3.4. Work Stress

Work stress is a negative emotional situation characterized by tension that influences the formation of physiological, psychological, and behavioral reactions (stress reduction) by humans to adapt to stressful, frightening, and harmful occurrences (Steven et al., 2019). Symptoms of job stress include emotional instability, feeling uneasy, being alone, difficulty sleeping, excessive smoking, inability to relax, anxiety, tension, nervousness, raised blood pressure, and digestive problems (Pantouw et al., 2020). In this study, work stress is conceptualized as an emotional state resulting from demands from inside and outside the company, with workload, working time, feedback, and responsibility as indicators (Mangkunegara, 2017).

3.5. Effect of Workload on Work Stress

The workload is connected to work stress, as are the reasons for work stress, such as having an excessive workload, a disproportionate quality of supervision, feeling stressed or under time pressure, role ambiguity, inadequate authority, different types of change, and interpersonal conflicts that are perceived (Suryaningrum in Raharja & Heryanda, 2021). A heavy workload can lead to stress if individuals are asked to work on a subject they do not understand or differ from their expertise and ability (Zulmaidarleni et al., 2019). A high loading level allows excessive energy expenditure and overstress, whereas a low loading intensity allows boredom and under-stress (Andriani in Ananda et al., 2021).

H1: Workload positively affects Work Stress

3.6. Effect of Work Environment on Work Stress

The social, psychological, and physical life at a firm that impacts personnel in carrying out their tasks is referred to as the work environment. The organization should be able to reflect settings that encourage collaboration among superiors, subordinates, and those in the same job status inside the company. A secure and comfortable work environment creates a sense of security and comfort, allowing people to perform efficiently and effectively without feeling overwhelmed. Excessive stress impairs a person's capacity to interact with the environment, resulting in various stress symptoms that interfere with employment. Employees will carry out job tasks if they like the work environment in which they work, allowing them to make better use of their working time (Puspitasari et al., 2021).

H2: Work Environment positively affects Work Stress

3.7. Effect of Work Stress on Employee Performance

Work stress can either improve or hurt work performance, depending on the level of stress (Davis & Newstrom, 2008). When there is no stress, there is no work challenge, and work performance suffers. Work performance tends to improve as stress levels rise, because stress helps individuals direct all resources toward achieving work demands. If a healthy stimulus motivates employees to respond to employment challenges, stress levels will eventually stabilize at a level that closely corresponds to the employee's performance skills. Additional stress is less likely to result in increased job performance at this time. According to Davis and Newstrom (2008), if stress becomes too much, work performance will begin to diminish because stress interferes with work execution. Employees lose control of themselves, become unable to make decisions, and exhibit erratic conduct. The most severe repercussions include zero work performance, employees experiencing disruptions, being ill and unable to work, despair, leaving or refusing to work to escape stress. In his research, Iskanto (2021) concludes that work stress has a considerable impact on employee performance.

H3: Work stress negatively affects employee performance

3.8. Effect of Workload on Employee Performance

The workload assigned to employees is a significant factor that management must consider because it can determine an employee's efficacy and productivity in completing their work and performance. Employee workload significantly affects employee performance based on how much burden is received by employees; therefore, employee performance in completing work is not optimal (Phalis, 2020). Businesses must recognize their employees' abilities and change their tasks accordingly. Employees' incapacity to accomplish their work is caused by an imbalance between their ability and the workload that is forced on them, so providing larger workloads might diminish employee performance (Sasanti & Irbayuni, 2022)

H4: Workload positively affects Employee Performance

3.9. Effect of Workload on Employee Performance



The organization must consider the work environment as one of the aspects that can affect employee performance. This is because the conditions of a decent working environment will supply employees with work motivation to complete their assignments. A friendly and pleasant work environment indicates that the organization has demonstrated to its employees that they are valued and that their work is more enjoyable (Asnawi, 2020). An employee who works in a work environment that allows him to work optimally will produce good results; on the other hand, if an employee works in an inadequate work environment that does not allow him to function optimally, he will become lazy and tired quickly, resulting in poor performance (Bambang in Nurhandayani, 2022).

H5: Work environment positively affects employee performance

3.10. Potential Mediating Role of Work Stress

Employees may experience pressure and work stress as a result of their workload. Nonetheless, individuals may still concentrate at work and reduce workplace blunders. As a result, the mental stress that happens falls into the low group. Too much labor can produce tension and stress in a person. This is due to the high degree of skill necessary, the excessive pace of work, the excessive amount of work, and so on (Muhareni et al., 2022). If prolonged, high and low levels of job stress might affect employee performance due to pressure in carrying out tasks (Wirya & Andiani, 2020). A pleasant working environment motivates people to work harder and focus on finishing their assignments on time. A stressful work environment causes employees to be unable to do their tasks correctly, which can lead to lower employee performance (Sari et al., 2019). This pleasant and conducive work environment will affect employees' ability to carry out their jobs while lowering employee stress levels; conversely, if it is not conducive and excellent, it will impact high employee work stress (Pantouw et al., 2020).

H6: Workload positively affects employee performance with work stress as a mediating variable

H7: Work environment positively affects employee performance with work stress as a mediating variable

3.11. Conceptual Framework Development

The conceptual framework in this study is meant as the fundamental basis that will be employed in the construction of hypotheses. As stated in the research objectives, the study will investigate the impact of workload and work environment on employee performance as mediated by work stress. The relationship between the concepts is shown in Figure 1

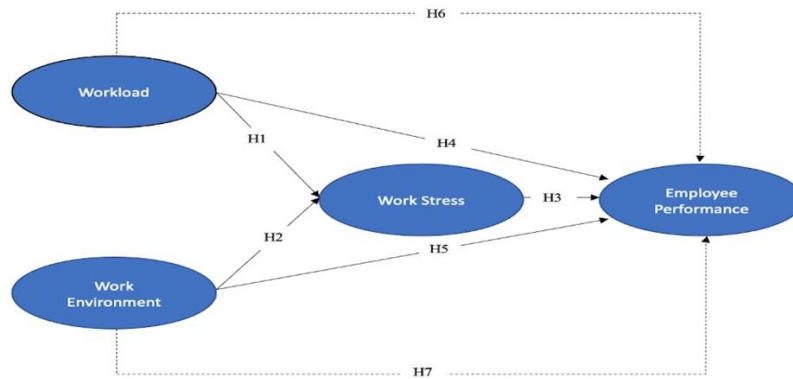

Figure 1. Conceptual Framework

Based on the research framework, there are several hypotheses to examine:

H1: Workload positively affects Work Stress.

H2: Work Environment positively affects Work Stress

H3: Work stress negatively affects Employee Performance.

H4: Work load positively affects employee performance.

H5: Work environment positively affects employee performance

H6: Workload positively affects employee performance with work stress as a mediating variable

H7: Work environment positively affects employee performance with work stress as a mediating variable

METHODS

This study employs quantitative methodologies. This study's population consisted of 44 (forty-four) employees. The census method was employed to collect data since the complete population was sampled. Prior data analysis were conducted, validity and reliability test, using Cronbach's Alpha and Pearson's Correlation are run. To analyse data and test hypotheses, the PLS-SEM 4 software is employed. The following are the assessment criteria for the Partial Least Square model proposed by Chin (1998) in Ghozali (2006).

Table 1 PLS Assessment Criteria for Structural Model

Criteria	Explanation
Structural Model Evaluation	
R ² for endogenous latent variables	R ² results of 0.67, 0.33 and 0.19 for endogenous latent variables in the structural model indicate that the model is "good" "moderate", and "weak"
Estimated path coefficients	The estimated values for the path relationships in the structural model must be significant. This significant value can be obtained by bootstrapping procedures.
f ² for effect size	The f ² values of 0.02, 0.15, and 0.35 can be interpreted whether the predictors of latent variables have a weak, medium or large influence at the structural level.

RESULT AND CONCLUSION

Pilot testing are run on a small scale to ensure the instruments are good, and the respondents understand the items. First, to check the internal consistency (reliability) Cronbach's alpha reliability coefficients were used (Zikmund et al., 2013). As a result, the questionnaires were reliable, resulting in Cronbach's alpha values of 0.70 as a minimum point of reliability (Sekaran & Bougie, 2010). Second, to distinguish the validity of the questionnaires, Pearson's Correlation is being utilized. Pearson (1948) said 0.3 is the legitimacy of the relationship between the factors to quality their good run. Research model that used in this research are shown below on Figure 2.

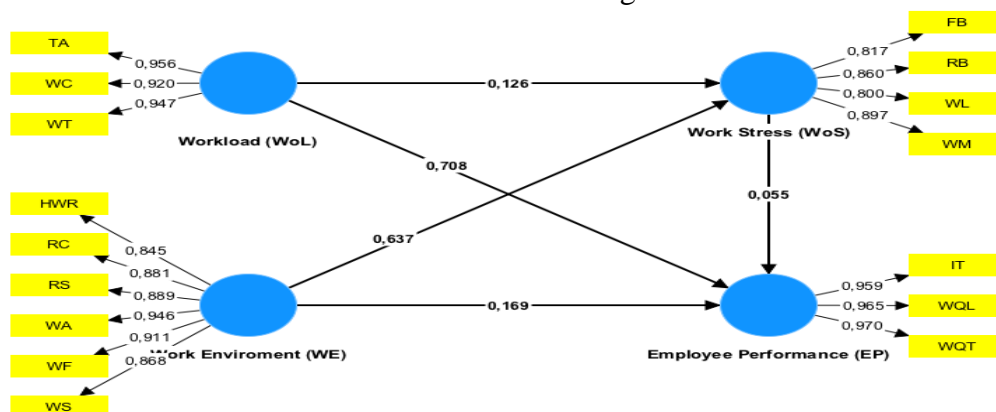

Figure 2. Research model

As can be seen in Table 2 below, the R^2 of Employee Performance, has the highest precision's level (0.812) it is substantial level and close to 1 as an indication of great prediction accuracy, that Employee Performance as an independent variable explaining that 81.2% of dependent variables, which are Workload, Work Environment and Work Stress. the R^2 of Work Stress, has the precision's level (0.551) it is moderate level, that Work Stress as an independent variable influenced by 55,1% of dependent variables, which are Workload, Work Environment. The remaining percentage is influenced by variables that were not included in this research.

Table 2 Coefficient of Determination (R^2)

Variable	R Square
Employee Performance	0.812
Work Stress	0.551

As shown in Table 3, the second criteria on structural model evaluation in the current study, the WoL to EP, WE to EP, WoS to EP, WoL to WoS and WE to WoS, all show positive correlations with path coefficients. Nevertheless, WoS to EP appears to be the weakest among the other relationships. Because all the VIF values are less than 10, there are no collinearity issues. The table also shown study that the model has small f^2 on

the effect of Workload (WoL) on Work Stress (WoS) (0.005), and shown on Work Environment on the Employee Performance (EP) (0.020) and also on Work Stress (WoS) on Employee Performance (EP) (0.007). A medium f^2 on the effect of Work Environment (WE) to Work Stress (WoS) (0.128). Large f^2 (0.384) shown for Workload (WoL) on Employee Performance (EP).

Table 3 Path coefficient, VIF and f^2

Effect	Path Coefficient	VIF	f^2
Workload → Employee Performance	0.708	7.444	0.384
Work Environment → Employee Performance	0.169	8.355	0.020
Work Stress → Employee Performance	0.055	2.336	0.007
Workload → Work Stress	0.126	7.407	0.005
Work Environment → Work Stress	0.637	7.407	0.128

Based on the table below, not all hypothesis are supported. The relationship between Work Environment (WE) and Work Stress (WoS) is significant (H2) with a path coefficient of 0.637, a t-value of 1.808, and a p-value of 0.071. This implies that WE has a medium effects on the Work Stress (WoS). The relationship between Workload (WoL) and Employee Performance (EP) is significant (H4) with a path coefficient of 0.708, a t-value of 3.217, and a p-value of 0.001. This implies that Workload (WoL) has a large effects on the Employee Performance (EP).

Table 4 Hypothesis Testing Result

H	Effect	Path Coefficient	T statistic	P values	Confidence Interval		Result
					2.5%	97.5%	
H1	Workload → Work Stress	0.126	0.361	0.718	-0.662	0.698	H1 not supported
H2	Work Environment → Work Stress	0.637	1.808	0.071	0.058	1.434	H2 supported
H3	Work Stress → Employee Performance	0.055	0.589	0.556	-0.131	0.237	H3 not supported
H4	Workload → Employee Performance	0.708	3.217	0.001	0.248	1.149	H4 supported
H5	Work Environment → Employee Performance	0.169	0.622	0.534	-0.382	0.729	H5 not supported
H6	Workload → Work Stress → Employee Performance	0.007	0.173	0.863	-0.087	0.085	H6 not supported
H7	Work Environment → Work Stress → Employee Performance	0.035	0.458	0.647	0.095	0.216	H7 not supported



The primary goal of this research as follow to evaluate the effect of workload and work environment to employee performance with work stress as a mediating variable. In the relationship or workload, work stress and employee performance, t-values (0.173) and p-value (0.863) suggested that there is no correlation between variables, and has statistically not significant. This result is also shown in the relationship or work environment, work stress and employee performance, t-values (0.458) and p-value (0.647). In concluding this thesis, the author has addressed some of the gaps that were posed in the research questions. The findings suggest that Work Environment has a medium effect to Work Stress while Workload has a large effect on Employee Performance.

While the study offers valuable insights, it's essential to recognize its limitations. In order to overcome the limitations of this study, further research is necessary. It is imperative to broaden the research scope by incorporating a wider range of companies and comparing the manufacturing industry with other sectors, a larger sample size may result in a more representative sample to achieve a more generalizable outcome.

REFERENCES

- Ananda, M. S., Wadud, M., & Handayani, S. (2021). Pengaruh Beban Kerja Dan Lingkungan Kerja Terhadap Stres Kerja Pada Karyawan Pt. Kereta Api Indonesia (Persero) Divisi Regional Iv Tanjungkarang. *Jurnal Bisnis, Manajemen, Dan Ekonomi*, 2(4), 186–195. <https://doi.org/10.47747/jbme.v2i4.504>
- Davis, Keith & John W. Newstrom. 2008. *Perilaku Dalam Organisasi*. Edisi VII. Jilid II. Jakarta: Erlangga
- Hair Jr, J. F., Hult, G. T. M., Ringle, C. M., Sarstedt, M., Danks, N. P., & Ray, S. (2021). *Partial least squares structural equation modeling (PLS-SEM) using R: A workbook* (p. 197). Springer Nature.
- Hamizar, A. (2020). Pengaruh Beban Kerja Terhadap Kinerja Pegawai (Studi Kasus Pada Bps Maluku). *Jurnal Of Islamic Economic And Business*, 2(1), 52–63.
- Husin, Nurwati, & Aisyah, S. (2021). Pengaruh Beban Kerja Dan Kompensasi Terhadap Kinerja Pegawai Pada Badan Pengelolaan Keuangan Dan Aset Daerah Kabupaten Konawe Selatan. *Equilibrium*, 10(1), 69–78.
- Iskanto, D. (2021). Stress and its impact on employee performance. *International Journal of Social and Management Studies*, 2(3), 142-148.
- Kasmir. (2016). *Manajemen Sumber Daya Manusia (Teori Dan Praktik)*. Pt Rajagrafindo Persada.
- Asnawi, K. (2020). *Pengaruh Lingkungan Kerja Terhadap Kinerja Pegawai Dengan Motivasi Sebagai Variabel Intervening Pada Pt. Pratama Abadi Industri Sukabumi (Studi Pada Divisi Quality Control)*. 104–116.
- Koesomowidjojo, S. (2017). *Panduan Praktis Menyusun. Analisa Beban Kerja*. Raih Asa Sukses (Penebar Swadaya Grup).
- Mangkunegara, A. P. (2015). *Manajemen Sumber Daya Manusia*. Remaja Rosda Karya Bandung.
- Mangkunegara, A. P. (2017). *Manajemen Sumber Daya Manusia*. Bandung Remaja Rosdakarya.
- Muhareni, I., Rusdi, M., & Shalihah, B. M. (2022). Pengaruh Work Family Conflict Dan Beban Kerja Terhadap Kinerja Karyawan Wanita Dengan Stres Kerja Sebagai Variabel Intervening. *Al Huwiyah: Journal Of Woman And Children Studies*, 2(1). <https://doi.org/10.24042/jwcs.v2i1.11229>
- Nitisemito, A. S. (2015). *Manajemen Sumber Daya Manusia*. Bandung: Pustaka Setia.
- Nurhandayani, A. (2022). Pengaruh Lingkungan Kerja, Kepuasan Kerja, Dan Beban Kerja Terhadap Kinerja. *Jurnal Ekonomi Dan Bisnis Digital (Ekobil)*, 1(2), 108–110. <https://doi.org/10.58765/ekobil.v1i2.65>
- Pantouw, M., Areros, W., & Rumawas, W. (2020). Lingkungan Kerja Dan Stres Kerja Terhadap Kinerja Karyawan Pt. Sinar Galesong Prima. *Manager : Jurnal Ilmu Manajemen*, 5(4), 453.
- Phalis, A. P. A. (2020). Pengaruh Beban Kerja Terhadap Kinerja Pegawai Di Puskesmas Pantoloan Dengan Insentif Sebagai Variabel Moderating Effect Of Workload On Performance Of Employees In Pantoloan Puskesmas With Incentive As A Moderating Variable. *Jurnal Kolaboratif Sains Volume 03*,

Accounting Inquiries with New Approaches in the Post-Pandemic Era
Volume I

Nomor 02, Mei 2020, 03(02), 73–76.

- Puspitasari, D. A., Indriati, I. H., & Basri, A. I. (2021). Pengaruh Beban Kerja, Lingkungan Kerja Dan Kepemimpinan Terhadap Stres Kerja Karyawan. *Investasi: Jurnal Penelitian Ekonomi Dan Bisnis*, Raharja, K., & Heryanda, K. K. (2021). Pengaruh Beban Kerja Terhadap Stres Kerja Pegawai Bpbd Kabupaten Buleleng Dengan Lingkungan Kerja Sebagai Variabel Moderasi. *Bisma: Jurnal Manajemen*, 7(2), 201. <https://doi.org/10.23887/bjm.v7i2.31936>
- Ronal, S. D., & Hotlin, S. (2019). Pengaruh Lingkungan Kerja Terhadap Kinerja Karyawan Pada Pt Super Setia Sagita Medan. *Jurnal Ilmiah Socio Secretum*, 9(2), 273–281.
- Sari, V. N., Safitri, R., & Sulistyowati, E. (2019). *Pengaruh Beban Kerja, Religiusitas Dan Lingkungan Kerja Terhadap Kinerja Karyawan Dengan Stres Kerja Sebagai Variabel Intervening (Studi*. 12(1), 135.
- Sasanti, M. A., & Irbayuni, C. A. S. (2022). Pengaruh Beban Kerja Dan K3 Terhadap Kinerja Karyawan Pada Bagian Produksi. *Jurnal Ekonomi, Manajemen Dan Akuntansi*, 24(3), 556–561. <https://doi.org/10.29264/jfor.v24i3.11307>
- Sedarmayanti. (2016). *Manajemen Sumber Daya Manusia Reformasi Birokrasi Dan Manajemen Pegawai Negeri Sipil*. Pt. Refika Aditama.
- Siburian, M. S., Pio, R. J., & Sambul, S. A. P. (2021). Pengaruh Beban Kerja Dan Lingkungan Kerja Terhadap Kinerja Karyawan Kantor Pelayanan Pajak Pratama Balige Sumatera Utara. *Productivity*, 2(5), 370–377.
- Sofiana, E., Wahyuarini, T., & Noviena, S. (2020). Pengaruh Beban Kerja Dan Stress Kerja Terhadap Kinerja Staf Pengajar Politeknik Negeri Pontianak. *Inovbiz: Jurnal Inovasi Bisnis*, 8(1), 1. <https://doi.org/10.35314/inovbiz.v8i1.1128>
- Steven, W., Sahrah, A., & Pendahuluan, A. (2019). *Terhadap Stres Kerja Karyawan*. 5(2), 101–109.
- Tarwaka. (2015). *Ergonomi Industri Dasar-Dasar Pengetahuan Ergonomi Dan Aplikasi Di Tempat Kerja*. Harapan Press.
- Tutu, R. V. B., Aremos, W. A., & Rogahang, J. J. (2022). Pengaruh Budaya Organisasi Dan Lingkungan Kerja Terhadap Kinerja Karyawan Pt. Astra International Daihatsu Tbk Cabang Manado. *Jurnal Productivity, E-Issn. 2723-0112*, 3(1), 24–29.
- Wirya, K. S., & Andiani, N. D. (2020). Pengaruh Stres Kerja Dan Kepuasan Kerja Terhadap. *Available On Line At Hppt://Www. Google. Com*, 2(1), 50–60.
- Zulmaidarleni, Z., Sarianti, R., & Fitria, Y. (2019). Pengaruh Beban Kerja Dan Lingkungan Kerja Fisik Terhadap Stres Kerja Pada Pegawai Kantor Kecamatan Padang Timur. *Jurnal Ecogen*, 2(1), 61. <https://doi.org/10.24036/jmpe.v2i1.6133>



CHAPTER 9

The Impact of Television Media Advertising, Product Quality, and Price on Consumer Purchasing Decisions for Indosat Service Providers in Indonesia

Sugiyono

Postgraduate Doctorate Student
Universitas Bhayangkara Jakarta Raya, Indonesia
202230152010@mhs.ubharajayaa.ac.id
Orcid : 0009-0006-7379-3648

Lisna Nurpida

Postgraduate Doctorate Student
Universitas Bhayangkara Jakarta Raya, Indonesia
202230152009@mhs.ubharajaya.ac.id
Orcid : 0009-0006-6777-3464

Dewi Puspaningtyas Faeni

Lecturer of Postgraduate Doctorate
University of Bhayangkara Jakarta Raya, Indonesia
dewi.puspaningtyas@dsn.ubharajaya.ac.id
Orcid : 0000-0002-1911-4425

ABSTRACT

The purpose of this study is to analyze how advertising channels, product quality, and pricing all influence Indosat subscribers' decisions to subscribe to the service. Using a simple random sampling procedure, a group of anywhere from 10 to 100 people are selected at random to fill out a questionnaire. Correlation, regression, and hypothesis tests were the analytical tools used both partially and simultaneously. The study's findings corroborate this. Therefore, this research was carried out to ascertain the effect of marketing on Training Provider product purchases. using data from one hundred people in a range of settings. The items sold by Indosat service providers are very diverse based on this research survey and research findings. The quality of the products offered was not in line with what the respondents expected.

Keywords: Media Advertising, Product Quality, Purchasing Decisions



INTRODUCTION

Information and communication technology is a crucial component of modern living. Today, it seems as though information and communication technology have advanced very quickly. You can imagine how slowly human life would move without information and communication technology as we know it today. As a result, ICT has enabled not only the smooth functioning of all elements of society, but also their rapid and dynamic evolution (Faeni, 2016).

According to O'Brien (2015), communication technology is an electronic system used for communication between individuals or groups. However, as demonstrated by Rubiyanto (2018), everything is connected via the use of tools for processing and transferring data from one device to another. The latter, following Robert and Jackson (2016), is the development and evolution of telecommunications and technologies that support the rapid delivery of information. In line with the definition of Robert and Jackson (2016), in this technological era, there are lots of media that provide information, including print media, social media, television, and others. These media can be accessed easily and without limits. Easily accessing unlimited information is one of the profit factors that can be utilized.

Communication technology is currently a serious issue for manufacturers and businesses that sell products and services because it influences consumer decisions when purchasing or using products and services. In communications technology, there is a medium that is becoming a cellular (radio) communication service called carrier medium.

One of his Indonesian telecom media operators is Indosat. Indosat is Indonesia's largest mobile operator. The trainer was also the first GSM mobile operator in Indonesia when he launched his postpaid Mentari card service on 26 May 1995, according to Indosat Grup data.

As previously explained, in this era of all technology, many people in Indonesia use operator services, and most of them are teenagers, with an age range of 19 to 24 years throughout Indonesia. They use this cellular operator not only to chat via SMS or telephone but to seek information. Therefore, network managers, especially Indosat, always strive to provide good service for the community or consumers so that they meet their consumers' mobile lifestyle needs.

According to Kotler and Armstrong (2016), when it comes to influencing both explicit and implicit desires, quality is described as the sum of a product's or service's defining qualities and properties. If there are certain products or brands that are of poor or poor quality, consumers will not choose these products for consumption, and this will allow consumers to switch to other products.

Sunyoto (2017) product quality shows the extent to which the product (service) meets specifications. Customers' perceptions of the company's commitment to quality, as evidenced by the products themselves, support the assertion that the prices are reasonable; the product's ability to have the best product quality in its products will strengthen the

position or position of the product in the minds of consumers so that it allows consumers to make the first choice when purchasing in the future. Kotler and Armstrong (2016), good quality will increase consumer confidence to continue to buy products produced by a company.

Every firm plans its operations to generate goods that will please its target market, with the understanding that doing so will bring in substantial profits over time (Amalia and Asmara, 2017). Companies do several ways to achieve success. The way that companies must do in order to achieve success in competition is to try to create and retain customers. Achieving this objective requires that businesses supply the items and services that customers want at a fair price that reflects the value they bring.

According to Tjiptono and Chandra (2017), "price perception" is "a consumer's assessment and related emotional forms of whether the price offered by the seller is reasonable and acceptable, both individually and in comparison to the prices offered by other parties." In addition, the price of a product or service reflects the value that buyers place on the numerous advantages they receive from purchasing and utilizing it. Customers consider cost as an important factor in buying purchases. In fact, for some shoppers, cost is synonymous with quality. Since pricing plays a part in consumer purchases (Purba, 2017), it's important to consider the market before settling on a final price.

One of Indosat's well-known products is IM3. IM3 is a cellular service owned by Indosat Ooredoo Hutchison. The service was launched in 2001 by Indosat-M3 as IM3 SMART and IM3 BRIGHT and was merged into Indosat at the end of 2003. As the name implies, IM3 has Unlimited Access to Instagram, Youtube, Chat, and Social Media without time limit. Large Quota on All Networks (2G, 3G, 4G) Free Calls and SMS to fellow IM3 Ooredoo and all operators and others for 24 hours. But before this, there was a time when IM3 starter packs came in many different packages. For example, the Simpati Loop card is specialized for young people and provides an internet connection, SMS, and calls at affordable prices. One of the cheap packages offered by Indosat is the unlimited internet package. By activating the Indosat Unlimited package, users can access the internet as much as they want without fear of their credit being deducted.

The diversity of products in existing providers encourages consumers to make identity in making decisions on a brand that they think meets the criteria of a product. This phenomenon results in increasingly fierce competition between providers, such as XL and Telkomsel.

Industry participants also feel and take advantage of the benefits of the expansion of information and communication technologies. Mobile telecommunications services are one industry that has developed as a direct result of the effects of the evolution of information and communication technology. In addition to its practical importance, today's ubiquitous information and communication technologies also present a promising commercial opportunity. The market for mobile phone service providers grows steadily each year. Furthermore, there is another evidence that the cellular operator sector is flourishing in Indonesia due to the rising demand for cellular phones. So it can be said that these two different business fields synergize with each other. Along with the high demand for cellular



phones, the development of the telecommunications industry in Indonesia is currently also growing rapidly. This can be seen from the emergence of several new providers that provide telecommunication services.

In Indonesia, there are two known networks that accommodate cellular telecommunication systems, namely Global System for Mobile Communication (GSM) and Code Division Multiple Access (CDMA). However, in terms of user population, the GSM network is more in demand due to its wider and better network quality. There are several GSM providers, such as Telkomsel, XL Axiata, Indosat, Hutchison, and Natrindo, while CDMA providers, such as Mobile 8, Others, Barkrie Tel, and Telkomflexi.

PT. Indosat is one of the cellular network service providers in Indonesia. PT. Indosat realizes and tries to create an effective marketing strategy. There are several marketing strategies used by PT Indosat, including advertising in print and electronic media, and sales promotions such as providing attractive package deals and providing rates according to needs.

PROBLEM FORMULATION

1. Does advertising have a positive effect on purchasing decisions?
2. Does sales promotion have a positive effect on purchasing decisions?
3. Does product quality have a positive effect on purchasing decisions?
4. Does price have a positive effect on purchasing decisions?
5. Does product quality have a positive effect on customer satisfaction?
6. Does the purchase decision have a positive effect on customer satisfaction?
7. Does customer satisfaction have a positive effect on customer loyalty?
8. Does the purchase decision mediate the effect of advertising, sales promotion, product quality, and price on customer satisfaction?
9. Does customer satisfaction mediate the effect of product quality and purchasing decisions on customer loyalty?

RESEARCH OBJECTIVES

1. To find out whether advertising has a positive effect on purchasing decisions.
2. To find out whether sales promotion has a positive effect on purchasing decisions.
3. To determine whether product quality has a positive effect on purchasing decisions.
4. To find out whether price has a positive effect on purchasing decisions
5. To determine whether product quality has a positive effect on customer satisfaction.
6. To find out whether purchasing decisions have a positive effect on customer satisfaction
7. To determine whether customer satisfaction has a positive effect on customer loyalty.
8. To determine whether purchasing decisions mediate the effect of advertising, sales promotion, product quality, and price on customer satisfaction.
9. To determine whether customer satisfaction mediates the effect of product quality and purchasing decisions on consumer loyalty.

RESEARCH BENEFITS

For Marketing Companies

Companies can use the findings of this study to better understand the impact of different marketing strategies on product sales, customer happiness, and loyalty. In addition, it is hoped that the findings of this study will be considered by company management when making decisions pertaining to marketing strategies, allowing for more effective and efficient implementation of such strategies, particularly for Indosat companies in the face of the increasingly fierce global business competition that exists today.

For Bhayangkara Jakarta Raya University

It is hoped that the results of this study can be used as input for other parties who want to conduct further research and as one of the reading materials that can add insight into the analysis of the influence of advertising, sales promotion, product quality, and price on purchasing decisions, satisfaction, and consumer loyalty.

For Researchers

The author can apply the knowledge gained during college, add insight into the field of marketing and consumer behavior, which can be used as a provision for entering the world of work later, and can share the results of research with interested parties in the future.

LITERATURE REVIEW AND HYPOTHESIS DEVELOPMENT

Framework of Thought

Based on the theories from previous research, it can be used as a basis for writing as well as a reference in building the author's framework. So it can be systematically described the relationship between the variables of Advertising, and Product Sales, to Product Quality in the research paradigm as follows.

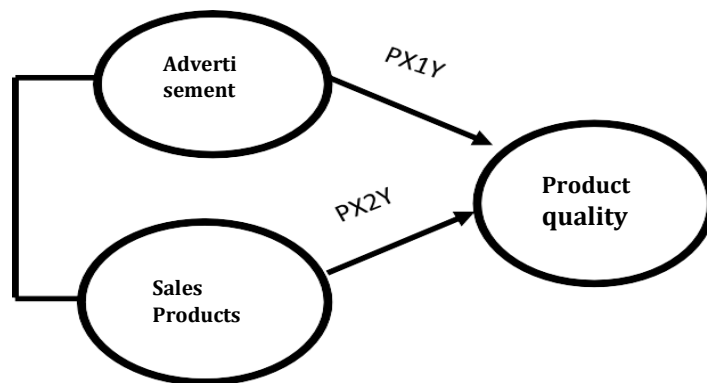

Figure 1. Frame of Thought

Hypothesis

Based on the description in the framework, the following hypothesis is prepared:

H 1: It is suspected that there is an effect of advertising on product quality.

H 2: It is suspected that there is an effect of product sales on product quality.

H 3: It is suspected that there is an effect of advertising and product sales on product quality.



RESEARCH METHOD

The objects in this study are students or employees spread across several schools or companies in the Jakarta area. This research was conducted on November 5, 2022, to February 5, 2023. Our research place is very flexible because we do online sampling, with the aim that respondents can fill out our questionnaire anywhere and anytime.

Research variables

This variable is divided into two research variables, namely: Independent Variables (Exogenous Variables)

Endogenous (dependent) variables can be influenced or even emerge as a result of changes in the independent variables. There are three external factors considered here, namely the effect of advertising (X1), product sales (X2), and product sales (X2).

Dependent Variable (Endogenous Variable)

The dependent variable is an endogenous variable. In statistical analysis, the independent (exogenous) variable influences or is the result of the dependent (endogenous) variable. Sales Quality (Y) is the endogenous dependent variable in this investigation.

Operational Variables

To equalize the understanding of the variables studied, it is necessary to explain the variables studied. The variables operationalized in this study are the variables contained in the hypothesis that has been formulated. Operations are based on the definition of characteristics that provide an overview of observations. Operational definitions often provide the information needed to measure the variables under study. Based on the theoretical studies that have been reviewed, the research components consisting of variables, dimensions, indicators, and instruments and the measurement scale used in this study are as follows:

Table 1: Variables, dimensions, indicators, and instruments and the measurement scale

VARIABLE	DIMENSIONS	INDICATOR	SCALE
Independent Variable (X)	Advertisement(X1)	1. Can cause attention 2. Attractive	Likert 1-5
Independent Variable (X)	Sales Products (X2)	1. Frequency of sales promotions. 2. Quality sales promotion. 3. Accuracy or suitability of promotional goalssale.	Likert 1-5
Dependent Variable (Y)	Product Quality(Y)	1. Product Performance 2. Durability 3. Compliance with specifications. 4. Reliability / reliability. 5. Perceived quality 6. Features (features)	Likert 1-5

Population and Sample

A population is a statistical grouping of things or people with a predetermined set of characteristics from which inferences can be drawn. According to this thinking, the population is the sum of all the variables, subjects, or items that make up the study. Any and all units of measurement, subjects, or entities in question. The sample represents a subset of the population with respect to size and distribution.

In this study, a total of 2950 employees were given a questionnaire; this number was derived through a random sampling of the population. The Slovin formula is used to calculate the sample size, with the following formula being used to estimate the total number of samples for this analysis.

$$n = \frac{N}{1 + N(e)^2}$$

Information:

- n : Number of samples
- N : Total population
- e : Error rate

From a total of 750 populations, (n) samples were obtained as follows:

$$n = \frac{2950}{1 + 2950(0,2)^2}$$

: 96,72 or rounded up to 100

This study used a sample size of 100 people. This study used a sample size of 100 people. Categories and Methods of Information Gathering. A questionnaire was used as a data gathering tool, with respondents being given a set of statements to choose from. The information for this study was gathered through a survey approach using a closed questionnaire that was broken down into two sections: the first contained statements to obtain respondents' personal data, and the second was used to obtain information about the dimensions of the building designed for this study, with respondents being asked to select one of several possible answers, some of which were intervals.

Model Fit Test To assess whether the data collected is consistent and in accordance with the model, a model fit test is conducted. If the model does not fit the data, it is necessary to look for the cause in the model and find ways to modify the model to get a better fit for the data. According to Goodness Of Fit, a valid and good model is one that adequately describes the data. The following table provides a concise overview of the PLS model measurements.

Table 2. Model fit test

Measurement Models	Criteria
SRMR	< 0.08 (Henseler, 2014)
NFIs	> 0.90 (Lohmöller, 1989)
rms Theta	< 0.12 (Lohmöller, 1989)

Source: Smart PLS Gozali book, 2015



Research Instrument Tests were carried out on valid statements. The level of validity and reliability can be seen from the quality of the data obtained. Furthermore, the criteria used to determine a statement can be said to be valid and has an acceptable reliability value.

Table 3. Rule of Thumb Evaluation of the Measurement Model (Outer Model)

validity	Parameter	Rule of Thumb
Convergent Validity	<i>Loading factor</i>	<ul style="list-style-type: none"> • > 0.70 for confirmatory research • > 0.60 for exploratory research
	<i>Communality</i>	<ul style="list-style-type: none"> • > 0.50 for confirmatory and exploratory research
	AVE (Average Variance Extracted)	<ul style="list-style-type: none"> • > 0.50 for confirmatory and exploratory research
Discriminant Validity	Cross Loading	<ul style="list-style-type: none"> • > 0.70 for each variable
	Ave square root and correlation between latent constructs	Square root AVE > correlation between latent constructs

Validity test

When a measuring device accurately provides information about the phenomenon being studied, we say that the device is legitimate. Invalid measurement scales are of little use to researchers since they do not provide accurate readings. Small error variance indicates that the test is measuring what it claims to be measuring and is delivering results that are in line with its intended use. In order to ensure the accuracy of the information gathered. How well a measuring device achieves its intended results is illustrated by its validity (Kuncoro, 2003).

Reliability Test

If the data collecting instrument exhibits the same level of precision, accuracy, stability, or consistency in exposing particular symptoms from a group of persons despite being carried out at different periods, then we may say that it has passed the reliability test. If repeated measurements of the same symptom with the same measuring tool yield the same results, we say that the tool is dependable (Nasution, 2003).

Table 3.4 from the Outer Model Evaluation Rule of Thumb specifies that Cronbach's alpha > 0.7 and composite reliability > 0.5 as indicative of a reliable construct.

RESEARCH RESULT

Evaluation of the Measurement Model (outer model)

The link between variables/constructs and their indicators is assessed through measurement model evaluation. The SmartPLS Software's PLS Algorithm process yields the measurement model needed to verify the equation model's accuracy; the algorithm's output is displayed in Figure 1.

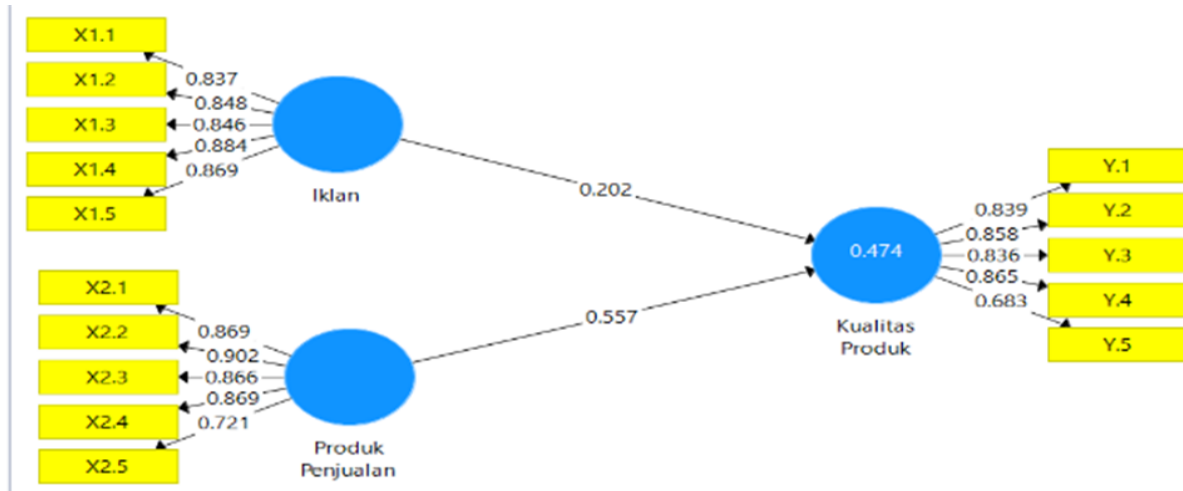

Figure 1. Figure outer model

Convergent validity and discriminant validity are two measures of validity that can be used with SmartPLS 3.0. The value of the loading factor is a measure of convergent validity, while the AVE, the square root of the AVE, and the cross-loadings are measures of discriminant validity.

Table 4. Convergent validity test (Loading factor).

Declaration Number	Test result	Validity Description
Advertising Statement		
X1.1	0.837	Valid
X1.2	0.848	Valid
X1.3	0.846	Valid
X1.4	0.884	Valid
X1.5	0.869	Valid
Sales Product Inquiries		
X2.1	0.869	Valid
X2.2	0.902	Valid
X2.3	0.866	Valid
X2.4	0.869	Valid
X2.5	0.721	Valid
Product Quality Confidence		
Y. 1	0.839	Valid
Y.2	0.858	Valid
Y.3	0.836	Valid
Y.4	0.865	Valid
Y.5	0.683	Invalid

Table 4's convergent validity test results reveal that the indicator is valid, with a value greater than 0.5, allowing the data to be processed without error.

Table 5 Average Variance Extracted (AVE) Value

Variable/Construct	Average Variance Extracted(AVE)(>0.5)
Advertisement(X1)	0.734
Sales Products(X2)	0.671
Product quality(Y)	0.719

In Table 5 it can be seen that the AVE value of each variable is above 0.5 so that it can be said to be discriminantly valid based on AVE.

Table 6. Reliability Testing Results for Each Variable.

Variable/Construct	Test result		Reliability Description
	Cronchbach's Alpha	Composite Reliability	
Advertisement(X1)	0.910	0.915	Reliable
Sales Products(X2)	0.900	0.905	Reliable
Product quality(Y)	0.875	0.884	Reliable

Cronbach's alpha values for all variables in Table 6 are above 0.7, and composite reliability values for all variables are over 0.5, indicating that all constructs in this study can be relied upon.

Evaluation of the Structural Model (Inner Model)

Testing the research model's internal structure is done to examine the importance of the variables and constructs in the model.

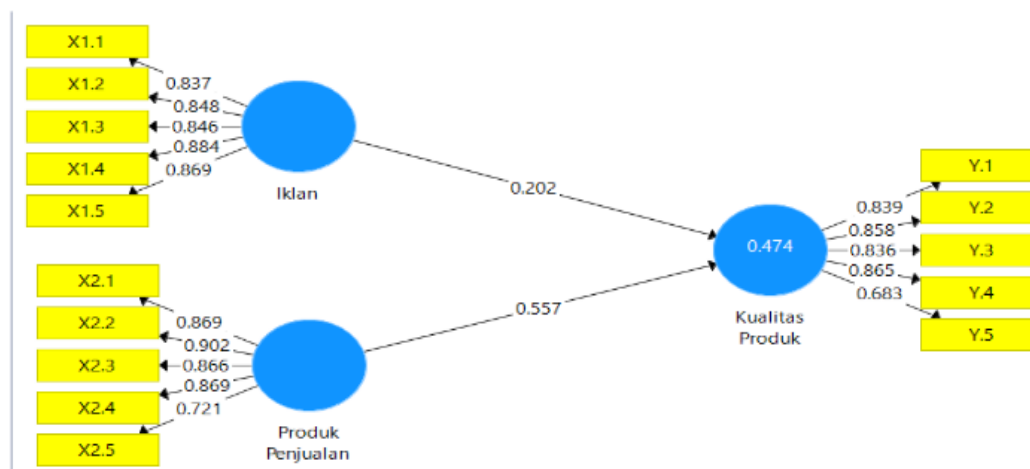

Figure 2. Figure Inner Model

Accounting Inquiries with New Approaches in the Post-Pandemic Era
Volume I

Table 7. Significance Test Results

Variable/ Construct	Indicator		<i>T-Statistics</i>	P-Values	Description of Significance
<i>Advertisem ent (X1)</i>	X1.1	Indosat advertisements always provide information new product.	16,885	0.000	Significant
	X1.2	Messages conveyed in Indosat advertisements able to arouse my desire to know more about Indosat products.	18,076	0.000	Significant
	X1.3	I think Indosat ads are easy to remember	21,797	0.000	Significant
	X1.4	The message conveyed in the Indosat advertisement was able to influence my decision in determine which provider to use.	33,987	0.000	Significant
	X1.5	I think Indosat ads are always make a good impression	29,115	0.000	Significant
<i>Sales Products (X2)</i>	X2.1	Indosat products have good quality	27,382	0.000	Significant
	X2.2	Indosat provider quality in accordance with which are expected.	31,070	0.000	Significant
	X2.3	Indosat products can be accepted in all circles	29,631	0.000	Significant
	X2.4	The price of the product offered isin accordance with the quality of the product	29,315	0.000	Significant
	X2.5	The price offered by Indosat is cheaper than competitors	12,259	0.000	Significant
Variable/ Construct	Indicator		<i>T-statistics</i>	P- Values	Description of Significance
<i>Product Quality (Y)</i>	Y. 1	I bought the Indosat provider because of the different variantsdraw attention	26,068	0.000	Significant
	Y.2	I bought Indosat products because already know the benefits that areoffered by other providers.	28,395	0.000	Significant
	Y.3	I bought Indosat products because there are already a lot ofthem known in the eyes of society	23,511	0.000	Significant



	Y.4	I bought Indosat products because I have compared with other providers.	27,067	0.000	Significant
	Y.5	I'm looking for information about Indosat products from advertisements, official websites, and from dealers.	7,812	0.000	Significant

The table shows that all of the T-statistic indicators are greater than 1.96, indicating that all indicators of the variables of school infrastructure, teacher quality, and pedagogical approach are statistically significant.

Table 8. Significance Test Results from Variable to Variable (Inner Model)

Variable/Construct	<i>t</i> -statistic	P-Values	Description of Significance
Advertising -> Product Quality	1,384	0.167	Significant
Product Sales -> Product Quality	4,884	0.000	Significant

Table 4.12 shows that the t-statistic for Advertising and Sales Products is significantly higher than the significance threshold for the Rule of Thumb Evaluation of the Measurement Model (Outer Model) table in Table 5. This suggests that Advertising and Sales Products and Compensation both significantly impact employee performance.

Table 9. Model fit test

Measurement Models	Criteria	Test result	Information
SRMR	< 0.08 (Henseler et. al, 2014)	0.063	Fit models
NFIs	> 0.90 (Lohmöller, 1989)	0.884	Fit models
rms Theta	< 0.12 (Lohmöller, 1989)	0.613	Fit models

Based on the test results in Table 4.13, it is known that the SRMR, NFI, and rms Theta values meet the specified criteria which means that the data collected is consistent and fits the model according to the Goodness of Fit.

Hypothesis test

The original sample value of the route coefficient reveals the relative strength of each exogenous variable's influence on the endogenous variable. The exogenous variable has a positive effect on the endogenous variable if and only if the initial sample value is positive.

Table 10. Original Samples

Variable/Construct	Original Sample
Advertisement (X1)	0.202

<i>Product Quality (X2)</i>	0.557
-----------------------------	-------

Table 4.14 demonstrates that all variables have positive values. The impact of advertising compensation on employee performance is 0.202, while the impact of product quality is 0.557.

Table 11. R Square and Adjusted R Square

Endogenous Variables	R Square	Adjusted R Square
Product quality (Y)	0.474	0.463

Analysis of the data shows that Employee Performance has an R-squared value of 0.120. The coefficient of determination, which can be derived from the R-squared value, reveals the extent to which independent variables are influenced by the independent ones.

- H1: There is no conclusive evidence that advertising improves productivity in the workplace. Table 4.12 displays the results of a test of the hypothesis that there is a relationship between the Advertising concept and Employee Performance. The path coefficient for the Original Sample is 0.202. The T-statistic is 0.528 1.64, and the P Values are 0.597 > 0.05. The findings of this study support the alternative hypothesis (H1) and negate the null hypothesis (H0), leading the researchers to the conclusion that human advertising does not have a statistically significant beneficial influence on worker performance in the Jakarta area.
- H2: Employee performance is significantly improved by higher pay. Table 4.12 shows that the effect of product sales on employee performance is statistically significant, with a T-statistic of 3.669 > 1.64 and a P-value of 0.000 < 0.05, indicating a path coefficient value of 0.557 in the Original Sample. The results of this study support the third hypothesis and reject the null, leading us to the conclusion that pay directly affects productivity.

CONCLUSION AND RECOMMENDATION

Conclusion

The following inferences can be made about how trust, pricing, and promotion influence consumers' preferences when utilizing the Indosat service:

1. Trust partially has a positive and significant effect on purchasing decisions.
2. Price partially has a positive and significant effect on purchasing decisions.
3. Promotion partially has no significant effect on purchasing decisions.
4. Trust, Price, and Promotion have a simultaneous effect on Purchasing Decision Variables

Suggestion

Based on the research and some of the conclusions above, suggestions can be drawn regarding the influence of trust, price, and promotion on purchasing decisions for Indosat providers in the Jakarta community, as follows:

1. The results of the research that have been conducted show that the trust variable is the dominant variable in influencing purchasing decisions. Therefore it is hoped that Indosat management will maintain and continue to maintain service convenience in



internet network speed so that the decision to purchase internet quota in the MyIM3 application will increase.

2. Indosat is expected to pay more attention to promotions on the MyIM3 Application, considering that in this study, the effect of the promotion variable is the lowest compared to other variables because, based on the theory and hypothesis of previous research, purchasing decisions will increase with good and targeted promotions.
3. Indosat management is also expected to always improve and provide new breakthroughs where to further refine the independent variables that have been studied or other factors outside of this study so that they can find out more about consumer desires or expectations regarding their decisions to make purchases on the MyIM3 Application, and routinely conduct surveys by responding to criticism and suggestions from consumers so that they can get input from consumers and can improve what is still lacking in the MyIM3 Application in order to improve purchasing decisions on the MyIM3 Application.
4. This study found that trust, price, and promotion accounted for 52.3% of the total effect on purchasing decisions, while product quality, application design, personal factors, functions, and others accounted for the remaining 47.7%. Future research would benefit from including additional variables that can influence purchasing decisions.
5. For further research using more respondents, you should determine the area to narrow the population of respondents to make it easier to collect data

REFERENCES

- Abdillah, Willy and Jogyanto Hartono. 2018. Partial Least Square (PLS)- Alternative Structural Equation Modeling (SEM) in Business Research. Jakarta: Andi Offset.
- Abdurrahman, Nana Herdiana. 2018. Marketing Strategy Management. Bandung: CV. Faithful Library.
- Adisaputro, Gunawan. 2014. Marketing Management: Analysis for Design Marketing strategy. Jakarta: UPP STIM YKPN.
- Dawn, Laksana. 2008. Marketing Management. Yogyakarta: Science Graha.
- George E. Belch & Michael E. Belch. 2001. Advertising and Promotion: An Integrated Marketing Communication Perspectives. Fifth Edition. New York: Irwin/Graw Hill.
- Faeni, Dewi Puspaningtyas. (2015). HRM Practices and Existence of Knowledge Management Agent in Higher Education, Information and Knowledge Management, 5(3) 2224-5758. <https://www.iiste.org/Journals/index.php/IKM/article/view/20581>
- Faeni, Dewi Puspaningtyas., Ratih Puspitaningtyas Faeni, (2016) Cognitive Style and Composition of Employees in Shaping Intellective Sales Team. Business Economig Social Science Humanities Conference (BESSH). Volume 11. September 2016.. Willey Publisher.
- Faeni, Dewi Puspaningtyas., Ratih Puspitaningtyas Faeni, (2016) Manager Characteristics, HR Renewal, Marketing Strategies, Partnership Motivation, Work Orientation, Work Standardization, on SMES Business Resilience in the Competition: Insurance Healthcare Services. Scholedge International Journal of Management & Development Volume 3, Issue 2. Pages 32-48 Publisher. Scholedge the Scholarly Publishing
- Faeni, Dewi Puspaningtyas., Ratih Puspitaningtyas, (2020) The Role Of Management Control System On Firm Performance. Talent Development & Excellence, 12(1), 1629-1639. <http://www.iratde.com/>
- Faeni, Dewi Puspaningtyas., Ratih Puspitaningtyas, Yuliansyah Yuliansyah. (2022). The COVID-19 Pandemic Impact on the Global Tourism Industry SMEs: A Human Capital Development Perspective. Review of International Business and Strategy, 32(4), 2059-6014. <https://doi.org/10.1108/RIBS-08-2021-0116>
- Faeni, Dewi Puspaningtyas., Yudi Nugroho. (2017) The Role Of Women Entrepreneurs Leadrships, Social Capitaland Absorptive Capacity Through Skills Upgrading Concept In Small To Medium Enterprises In Jakarta, Indonesia. International Journal of Pure and Applied Mathematics, 116(24), 511-520. <http://www.ijpam.eu/>

**Accounting Inquiries with New Approaches in the Post-Pandemic Era
Volume I**

- Griffin, Jill. 2003. *Customer Loyalty: Growing and Maintaining Customer*. Revised and Latest Edition. Jakarta: Erlangga.
- Herman, Agus. 2012. *Marketing Communications*. Jakarta: Erlangga.
- Indosat (Case Study on Indosat in the Semarang Region). Semarang: Diponegoro University.
- Kotler, Philip & Keller. 2009. *Marketing Management*. Edition 13. Volume 1. Jakarta: Erlangga.
- Kotler, Philip and Gary Armstrong. 2003. *Fundamentals of Marketing*. Issue 9. Vol 1 Jakarta: PT. Index.
- Kotler, Philip and Gary Armstrong. 2008. *Marketing Principles*. 12th Edition. Volume 1. Jakarta: Erlangga Publisher.
- Kotler, Philip. 1985. *Fundamentals of Marketing*. Second Edition. Jakarta: CV. Intermedia.
- Kotler, Philip. 2000. *Marketing Management*. New Jersey: Prentice-Hall, Inc. Kotler, Philip. 2005. *Marketing Management*. Edition 11. Volume 1. Klaten: PT. Index.
- Kuncoro, Mudrajad. 2013. *Research Methods for Business & Economy*. Jakarta: Erlangga.
- Martono, Nana. 2014. *Quantitative Research Methods*. Jakarta: PT Raja Grafindo Homeland.
- Morrisan. 2010. *Advertising: Integrated Marketing Communication*. Jakarta: Kencana
- on Consumer Satisfaction to Increase Consumer Loyalty
- Prahastuti, Lina. 2011. "Analysis of the Influence of Service Quality and Product Quality
- Prasetyo, Bambang and Miftahul Jannah. 2005. *Quantitative Research Methods*. Jakarta: PT Raja Grafindo Persada.
- Sholihin, Mahfud and Dwi Ratmoko. 2013. *SEM-PLS Analysis with WarpPLS 3.0*. Yogyakarta: Andi Offset.
- Simamora, B. 2008. *Consumer Behavior Research Guide*. Jakarta: PT Gramedia Main Library.
- Suharso, Puguh. 2009. *Quantitative Research Methods for Business: Approaches Philosophy and Practical*. Jakarta: PT. Index.
- Sumarwan, Ujang. 2011. *Consumer Behavior: Theory and Its Application in Marketing*, Second Edition. Bogor: Ghalia Indonesia.
- Supranto, J and Nandan Limakrisna. 2007. *Consumer Behavior and Strategy Marketing: To Win Business Competition*.
- Yunita, A. and Jony Oktavian Haryanto. 2012. "The Effect of Word of Mouth, Advertising and Product Attributes on Purchase Decision and Loyalty Consumers (Case Study on Magnum White Chocolate Consumers)", *Journal of Technology Management*. Salatiga: Satya Wacana Christian University.

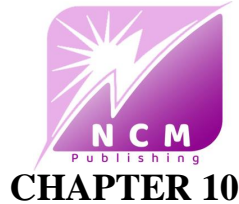

Maritime Sector for National Economy (Competitiveness) Through Connectivity: A Systematic Literature Review Analysis

Muhammad Zilal HAMZAH

Trisakti University
mhd_zilal_hamzah@trisakti.ac.id

Eleonora SOFILDA

Trisakti University
eleonora@trisakti.ac.id

EFEREDO

Trisakti University
eferedo31@gmail.com

ABSTRACT

Increasing the competitiveness level is coveted by every country because it can give more public benefit. However, these are commonly resulting the trade-off between those. Indonesia as an archipelagic country that relayed on the maritime sector for the distribution of goods should focus on connectivity for each region to develop the whole economy, but there are many ways to achieve connectivity through maritime sectors. Therefore, this study aims to identify how the maritime sector can affect the national economy and its implication for Indonesia Government. This study will use the Systematic Literature Review (SLR) method with the Preferred Reporting Items for Systematic Review and Meta-Analysis (PRISMA). Moreover, this study using Bibliometric Analysis (Keyword) and Word Frequency for further analysis. There are 57 eligible articles which use for further analysis. According to analysis, the main finding of this study is the maritime sector can play an important role in the national economy by increasing its competitiveness. Moreover, the development of infrastructures can be used for government to enhance the competitiveness. Maritime sector can generate more competitiveness through its connectivity and it implies for Indonesia's Foreign Direct Investment (FDI). So that the government should put more focus to create more connectivity in achieving higher competitiveness through the development of infrastructures. This result can be used for government as an input for macro policy.

Keywords: Maritime, Competitiveness, Connectivity, Infrastructure, SLR

INTRODUCTION

Increasing the competitiveness level is coveted by every country because it can give more public benefit. Every sector in the economy has a strategy to achieve its objectives, especially in the Maritime sector. This sector plays a crucial role in an archipelagic country like Indonesia. There are several isolated areas in Indonesia that difficult to be reached (known as 3TP Area). This area is mostly distributed in the East of Indonesia. So that the East Indonesia had a difference price compared to the West. The following figure will show the price disparity among them:

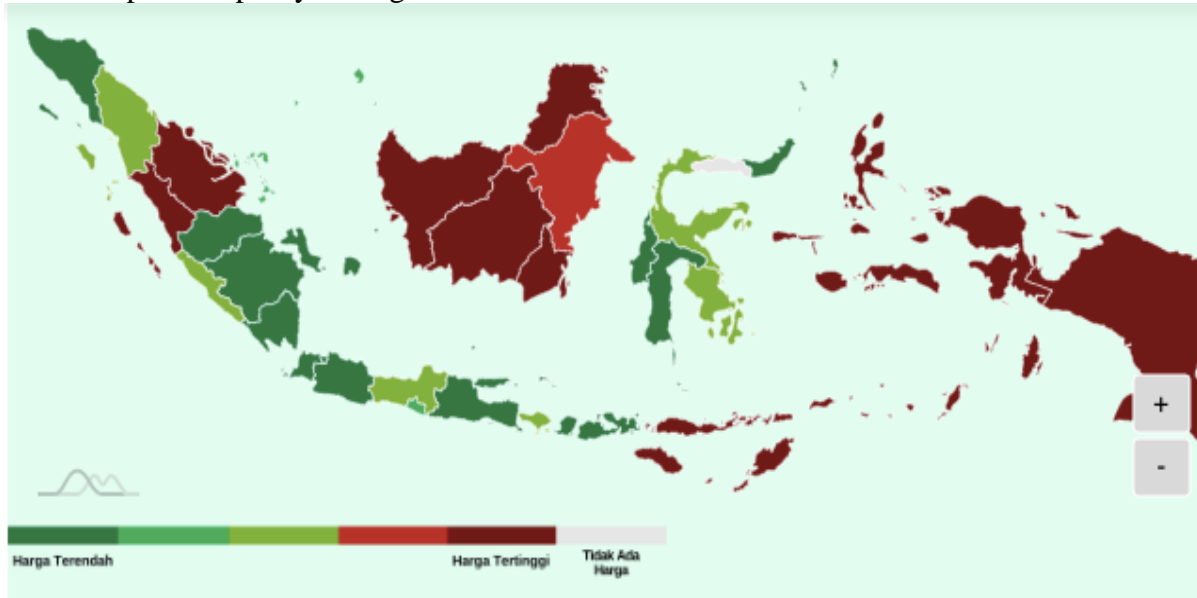

Figure 1. Price Disparity Map in Indonesia

The figure above illustrates the price disparity in Indonesia where there are still differences, especially in the Eastern regions. As shown above, the eastern regions of Indonesia still have high price levels, even though there have been changes for the better than before. This indicates that there is still work for the transportation sector, especially the sea, in Indonesia to continue to try to reduce the price disparity that occurs between the western and eastern regions of Indonesia.

This problem can be solved through the existence of modes of transportation, especially sea transportation mode. This mode of transportation is part of the maritime ecosystem that can contribute to the whole economy. The contribution to GDP for the maritime sector is still relatively small compared to the other sectors that around 5% each year (Indonesia Bureau of Statistics, 2022). This mode plays an important role in the flow of goods or as a choice of public transportation modes. *Peraturan Presiden Republik Indonesia No. 70 tahun 2017* concerning Implementation of Public Service Obligations for the Transportation of Goods to and from Disadvantaged, Remote, Outermost, and Border Areas which aims to achieve the target of reducing price disparities as stated in the 2015-2019 national medium-term development plan which aims to ensure the availability of goods and increase the welfare of the people and the continuity of services for the organization of goods transportation to and from underdeveloped, remote, outermost and border areas. Given the characteristics of Indonesia, which is an archaic country, one of the most important and superior modes of transportation is sea transportation. These modes play an important role in the flow of goods or as a choice of public transportation modes.

One of the Government's Program to connect each region is Sea Toll. Since 2015, the government has determined 6 (six) routes which are contained in the Decree of the Director General of Sea Transportation Number AL.108/6/2/DJPL-15 concerning Network



Routes for the Implementation of Public Service Obligations for Transportation of Goods in the Context of the Implementation of the Sea Toll Fiscal Year 2015. The government (Ministry of Transportation), assigned PT. Pelindo (Persero) that is contained in Presidential Regulation Number 106 of 2015 concerning the Implementation of Public Service Obligations for the Transportation of Goods in the Context of the Implementation of the Sea Toll which was followed by the issuance of Minister of Transportation Regulation Number PM. 161 of 2015 dated 16 October 2015 concerning the Implementation of Public Service Obligations for the Transport of Goods at Sea and Regulation of the Minister of Transportation Number 168 of 2015 concerning Tariffs for Domestic Goods Transport and Loading and Unloading in the Context of the Implementation of the Sea Toll. Therefore, it can be said that the Sea Toll program is designed in such a way that is also aimed at improving the quality of the level of connectivity between regions in Indonesia.

An efficient and quality physical connectivity network is a key factor in achieving the intended goal. The physical connectivity in question can include roads, railways, ports and airports as well as reliable and efficient digital connectivity networks so that distribution to inter-island areas is easy. The function of monitoring and enforcing shipping safety regulations carried out by the Ministry of Transportation will be felt to be even more difficult if progress in the use of sophisticated technology is not matched by an increase in the competence of Human Resources (HR). Ivosevic (2021) using a mixed approach also found that the HR aspect is vital for the maritime sector. Therefore, technology development must be followed by development in terms of the quality of human resources who will use it.

Although this sector still has a small contribution, however, it plays a crucial role in goods distribution. This sector has been contributing to a decrease in price disparity in Indonesia, especially in the east region (Indonesia Ministry of Trade, 2022). So that this sector plays a crucial role in the Indonesian economy.

The connectivity for each region is the main factor that can contribute to boosting the region's economy. It implies that trade openness for each region can help to smooth the distribution of goods. Not only for development, but this factor also can contribute to boosting competitiveness to attract more investment (capital inflow). The study carried out by Ly (2021) who identified the connection between Foreign Direct Investment (FDI) and the connectivity aspect found that the two aspects have a significant relationship in Cambodia. The role of transportation or infrastructure in the economy is found as the main factor to attract FDI. Ng et al. (2019) in their study showed that the infrastructure of transportation can generate more economic growth. Moreover, Pradana & Bagchib (2013), Peter et al. (2015), Wang et al. (2020), and Banerjee et al. (2020) also found a similar result. It implies that the transportation infrastructures are the support component to achieve better connectivity. For the comparison, the following data shows the quality of transportation infrastructure in East Asia countries measured by Global Competitiveness Index:

Accounting Inquiries with New Approaches in the Post-Pandemic Era
Volume I

Country	Quality of overall infrastructure	Quality of roads	Quality of railroad infrastructure	Quality of port infrastructure	Quality of air transport infrastructure	Quality of electricity supply
China	51	42	16	50	51	53
Japan	7	8	1	22	25	21
Republic of Korea	20	17	10	27	28	38
Taiwan, China	21	10	11	19	26	28
Hong Kong SAR	3	5	3	5	3	2
Singapore	4	3	8	2	1	3
Malaysia	16	15	13	16	21	36
Brunei Darussalam	39	35	n/a	49	55	59
Indonesia	81	80	43	82	66	86
Thailand	71	51	78	52	38	56
Vietnam	99	93	48	76	75	87
Cambodia	102	94	100	83	100	108
Lao PDR	78	83	n/a	130	94	72
Philippines	106	97	84	103	98	89
Myanmar	135	136	96	123	132	118

Figure 2. Infrastructure Performance of East Asia Countries 2015-2016

According to the data above, by the Port Infrastructure quality, Myanmar and Cambodia are the countries that have a highest performance. However, Indonesia experienced a moderate performance. Moreover, Indonesia placed 62th behind Malaysia (24th) and Thailand (44th). The following figure shows the overall global competitiveness in East Asia countries:

Country	Overall Global Competitiveness Index 2015–2016		GDP per capita (US\$)	Global Competitiveness Index 2015–2016 (rank out of 140)		
	Rank (out of 140)	Score (1–7)		Institutions	Infrastructure	Innovation
Singapore	2	5.7	56,319	2	2	9
Japan	6	5.5	36,332	13	5	5
Hong Kong SAR	7	5.5	39,871	8	1	27
Taiwan, China	15	5.3	22,598	27	12	11
Malaysia	18	5.2	10,804	23	24	20
Republic of Korea	26	5.0	28,101	69	13	19
China	28	4.9	7,589	51	39	31
Thailand	32	4.6	5,445	82	44	57
Indonesia	37	4.5	3,534	55	62	30
Philippines	47	4.4	2,865	77	90	48
Vietnam	56	4.3	2,053	85	76	73
Lao PDR	83	4.0	1,693	71	98	108
Cambodia	90	3.9	1,081	111	101	122
Myanmar	131	3.3	1,221	133	134	132

Figure 3. Overall Global Competitiveness of East Asia Countries 2015-2016



According to the Figure 3, the most competitive countries by Institutions, Infrastructure, and Innovation are placed by Singapore, Japan, and Hong Kong SAR. Enhancing connectivity by addressing both hard and soft component are the key factors to achieve a closer cooperation and integration. However, it constitutes the most difficult part of a regional integration process that will require enormous amounts of long-term investment (Yu, 2017). Because the transportation sector plays a crucial role in the economy, therefore this study aims to identify qualitatively how the mode of transportation in which sea transportation (maritime sector) can contribute to the national economy and gives an implication for the Indonesian Government. According to Pradana & Bagchib (2013), Peter et al. (2015), Ng et al. (2019), Wang et al. (2020), and Banerjee et al. (2020) these studies using a different approach to analyze the contribution of the maritime sector (transportation) for the economy and resulting a new recommendation for the government. Therefore, it can be a different one compared to the previous stated.

THEORETICAL REVIEW

This study is relevant for public policy studies because it focuses to generate a policy recommendation for Maritime Sector. Birkland (2019) defines public policy into several definitions: (i). Public policy is made in response to some sort of problems and that deserves some sorts of government response; (ii). Public policy is made in the public interest, because not everyone will agree on the public interest; (iii). Policy is interpreted and implemented by public and private actors who have different motivations, and therefore will bring different interpretation of problems and solutions; (iv). Public policy is oriented toward a goal or desired state, such as reducing the incidence or severity of several problems; and (v). Policy is made from governments even the ideas come from the outside or through the interaction between government and non-governmental actors. Moreover, Anderson (1997) argues that public policy is a targeted and relatively consistent action carried out by one or several specific actors who focus or concentrate on a problem. Dye (2013) ranks the stages of the public policy process, such as: (i). Problem identification; (ii). Agenda setting; (iii). Policy formulation; (iv). Policy legitimacy; (v). Policy implementation; and (vi). Policy evaluation. It can be concluded that public policy is a series of actions generated by the government with a certain process to achieve a predetermined goal. There are some of sort Indonesian Maritime rules/policies which has been implemented: (i). The Decree of the General Directorate of Sea Transportation No. AL.108/6/2/DJPL-15 concerning Network Routes for the Implementation of Public Service Obligations for Transportation of Goods in the Context of the Implementation of the Sea Toll Fiscal Year 2015; (ii). Minister of Transportation Regulation No. 161 of 2015 dated 16 October 2015 concerning the Implementation of Public Service Obligations for the Transport of Goods at Sea; (iii). Regulation of the Minister of Transportation Number 168 of 2015 concerning Tariffs for Domestic Goods Transport and Loading and Unloading in the Context of the Implementation of the Sea Tol; and so on. Implementation of Sea Toll started since 2015 with two main component aspect: (i). Sea transportation subsidy for reducing price disparity especially for isolated area; and (ii). The development of backbone network that connect the logistic to another area. The implementation of Sea Toll policy can be seen as a government effort to connect each region and to develop the areas.

The transportation system is part of the logistics system that functions as a supporting aspect in the process of moving goods. The following figure (Figure 1) which

shows how the role of transportation in a single logistics system according to (Rushton et al., 2010):

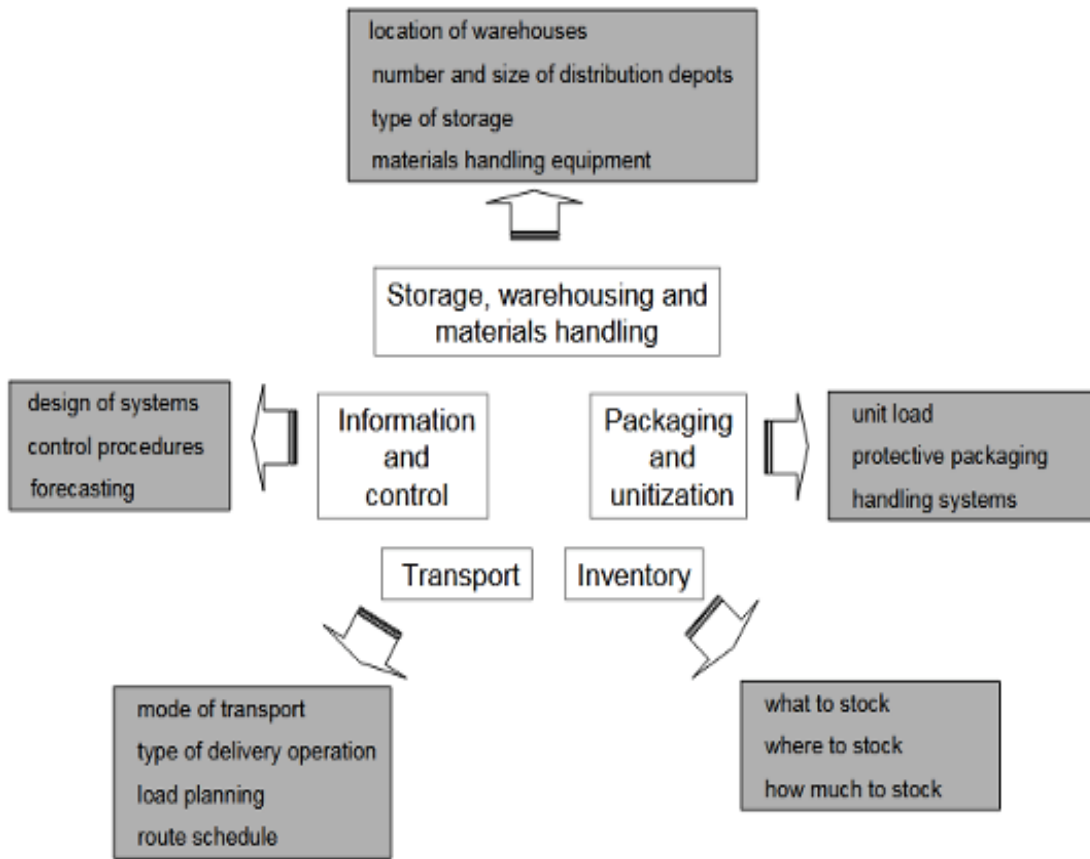

Figure 4. Distribution & Logistics System

According to that figure, there are transportation aspects in the logistics system which include modes of transportation, loading and unloading plans, types of shipping operations schedules, and routes. Putra et al. (2019) argue that the connectivity system is needed for supporting the region economic development. Moreover, the sea transportation is supported by the port as the main element for connectivity. Rodrigue & Comtois (2013) show the 4 function of intermodal transportation that consist composition, interchange, and decomposition.

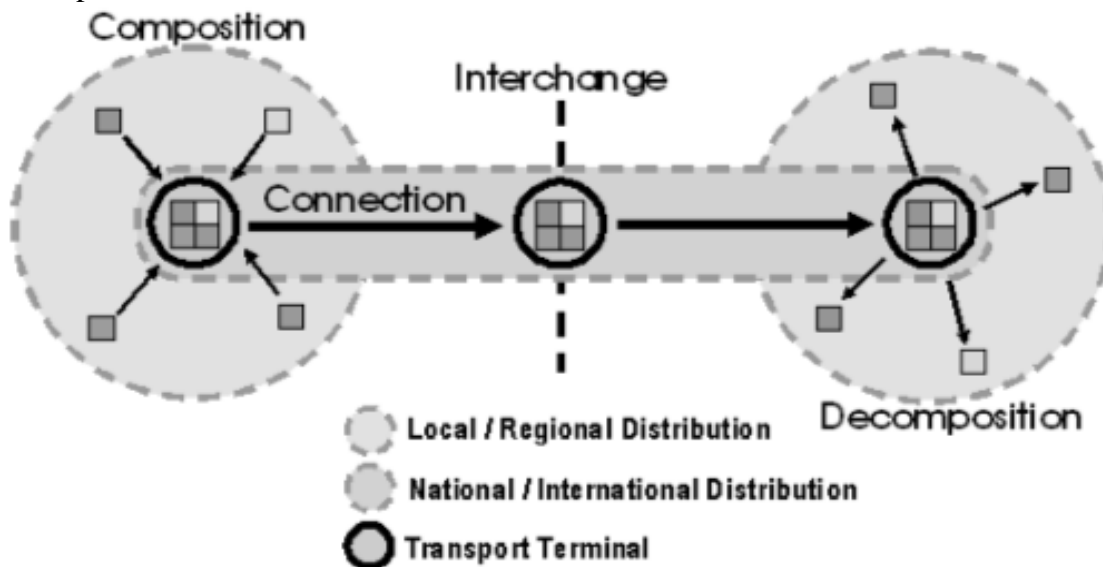

Figure 5. Intermodal Transportation Chain



Moreover, many studies have been carried out all over the world about transportation or connectivity aspects. For example, Pradana & Bagchib (2013), Peter et al. (2015), Wang et al. (2020), and Banerjee et al. (2020) in their study found that the infrastructure of transportation (connectivity) can significantly affect the whole economy. Seker (2020) argue that shipping connectivity index and economic growth have a positive effect on the exports in European countries and Turkey. 1% increase in liner shipping connectivity index provides the increment 0.21% in the exports. Chen et al. (2019) in their study also conclude that connectivity can contribute to economic growth in Belt and Road Countries. Moreover, Palei (2015) showed that national competitiveness is influenced basically by infrastructure (quality of roads, railroad infrastructure, air transport, and electricity supply). There are several studies distributed across the country to see the effect of transportation infrastructure (connectivity) on the economy such as: Hillebrandt (2000); Dubois & Gadde (2002) in Developed Industrial Countries. Chan & Tse (2003) in Australia, Dikbas & Akkoyun (2006) in EU countries, Akiner and Akiner (2009; 2018) in Turkey; and Altar-Tur et al. (2016) in Spain. The physical infrastructure contributes for fluent stream of goods, services, capital, technology, and human capital. According to Yu (2017) the physical infrastructure divided by two components are hard and soft component. The hard component consists of highway, railway, port, airport, electricity, energy supply, and technology. Furthermore, the soft component consists of organizational rating, trade facility mechanism, trade policy, investment, efficient customs administration, and so on. Seeing of another problems in maritime sectors, Martono (2019) argue about several problems founded in ASEAN Maritime sectors: (i). Lack of logistics literacy: unproductive use of printed and written information about logistics to develop personal knowledge and potential, to increase productivity, and to make decision; (ii). Logistics divide: Logistics Performance Index (LPI) in ASEAN is fragmented; (iii). Gap in the stock of human capital in logistics across ASEAN's countries: years of education, years of training, gender disparity, level of competence, level of salary, and training access and affordability; (iii). Health, safety, and security problem; (iv). Enviromental degradation including carbon emission problem; (v). Hazardous material handling and toxic waste problem; (vi). Corruption problems: criminal prosecution for bribing a government contracting officer; (vii). Unethical and misconduct behavior of logisticians: fraud and emblezzlement and financial mismanagement; (viii). Failure to meet and follow quality standards and procedures; and (ix). Lack of reliable partnerswho demonstrate integrity and operate on a transparent basis.

METHODOLOGY

The aim of this study is to identify how the maritime sector can affect the national economy. Furthermore, the qualitative approach with a modified Systematic Literature Review (SLR) technique is involved. The data that are used in this study were collected through Publish or Perish by Harzing. This study will generate articles from journals indexed by Scopus and Web of Science (WOS) simultaneously. The search processes will include certain keywords such as: Manpower Policy, Labor & Environmental Sustainability, and Sustainable Development. Filtering articles will use a PRISMA flow chart diagram. PRISMA is commonly used for Meta-Analysis. However, this study doesn't work with Meta-Analysis. The eligible articles chosen will be analyzed using VOS Viewer to run bibliometric analysis and NVivo to code each article. These steps are commonly

called methods of triangulation (Sutopo, 2016). To see the research design comprehensively, here is the related figure to show the research design:

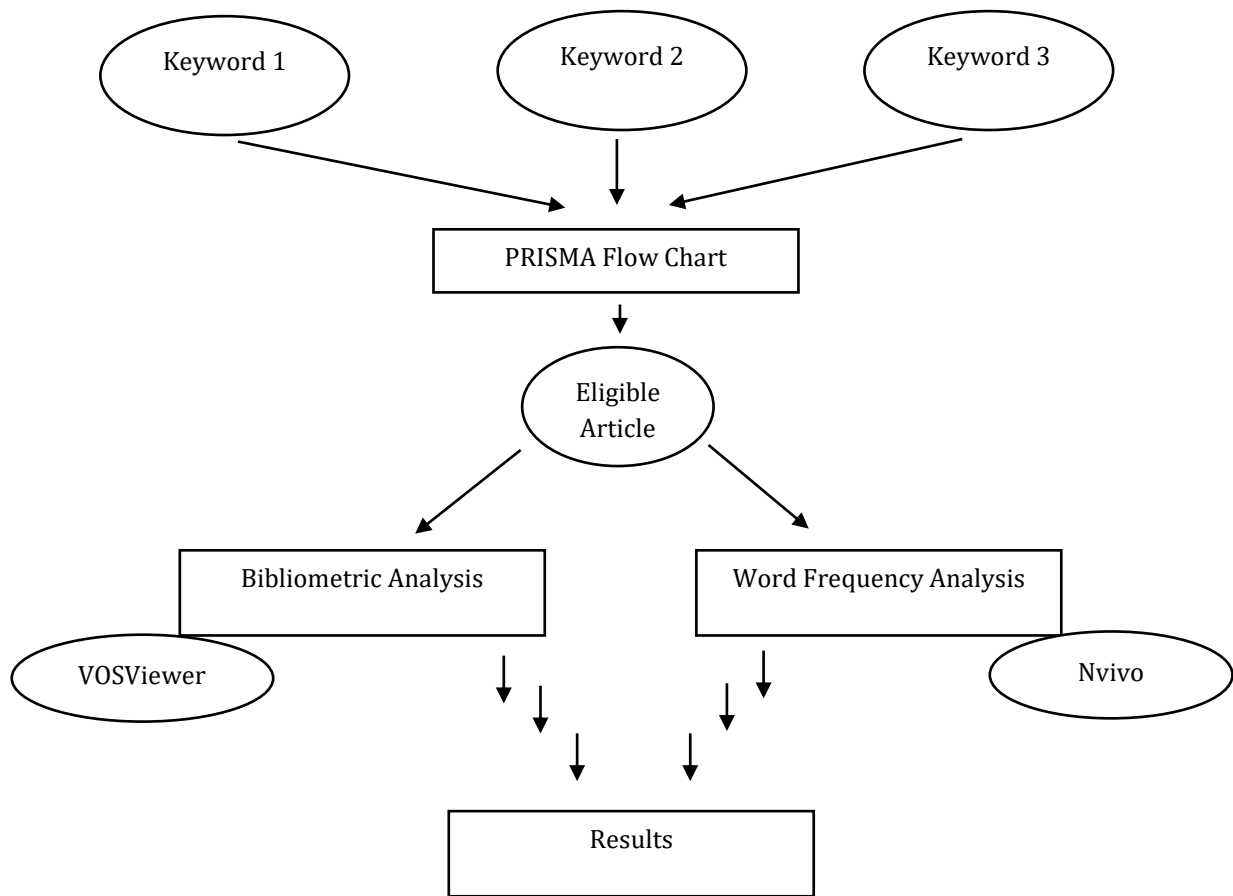

Figure 5. Research Design

A bibliometric analysis is employed to analyze the collected data on the selected subject (Nobanee et al., 2021). The bibliometric analysis utilized the technique of similarities visualization. Such visualization is called bibliometric mapping, and it allows observing connections in the scientific field structure in terms of authors, countries, documents, keywords, and other scientific production elements (Briones-Bitar et al. 2020; Nobanee et al. 2021). The bibliometric analysis is conducted in three stages: data compilation; software and data cleaning; and analysis, interpretation, and visualization (Nobanee et al., 2021). Moreover, Nvivo will be used to run a query for each article. This query is generated automatically and will result in how much the frequency for each word coded (QRIS International, 2022). The results of this analysis will be triangulated to generate interpretations. Creswell (2009) said the validity and reliability of qualitative research can be reached through triangulation. Sutopo (2006) said that there are kinds of triangulations technique, one of them is triangulation of methods. So this study will use that methods to generate a justification

RESULT & DISCUSSION

Before showing the results, the Systematic Literature Review method which has been carried out through a search process using Publish and Perish in the period 2010 to 2020, as shown in Figure 1, there are 253 publications for the first level screening process. Then, there are 119 articles will be removed because it is another form of an article (book review, chapter in a book, proceeding, and so on). At the second level, 40 articles are

excluded because the articles aren't published in Scopus and Web of Science (WOS) simultaneously, so 94 articles are left. At the further level, the articles that don't contain any keywords (32 articles) and are not related to the topic (5 articles) will also be excluded. At the final stage, there are 57 eligible articles will be included and processed for further analysis. Here is the figure that shows the PRISMA flowchart:

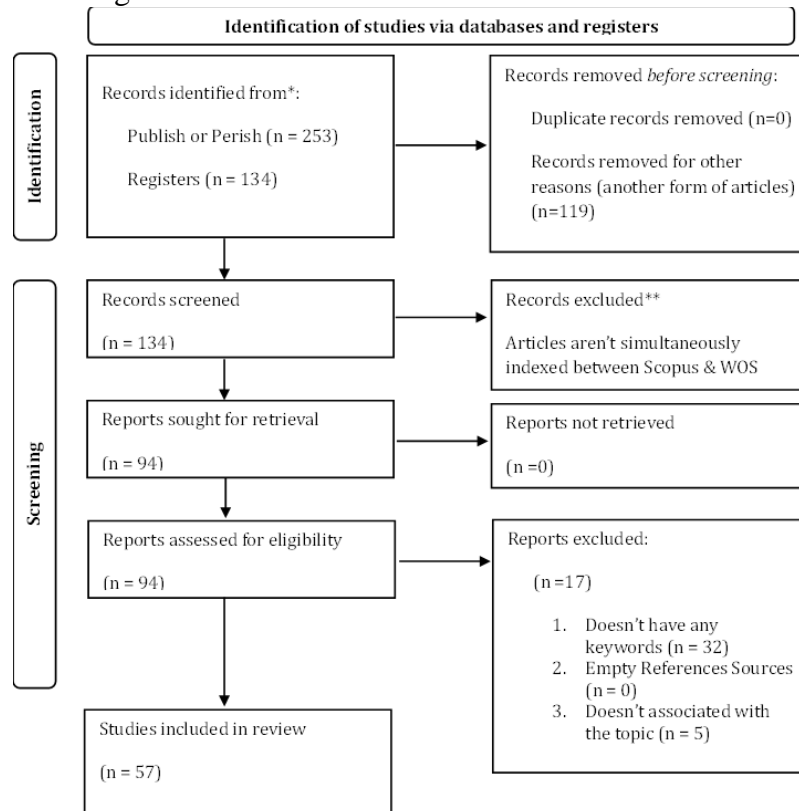

Figure 3. PRISMA Flowchart

As mentioned before, the eligible articles would be processed in the two types of analysis separately. Mapping or clustering the keywords (bibliometric analysis) for each eligible article would be carried out by Vos Viewer. Here is the figure that shows the result:

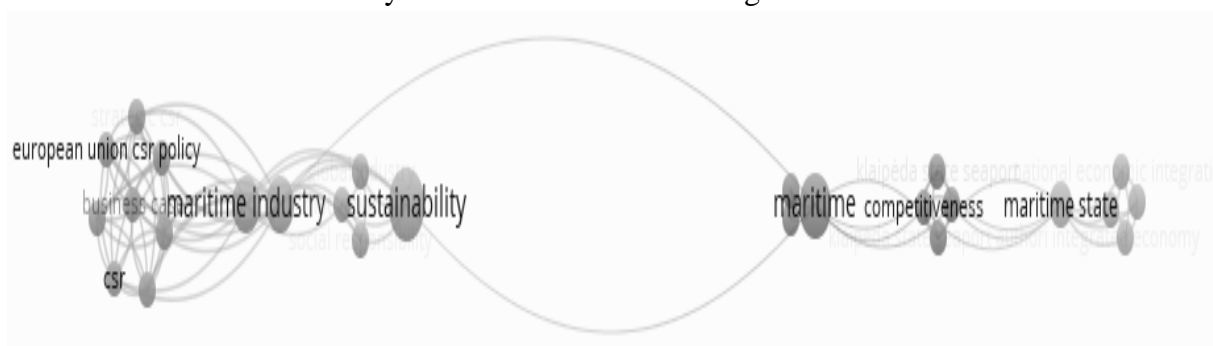

Figure 4. Keyword Cluster

In general, there are 4 types of clusters: (i). The 1st Cluster (Red) contains 8 nodes or items; (ii). The 2nd Cluster (Green) contains 7 nodes or items; (iii). The 3rd Cluster (Blue) contains

6 nodes or items; and (iv). The 4th Cluster (**Yellow**) contains 5 nodes or items. The following table shows the items for each cluster specifically:

Table 1. Cluster Nodes or Items

No.	Cluster	n	Nodes/Items
1	Red	8	Business Case
			Competitive Advantage
			Corporate Social Responsibility
			CSR
			Ethical Profit Maximisation
			EU CSR Programme
			Post-2008 Crisis
			Strategic CSR
2	Green	7	Competitiveness
			Emission Control Area
			Klaipeda State Seaport Authority
			Klaipeda State Seaport
			Maritime
			Mediterranean
			Transit
3	Blue	6	Global Industry
			Maritime Industry
			Motivation
			Shipping
			Social Responsibility
			Sustainability
4	Yellow	5	Archipelagic State
			Integrated Economy
			Marine Policy
			Maritime State
			National Economic Integration

Source: Vos Viewer

The node of “**Maritime**” is linked to the other nodes, such as: Sustainability, Shipping, Klaipeda Seaport Authority, Klaipeda Seaport, and Competitiveness. To see more specifically, the following figure (Figure 5) would show that means:



Figure 5. Maritime vs Sustainability vs Shipping vs Competitiveness

According to the result above, it can be concluded that maritime aspects are also linked to the shipping, sustainability, and competitiveness aspect. Moreover, the other nodes in another cluster relatively show a further finding. The following figure would show the findings:



Figure 6. Marine Policy vs Competitiveness

According to the result above, it can be concluded that “Marine Policy” nodes are indirectly related to the “Competitiveness” nodes. It can be concluded that, the study of maritime policy is usually related to the competitiveness aspects. Furthermore, the “Marine Policy” is directly related to the “Integrated Economy”, “National Economic Integration”, and “Archipelagic State. It means that marine policy is very relevant for an archipelagic country that focused on connectivity aspects. It can be implied that if connectivity exists, the integration of the economy can generate more competitiveness. Moreover, other results are found in that analysis, here is the Figure 7 that shows what it means:



Figure 7. Sustainability vs EU CSR Policy

According to the result above, it can be seen that “Sustainability” nodes are indirectly linked to the CSR aspects, such as: “EU CSR Policy” and “Strategic CSR” nodes. The results can imply that the sustainability of the maritime industry can be linked to the CSR aspect. Moreover, sustainability can generate more competitiveness (Sustainability vs Competitive Advantage). Furthermore, the separate analysis is also run in an Automatic Query through Nvivo. Figure 8 shows the result:



Figure 8. Word Frequency Analysis

This figure gives a comprehensive view and further findings. There are many words are displayed. However, the words Competitiveness, Responsibilities, Environmentally, Infrastructure, Entrepreneurial, Characteristics, and so on are the most frequent words in all eligible articles. Moreover, the Query result is chosen in the Synonym option to see what the meaning of the words is typical. The further result can be seen in Table 2 in which Competitiveness (85 times), Characteristics (62 times), and environmentally are the most frequent words generated in 57 eligible articles. Furthermore, there are other findings in the query such as: Infrastructure and Interconnections that have 22 and 19 frequencies respectively.

Table 2. Automatic Synonym Query Result

No.	Word	Length	Count	Weighted Percentage (%)	Similar Words
1	competitiveness	15	85	0,02	competitiveness
2	characteristics	15	62	0,02	characteristics
3	environmentally	15	61	0,02	environmentally
4	responsibilities	16	61	0,02	responsibilities, responsibilities', responsibilities'', responsibility'
5	representatives	15	46	0,01	constitutionally, correspondently, correspondingly, interpretations, representatives
6	recommendations	15	40	0,01	recommendations
7	entrepreneurship	16	34	0,01	entrepreneurship, entrepreneurship
8	internationally	15	26	0,01	internalization, internalization, internationalism, internationally, nationalities#provisions
9	acknowledgments	16	23	0,01	acknowledgment, acknowledgments, acknowledgments
10	conceptualization	17	23	0,01	conceptualization, conceptualizations, conceptualizing, conceptualization, conceptualizing
11	Maritime affairs	15	23	0,01	Maritime affairs
12	infrastructures	15	22	0,01	infrastructural, infrastructures
13	interconnection	15	19	0,01	interconnectedness, interconnecting, interconnection, interconnections, interconnectivity



14	administrations	15	15	0,00	administrations, administratively, organisationally
15	differentiation	15	14	0,00	differentiating, differentiation, specializations
16	entrepreneurial	15	14	0,00	entrepreneurial
17	straightforward	15	14	0,00	straightforward
18	interoperability	16	13	0,00	interoperability
19	interpretations	15	13	0,00	interpretations, understandable'
20	comprehensively	15	12	0,00	comprehensively, comprehensiveness, understandable'

Source: Nvivo

Based on the analysis generated before, it means that the analysis relatively generates the same results where the competitiveness and sustainability issues are commonly related to the maritime study. Moreover, connectivity and infrastructures aspect is also commonly linked to maritime issues. So that from these results, it can be concluded that, infrastructure support by the government can generate more connectivity in the maritime sectors. Moreover, connectivity can also generate more competitiveness for the country. For example, the study generated by Ly (2021) identified the connection between Foreign Direct Investment (FDI) and the Belt and Road Initiative (BRI) project. This study concludes that the project generates more capital inflow in Cambodia. So, it can be concluded that the connectivity (The BRI Project) generates more competitiveness. Moreover, the connectivity can support the special area (*Kawasan Ekonomi Khusus/KEK*) to still grow. The growth of KEK can generate more capital inflow the areas. Baranski et al. (2012) argue that KEK in Indonesia generates a positive sentiment for investor to invest more.

CONCLUSION

According to the analysis, the main conclusion is that the maritime sector can generate more competitiveness through connectivity. Higher competitiveness can generate more FDI for the countries. Moreover, according to the analysis, connectivity can be achieved through infrastructures. Not only the competitiveness aspect, the maritime issues can be also linked to environmental issues (sustainable development). This study implies that if the government can provide more higher infrastructure, it can generate more competitiveness and sustainability, especially for archipelagic countries (especially Indonesia) through connectivity. The increasing competitiveness can attract more capital inflow (FDI) and affect the long-run economic growth. Moreover, this research recommends for the government: (i). Provide more infrastructures to achieve more connectivity, especially for the isolated area; (ii). Using more advanced technology to provide better connectivity and coordination between stakeholders; and (iii). Involving the researcher, academist, or university both nationally and internationally to enhance the quality of Human Resources in the maritime sector.

REFERENCES

- Akiner, I., & Akiner, M. E. (2009). Evaluation of Turkish Construction Industry through the Challenges and Globalization. *Organization, Technology, and Management in Construction International Journal* 1(2). **Organization, Technology, and Management in Construction International Journal** 1(2), 64-71.
- Altar-Tur, A., Gomez Fuster, J. M., Navarro Azorin, J. M., & Ramos-Parreno, J. M. (2016). Estimating the Economic Impact of a Port through Regional Input-Output Tables: Case Study of the Port of Cartagena (Spain). *Maritime Economics & Logistics* 18(4), 371-390.
- Anderson, J. E. (1997). **Public Policy Making: An Introduction - Third Edition**. Boston: Houghton Mifflin Company.
- Banerjee, A., Duflo, E., & Qian, N. (2020). On the road: Access to transportation infrastructure and economic growth in China. *Journal of Development Economics*, 145, 102442.
- Baranski, Pawel., Zagun, Kiejstut., (2012). “**Special Economic Zone.**” KPMG in Poland
- Brones-Bitar, J. P., Carrión-Mero, Montalván-Burbano, N., & Morante-Carballo, F.,& Rockfall (2020). Research: A bibliometric analysis and future trends, *Geosciences*, 10, no. 10, pp 403.
- Chan, E. H., & Tse, R. Y. (2003). Cultural Considerations in International Construction Contracts. *Journal of Construction Engineering and Management*, 129(4), 375-381.
- Chen, Y., Fan, Z., Zhang, J., & Mo, M. (2019). Does the connectivity of the Belt and Road Initiative contribute to the economic growth of the Belt and Road countries?. *Emerging Markets Finance and Trade*, 55(14), 3227-3240.
- Creswell, J. W. (2009). **Research Design - Qualitative, Quantitative, & Mixed Methods Approaches: Third Edition**. SAGE Publication
- Dikbas, A., & Akkoyun, I. (2006). ETP: European Technology Platforms - A challenge for Turkey's Strategic Innovation Agenda. *ITU A|Z*, 3, 53-70.
- Dubois, A., & Gadde, L. E. (2002). The Construction Industry as a Loosely Coupled System: Implications for Productivity and Innovation. *Construction Management and Economics*, 20(7), 621-631.
- Dye, T. R. (2013). **Understanding Public Policy, 15th Edition**. New York: Pearson New International Edition.
- Hillebrandt, P. M. (2000). **Economic Theory and The Construction Industry. 3rd ed.** Wiltshire: MacMillan Press Ltd.
- Ly, B. (2021). The implication of FDI in the construction industry in Cambodia under BRI. *Cogent Business & Management*, 8(1), 1875542.
- Martono, R. V. (2019). **Logistic Management**. PT. Gramedia Pustaka Utama, Jakarta
- Ng, C. P., Law, T. H., Jakarni, F. M., & Kulanthayan, S. (2019, April). Road infrastructure development and economic growth. In *IOP Conference Series: Materials Science and Engineering* (Vol. 512, No. 1, p. 012045). IOP Publishing.
- Nobanee, H., Alqubaisi, G. B., Alhameli, A., Alqubaisi, H., Alhammadi, N., Almasahli, S. A., & Wazir, N. (2021). Green and Sustainable Life Insurance: A Bibliometric Review, *Journal of Risk and Financial Management* 14, no. 11 pp. 563.
- Peter, S. Rita, E., & Edith, M. (2015). The impact of road transportation infrastructure on economic growth in Nigeria. *International Journal of management and commerce innovations*, 3(1), 673-680.
- Pradhan, R. P., & Bagchi, T. P. (2013). Effect of transportation infrastructure on economic growth in India: The VECM approach. *Research in Transportation economics*, 38(1), 139-148.
- QRS International, NVIVO User Help (2022), from NVIVO: https://help-nv11.qrsinternational.com/desktop/procedures/run_a_word_frequency_query.htm
- Rushton, A., Croucher, P., & Baker, P. (2010). **The Handbook of Logistics and Distribution Management - Fourth Edition**. Great Britain: Kogan Page Limited.
- Şeker, A. (2020). The impacts of liner shipping connectivity and economic growth on international trade case of European Countries and Turkey. In *Handbook of research on the applications of international transportation and logistics for world trade* (pp. 139-150). IGI Global.
- Sutopo, H. B. (2006). **Qualitative Research Method**. Universitas Sebelas Maret.
- Wang, C., Lim, M. K., Zhang, X., Zhao, L., & Lee, P. T. W. (2020). Railway and road infrastructure in the Belt and Road Initiative countries: Estimating the impact of transport infrastructure on economic growth. *Transportation Research Part A: Policy and Practice*, 134, 288-307.
- Yu, H. (2017). Infrastructure connectivity and regional economic integration in East Asia: Progress and challenges. *Journal of Infrastructure, Policy and Development*, 1(1), 44-63.

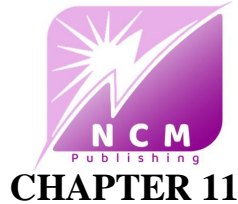

Diversity on Productivity: Anything for Efficiency & Effectiveness?

Samuel PD ANANTADJAYA

Sekolah Tinggi Manajemen IPMI, Indonesia

samuel.anantadjaya@ipmi.ac.id

Orcid: 0000-0002-9256-9186

Irma M NAWANGWULAN

International University Liaison Indonesia, Tangerang

irma.nawangwulan@iuli.ac.id

Orcid: 0009-0006-4164-3311

ABSTRACT

Organizational goals are mainly concerned about the level of efficiency and effectiveness. This is not surprising as the higher levels on efficiency and effectiveness lead to bulkier bottom-line. With the hefty income, organizations can have more retained earnings and dividends. Higher retained earnings means that future development becomes feasible. This pushes up the organizational market values. Dividends satisfy shareholders. Employees are loyal. If this is so, organizations should all have continued to exist in the market. However, the market shows also that organizations failed. This study attempts to seek possible causes on failure to reach the higher levels on efficiency and effectiveness through the lens on diversity management and employee loyalty. As Indonesia is an archipelago country that consists of people of multiple differences, it becomes important to evaluate the likelihood impact of diversity toward employee loyalty to reveal the influential impacts to organizations. The incorporated variables in this study includes; employee diversity, employee loyalty, quality of human resources, and productivity to represent the level of managerial efficiency and effectiveness. Relying on the previous network and acquaintances, this study includes respondents of Indonesian expatriates in other countries. The results are expected to show positive relationships among variables. The results provide the foundation for educational institutions and educators to start relaying the message on the importance of diversity.

Keywords: Diversity; Managerial Efficiency, Managerial Effectiveness; Employee Loyalty; Quality of Human Resources; Employee Productivity

INTRODUCTION

Employee diversity and demography have been regarded as important elements toward shaping the organizational culture (Gorton & Zentefis, 2020; Ramakrishnan & Testani, 2011) & commitment (Alkadash, 2020; Aziz, et al., 2021; Cohen, 2013; Nikpour, 2017; Anantadjaya, Finardi, & Nawangwulan, 2010; Abdurohim, Anantadjaya, Jayanto, Kusdiby, & Cakranegara, 2022). Both the primary and secondary characteristics of people are likely providing degrees of influence in terms of attaining productivity (Affum-Osei, Acquah, & Acheampong, 2015; Rabindarang, Khuan, & Khoo, 2014; Tandon, Mishra, & Mehta, 2020). Syed (2010) had studied the relationship between demography and commitment, which consisted of some factors of the primary and secondary characteristics of people (Khan, Khan, Khan, Nawaz, & Yar, 2013). This is confirmed by Jones & George (2008) by noting the variations of people are likely based on education, experience, physical appearance, age, gender, race, ethnicity, religion, sexual orientation, socio-economy, ability, and others. This pushes-forth for enhancement in human resources practices inside organizations worldwide in recruiting and retaining diverse employees (Ferrel, Hirt, & Ferrel, 2016). According to Saikh (2019), some notable benefits of diversity inside organizations include; multiple perspectives, improved engagements, attract talents, enhance global image, higher revenues, and easier troubleshooting (Anantadjaya, Nawangwulan, Kusumah, Setio, & Kartika, 2015; Setio & Anantadjaya, 2014).

An age-related relationship had been previously investigated in Ghana, India and Nigeria, for instance, to have connections to commitment (Affum-Osei, Acquah, & Acheampong, 2015; Bashir & Abdul, 2020; Amangala, 2013). Likewise, gender & commitment relationships had also been previously studied (Rabindarang, Khuan, & Khoo, 2014; Affum-Osei, Acquah, & Acheampong, 2015). Along with gender-based research, gender roles (Elkhdr & Kanbur, 2018), socio & cultural differences (Rabindarang, Khuan, & Khoo, 2014) are influential for masculinity and femininity (Khan, Khan, Khan, Nawaz, & Yar, 2013). Though females tend to be less-committed in a masculine-based organizations, however, studies have found out that female educators show a higher degree of commitment (Bashir & Abdul, 2020). Also, there were evidence on productivity improvement due to the mix of female and male workers in organizations (Khan, Khan, Khan, Nawaz, & Yar, 2013). In an international setting, ethnicity may push-up the level of satisfaction and motivation toward jobs when there are colleagues from the same ethnicity. Ethnicity may also provide joyful experience in inter-cultural interactions (Fujishiro, Heaney, & Hoppe, 2013). In the studies by Jones, Ni & Wilson (2009) found out that minorities tend to have a higher perception on discrimination at work. This results in employee disengagement and intention to stay. Management fairness must be ensured to all employees in accordance with the positions, ability, or competence. Individual's marital status generally correspond to the level of motivation toward work and job satisfaction (Knerr, 2002). Unmarried individuals have the tendency to show relatively minimal levels for work motivation and job satisfaction. This is translated into a lesser level of organizational loyalty, nonetheless (UKEssays, 2017). Blood type has also been studied to show influence onto individual's personality (Sakamoto & Yamazaki, 2002; Cattell,



Young, & Hundleby, 1964). As the personality contributes to the individual's behaviors, it certainly affects the level of quality of human resources toward loyalty and productivity.

Studies on years of work experience, or work background (Harvey, 2004), for instance, enable people to rely on multiple perspectives on organizational planning, strategies, alternatives and out-of-the-box solutions (Alexandra, 2017; Mohebbifar, Khosravizadeh, Mohseni, Bakhtiari, & Cheginy, 2014). Previous studies on employees' work experience found out that the longer years of work experience, the higher the levels of work motivation and job satisfaction (Mohebbifar, Khosravizadeh, Mohseni, Bakhtiari, & Cheginy, 2014). Education shows the approximation on accumulated knowledge, contributes in shaping the behaviors of the individuals (Nakosteen, 2021). As higher education contributes to higher employment opportunities, better compensation, and better bargaining power, it is often regarded as a crucial contributor in shaping the level of quality of human resources, employment loyalty, employment diversity, and productivity (Organization for Economic Co-operation and Development, 2019). As the basic element in demography, individual's age drives personality, taste and preferences (Mialki, 2021; Tandon, Mishra, & Mehta, 2020), just like the certain characteristics of generations of baby boomers, millennials, generation X, generation Z, or others. One's age approximates the quality, engagement, and productivity (Sousa, Ramos, & Carvalho, 2019).

From the perspective of employee loyalty, Susan DeFranzo (2021) stated that it is defined as people who are devoted to the organization's success. They believe that being a part of the organization is in their best interests, have plans to remain within the organization for the long-term, and do not actively seek other employment opportunities elsewhere (DeFranzo, 2021). Money is not the sole reason for an employee to work in an organization, as other factors of non-financial compensation such as providing safe and appropriate working facilities can help increase job satisfaction and loyalty (Sutanto & Perdana, 2016). Saydam Gouzali (2004) claims that it is impossible to use the exact same motivation-raising methods for every employee, due to the different factors and the differences in attitudes towards motivators that push an employee to work. Managers need to study these factors more closely to turn these motivators into "weapons" that will act as a stimulus to promote diligence, the presence of high levels of potential and loyalty to the organization. There are 4 indicators of employee loyalty; obedience (Sutanto & Perdana, 2016), responsibility (Yazaki, 2010; Maineldi, Hendriani, & Daulay, 2014), dedication (Sutanto & Perdana, 2016; Gaither, 2016), and integrity (Gouzali, 2004; Sutanto & Perdana, 2016; Indeed, 2021)

2. METHODOLOGY

This study relied on the previous network and acquaintances. Via online questionnaire distribution in social media and direct emails, a total of 200 Indonesian expatriates in countries around the world are included in this study. Relying on the Raosoft Sample Size Calculator, which is available online, the use of 200 total samples have satisfied the statistical inferences to have 10% error but yet still maintain 99% confidence level though with 50% to ensure the largest possible sample size as this study do not presume skewness

in the data. Starting with this assurance, the sampling method was incorporated based on at least 2 ways in obtaining responses. Initially, the purposive sampling was used to start establishing contacts with the Indonesian expatriates. The snow-balling sampling was also used to get the contact rolling from one expatriate to another. This study strives for distribution of the Indonesian expatriates across nations worldwide. The respondents were extended their consent and their names were maintained anonymous while their respective responses were acknowledged for further data analysis

Figure 1: Raosoft Sample Size Calculator

The screenshot shows the Raosoft Sample Size Calculator interface. It features a blue header with the Raosoft logo. Below the header, there are four input fields with corresponding labels and instructions:

- What margin of error can you accept?** (5% is a common choice): 10%
- What confidence level do you need?** (Typical choices are 90%, 95%, or 99%): 99%
- What is the population size?** (If you don't know, use 20000): 20000
- What is the response distribution?** (Leave this as 50%): 50%

At the bottom, it displays the result: **Your recommended sample size is 165**.

While the targeted respondents were 200 to proportionately represented the continents in the world, there were 52 incomplete responses. The spread of the samples is shown in the following table,

Table 2: Sampling Process

	Details	Notes	#s of Respondents
Population	Indonesian expatriates worldwide		
Sampling – Cluster	Continents or Regions	North, Central & South America	50
		Eastern & Western Europe, including the Scandinavian countries	50
	All respondents were maintained anonymously throughout this study	Australia	50
		Asia & the Middle East	50
Total Samples			200

The questionnaire consists of employee diversity (age, gender, ethnicity, blood type, marital status, experience, education, residence), quality of human resources (knowledge, skills, attitude), employee loyalty (obedience, responsibility, dedication, integrity) and productivity (efficiency, effectiveness). This study attempts to focus on the vital role of diversity in employee loyalty to bring about the satisfactory level of productivity. Once this process is properly managed, it is expected that the cycle will re-invent itself toward sustainability

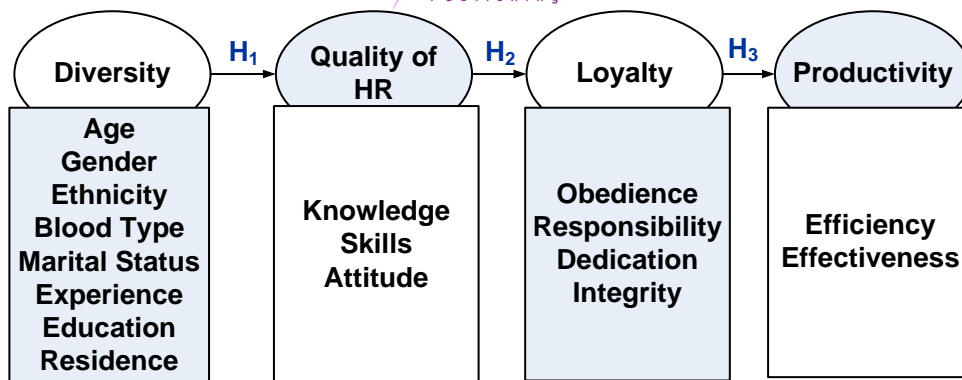

Referring to the above discussions and the variables used in this study, the hypotheses are as follows;

H₁ : There is a positive & significant relationship between Diversity and Quality of HR

H₂ : There is a positive & significant relationship between Quality of HR and Employee Loyalty

H₃ : There is a positive & significant relationship between Employee Loyalty and Employee Productivity

3. DATA ANALYSIS

The available data from the respondents were run into the SPSS. The results are statistically acceptable for validity (.77) & reliability (.80), then it was analyzed in AMOS to simultaneously evaluate the relationships among variables. The level of fitness of the model appeared to be satisfactory. It is interesting to note that the presence of diversity provides some degree of influence toward the quality of HR inside companies. The sequence continues with the presence of quality of HR positively influences the presence of employee loyalty, which brings about the positive relationship unto the employee productivity.

Table 3: Goodness of Fit Model Results

Measurement Criteria	Schumacker & Lomax (2010); Wijaya (2009)	Ghozali (2004); Santoso (2009)	Cucos (2022)	Result	Fit
CMIN/df (Normed Chi-Square)	CMIN/df ≤ 2 = better	CMIN/df ≤ 5 = better	≤ 3 = acceptable fit ≤ 5 = reasonable fit	1.473	Good
RMSEA (Root Mean Square Error of Approximation)	RMSEA ≤ 0.08 = better	RMSEA ≤ 5 = better	≤ 0.05 = reasonable fit	0.115	Good
GFI (Goodness of Fit Index)	GFI value closer to 1 = better	GFI value closer to 1 = better	1 = perfect fit ≥ 0.95 = excellent fit ≥ 0.9 = acceptable fit	0.817	Good

Measurement Criteria	Schumacker & Lomax (2010); Wijaya (2009)	Ghozali (2004); Santoso (2009)	Cucos (2022)	Result	Fit
AGFI (Adjusted Goodness of Fit Index)	AGFI value closer to 1 = better	AGFI \geq 0.09 = better	\geq 0.90 = acceptable fit	0.772	Good
TLI (Tucker-Lewis's Index)	TLI value closer to 1 = better	TLI \geq 0.09 is better	TLI value closer to 1 = perfect fit TLI value closer to 1 = very good fit	0.726	Good
NFI (Normed Fit Index)	-	NFI \geq 0.09 is better	1 = perfect fit	0.701	Good
CFI (Comparative Fit Index)	CFI closer to 1 = better	CFI closer to 1 = better	1 = perfect fit \geq 0.95 = excellent fit \geq 0.90 = acceptable fit	0.726	Good
PNFI (Parsimonious Goodness of Fit Index)	-	Higher PNFI value = better	-	0.546	Good
PGFI (Parsimonious Goodness of Fit Index)	-	-	-	0.60	Good
RMR (Root Mean Residual)	RMR \leq 0.05 = better	RMR \leq 0.05 = better	\leq 0.05 = acceptable fit \leq 0.07 = acceptable fit	0.055	Good

Source: (Budiman, Anantadjaya, & Prasetyawati, 2014)

With all positive influence among variables, it is interesting to note such relationships provide evidence to what people have actually expected inside organizations. The presence of diversity, first of all, as the variable in this model, is certainly explained by numerous sub-variables, such as; age (.82), gender (.13), ethnicity (-.10), blood type (.44), marital status (.36), experience (.92), education (.67), and residence (.17). The only negative explanatory power can be observed from ethnicity.

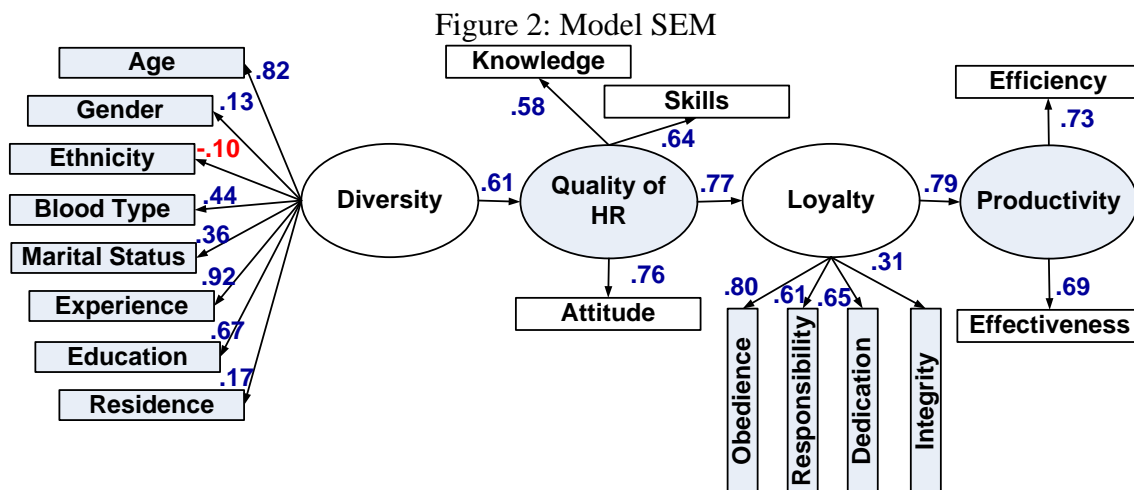

Nonetheless, since this study emphasizes on Indonesian expatriates around the world, the differences within Indonesian ethnic groups, of more than 1,300 ethnic groups (Rahmat, 2021; Badan Pusat Statistik, 2021) become inapparent for the world to notice. Also, the chances of meeting people from the same ethnic group are relatively slim worldwide. Inside firms, management shall pay a closer attention into these elements as way to properly gauge the presence of organizational diversity.

The presence of quality of HR is portrayed from the classic combination of knowledge (.58), skills (.64), and attitude (.76) in this study. As the attitude shows the highest explanatory power unto the presence of quality of HR, this result confirms the vital role of attitude in employees' mindset, not only better than knowledge and skills, but also better than IQ, aptitude, talent, intelligence, education, money, wealth, past history, connections, and networking (Vaughn-Furlow, 2017).

From the perspective of employee loyalty, the results show obedience (.80), dedication (.65), responsibility (.61) and integrity (.31), respectively. These results mirror the common practice as employees' loyalty often times is tied into the level of employees' obedience rather than the other elements. Though there are possibilities in falling into the trap of blind obedience (Pejvack, 2020; Hess, 2013), it appears that basic conformity still measures the level of loyalty & the worldwide organizations where the Indonesian expatriates are employed seem to maintain the perception that obedience is the key success factor in controlling employee loyalty.

The results on productivity reveals that efficiency is able to provide the explanatory power of 73% while effectiveness is a mere 69%. These results provide evidence that both efficiency and effectiveness are able to support the existence of employee productivity. With the fact that the impact to employee productivity is 79%, these outcomes appear to support this research model that there are relationships between employee diversity, quality of HR, loyalty and employee productivity

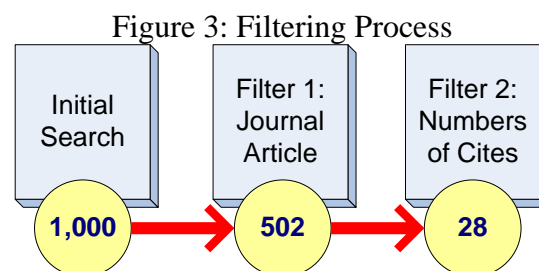

To provide qualitative confirmations, this study run also the systematical literature review on some keywords used in the model, which are; employee diversity, quality of HR, employee loyalty & employee productivity. Based on those keywords, the search into the CrossRef database was incorporated to reach 1,000 literatures. The filtering steps are based on journal articles and the number of cites of a minimum of 50.

It is a bit surprising to know that based on the number of citations There are only 28 articles selected based on the filtering steps and those selected articles were published in Wiley (9), Emerald (6), Informa UK Limited (5), Springer (4), Elsevier (3) & the

American Psychological Association (1).

Figure 4: Selected Publishers

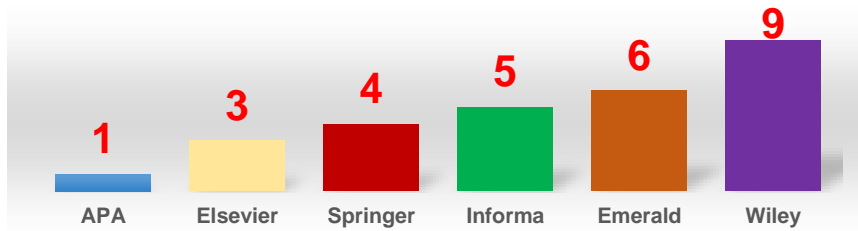

The total numbers of citations can be seen from the **Figure 5: Number of Citations** that there are 8 articles with the citations between 50-74 times, there are 4 articles with the total citations between 75-99 times, there are 5 articles with the total citations between 100-124 times, there are 2 articles with the total citations between 125-149 times, there are 3 articles with the total citations between 150-174 times, there are 2 articles with the total citations between 175-199 times, and there 4 articles with the total citations of more than 200 derivative publications.

Figure 5: Number of Citations

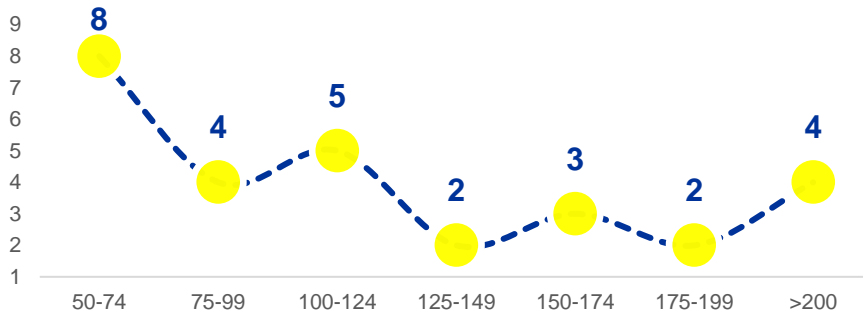

The following pie chart shows the total accumulated citations over the years; before the year of 2000, there were 550 citations, between the year of 2000-2009, there were 911 citations, and between 2010-2019, there were 2,419 citations.

Figure 6: Accumulated Citations

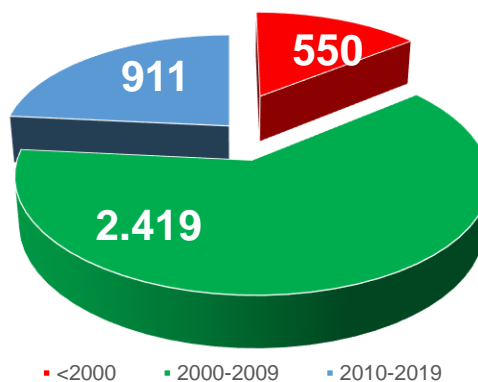

This shows that the selected keywords have become popular and organizations appear to



have experienced complexities around managing employee diversity, enhancing quality of HR, staggering slides in employee loyalty and diminishing employee productivity. The emphasis toward employee-related matters have been perceived as increasingly valuable for organizational sustainability instead of just a mere expendable without significant roles & contribution.

CONCLUSION

Based on the analysis in this study, it can be safely concluded that the role of employee diversity holds a vital role in pushing-forward the quality of HR, employee loyalty and productivity. The sets of literature appear to be providing support toward the relationships among the variables and sub-variables. The positive relationships and impact are confirmed. Also, the additional mini analysis on the systematic literature review seems to suggest the rising interest in these subjects.

Future studies may have to explore more potential respondents to even enrich the dynamics, or even putting more focus into particular variables, such as the negative explanatory power of ethnicity, or the minimal power of gender as to touch-on the gender issues encircling the topic on diversity

REFERENCES

- Abdurohman, D., Anantadjaya, S. P., Jayanto, I., Kusdibyo, & Cakranegara, P. A. (2022, September). Examining Factors That Can Improve Employee Performance. *Jurnal Manajemen Bisnis*, 9(2), 308-319. doi:<https://doi.org/10.33096/jmb.v9i2.309>
- Affum-Osei, E., Acquah, E., & Acheampong, P. (2015). Relationship between Organisational Commitment and Demographic Variables: Evidence from a Commercial Bank in Ghana. *American Journal of Industrial and Business Management*, 5, 769-778. doi:<http://dx.doi.org/10.4236/ajibm.2015.512074>
- Alexandra, K. (2017, June 14). *Why Your Skill Diversity Is Your Career Strength*. Retrieved May 14, 2021, from Work180: <https://au.work180.co/blog/why-your-skill-diversity-is-your-career-strength>
- Alkadash, T. M. (2020, March-April). Mediating Role Between Authentic Leadership, Organizational Commitment on Talents Turnover Intention: in Palestine Higher Education. *TEST Engineering & Management*, 83, 5320-5341. Retrieved August 3, 2021, from <https://ssrn.com/abstract=3751065>
- Amangala, T. A. (2013). The Effect of Demographic Characteristics on Organisational Commitment: a Study of Salespersons in the Soft Drink Industry in Nigeria. *European Journal of Business and Management*, 5(18), 109-118. Retrieved February 12, 2022, from <https://www.iiste.org/Journals/index.php/EJBM/article/viewFile/6649/6793>
- Anantadjaya, S. P., Finardi, B. A., & Nawangwulan, I. M. (2010). Family Members & Family Business Activities: A Psychological Contract? *The 2nd Indonesia International Conference "Innovation, Entrepreneurship & Small Business"*. Bandung: Institut Teknologi Bandung & Universitas Multimedia Nusantara. July 31, 2021 tarihinde https://papers.ssrn.com/sol3/papers.cfm?abstract_id=1645707 adresinden alındı
- Anantadjaya, S. P., Nawangwulan, I. M., Kusumah, A. I., Setio, Y., & Kartika, C. (2015, April-June). Does the Image of Indonesian Contemporary Artists Matter? A Theoretical Review on Personal Diversity, Brand Image, Market Acceptance & Market Opportunity. *Independent Journal of Management & Productivity*, 6(2), 378-422. doi:10.14807/ijmp.v6i2.280

Accounting Inquiries with New Approaches in the Post-Pandemic Era
Volume I

- Aziz, H. M., Othman, B. J., Gardi, B., Ahmed, S. A., Sabir, B. Y., Ismael, N. B., . . . Anwar, G. (2021, May-June). Employee Commitment: The Relationship Between Employee Commitment and Job Satisfaction. *Journal of Humanities and Educational Development*, 54-66. doi:10.22161/jhed.3.3.6
- Badan Pusat Statistik. (2021). *Statistik Indonesia: Statistical Year Book of Indonesia 2021*. Jakarta, Indonesia: BPS-Statistics Indonesia. Retrieved November 16, 2022
- Bashir, B., & Abdul, G. (2020, February 5). Correlates of Organisational Commitment Among University Teachers in India: An Empirical Investigation. *Asian-Pacific Journal of Management Research and Innovation*, 16(1). doi:<https://doi.org/10.1177/2319510X19872632>
- Budiman, A., Anantadjaya, S., & Prasetyawati, D. (2014, March 11). Does Job Satisfaction Influence Organizational Citizenship Behavior? An Empirical Study In Selected 4-Star Hotels In Jakarta, Indonesia. *RIBER: Review of Integrated Business and Economics Research*, 3(1), 130-149. Retrieved March 4, 2022, from SSRN: https://papers.ssrn.com/sol3/papers.cfm?abstract_id=2406800
- Cattell, R. B., Young, H. B., & Hundleby, J. D. (1964). Blood Groups and Personality Traits. *American Journal of Human Genetics Vol. 16 No. 4*.
- Cohen, A. (2013). Organizational Commitment Theory. In E. H. Keesler, *Encyclopedia of Management Theory* (Vol. 2, pp. 526-529). Thousand Oaks, CA, USA: Sage Publication. doi:<http://dx.doi.org/10.13140/2.1.4327.4881>
- Cucos, L. (2022, January 18). *How To Interpret Model Fit Results In AMOS*. Retrieved March 11, 2022, from Uedufy: <https://uedufy.com/how-to-interpret-model-fit-results-in-amos/>
- DeFranzo, S. (2021). *Tips To Improve Employee Loyalty, Part 1*. Retrieved March 20, 2021, from Snap Surveys: <https://www.snapsurveys.com/blog/tips-improve-employee-loyalty>
- Elkhdr, H. R., & Kanbur, A. (2018, December). Organizational Commitment in Relation to Demographic Characteristics among Lecturers Working at Libyan Universities. *International Journal of Humanities and Social Science Invention (IJHSSI)*, 7(12), 46-52. Retrieved February 12, 2022, from [http://www.ijhssi.org/papers/vol7\(12\)/Ver-3/J0712034652.pdf](http://www.ijhssi.org/papers/vol7(12)/Ver-3/J0712034652.pdf)
- Ferrel, O., Hirt, G., & Ferrel, L. (2016). *Business: A Changing World - Tenth Edition*. New York: McGraw-Hill Education. Retrieved March 10, 2021
- Fujishiro, K., Heaney, C., & Hoppe, A. (2013, April 19). Workplace Racial/Ethnic Similarity, Job Satisfaction, And Lumbar Back Health Among Warehouse Workers: Asymmetric Reactions Across Racial/Ethnic Groups. Hoboken, New Jersey, United States. doi:<https://doi.org/10.1002/job.1860>
- Gaither, C. (2016, March 21). *9 Signs Of Employee Dedication Every Employer Should Be Aware Of*. Retrieved March 24, 2021, from LinkedIn: <https://www.linkedin.com/pulse/9-signs-employee-dedication-every-employer-should-gaither-md-faafp>
- Ghozali, I. (2004). *Model Persamaan Struktural: Konsep dan Aplikasi dengan program AMOS*. Semarang, Indonesia: Badan Penerbit Universitas Diponegoro. Retrieved March 5, 2022
- Gorton, G., & Zentefis, A. (2020, July 16). Corporate Culture as a Theory of the Firm: The Role of Values, Customs, and Norms. *Voxeu CEPR*, pp. Articles-Columns. Retrieved July 30, 2021, from <https://voxeu.org/article/corporate-culture-theory-firm-role-values-customs-and-norms>
- Gouzali, S. (2004). *Human Resources Management*. Jakarta: PT Toko Gunung Agung. Retrieved March 20, 2021
- Harvey, L. (2004). *Work Experience*. Retrieved May 14, 2021, from Analytical Quality Glossary: <http://www.qualityresearchinternational.com/glossary/workexperience.htm#>
- Hess, M. (2013, March 6). Think for Yourself: The Danger of Blind Obedience. p. Small Business. Retrieved November 16, 2022, from <https://www.cbsnews.com/news/think-for-yourself-the-danger-of-blind-obedience/>
- Indeed. (2021, February 8). *Integrity: Definition And Examples*. Retrieved March 24, 2021, from Indeed: <https://www.indeed.com/career-advice/career-development/integrity-at-work>
- Jones, G. R., & George, J. M. (2008). *Contemporary Management* (5th ed.). New York City, NY, USA: McGraw-Hill/Irwin.
- Jones, J., Ni, J., & Wilson, D. (2009). Comparative Effects Of Race/Ethnicity And Employee Engagement On Withdrawal Behavior. Pittsburgh, Pennsylvania, United States. Retrieved May 27, 2021, from <https://www.jstor.org/stable/40604643?seq=1>



- Khan, I., Khan, F., Khan, H., Nawaz, A., & Yar, N. B. (2013). Determining the Demographic impacts on the Organizational Commitment of Academicians in the HEIs of DCs like Pakistan. *European Journal of Sustainable Development*, 2(4), 117-130. Retrieved February 3, 2022, from <http://www.ecsdev.org/images/V2N2/khan%20117-130.pdf>
- Knerr, M. (2002). *An Empirical Analysis Of The Relationship Between Marital Status & Job Satisfaction*. Retrieved May 28, 2021, from URC: <https://www.kon.org/urc/v4/knerr.html>
- Maineldi, A., Hendriani, S., & Daulay, I. N. (2014, October). Pengaruh Kompensasi Dan Lingkungan Kerja Terhadap Loyalitas Karyawan Pada PT. Jatim Jaya Perkasa Kebun Banjar Balam Indragiri Hulu. Pekanbaru, Indonesia. Retrieved March 26, 2021, from <https://media.neliti.com/media/publications/33669-ID-pengaruh-kompensasi-dan-lingkungan-kerja-terhadap-loyalitas-karyawan-pada-pt-jat.pdf>
- Mialki, S. (2021, June 11). *What is Demographic Segmentation with 5 Examples*. Retrieved February 12, 2022, from Instapage: <https://instapage.com/blog/demographic-segmentation>
- Mohebbifar, R., Khosravizadeh, O., Mohseni, M., Bakhtiari, A., & Cheginy, Z. (2014, March). The Influence Of Employee's Work Experience On Priority Of Job Motivation Factors In Teaching Hospitals, Qazvin, Iran. Qazvin, Iran. Retrieved May 26, 2021, from https://www.researchgate.net/publication/281270045_The_Influence_of_Employee's_Work_Experience_on_Priority_of_Job_Motivation_Factors_in_Teaching_Hospitals_Qazvin_Iran
- Nakosteen, M. (2021, May 1). *Education*. Retrieved May 14, 2021, from Britannica: <https://www.britannica.com/topic/education>
- Nikpour, A. (2017). The Impact of Organizational Culture on Organizational Performance: The Mediating Role of Employee's Organizational Commitment. *International Journal of Organizational Leadership*, 6, 65-72. Retrieved August 2, 2021, from www.aimjournal.com
- Organization for Economic Co-operation and Development. (2019). *Education At A Glance*. Indonesia. doi:<https://doi.org/10.1787/19991487>
- Pejvack, N. (2020, January 24). Is There a Mystery to "Blind Obedience"? *Journey Magazine*. Retrieved November 16, 2022, from <https://journeymagazineptbo.com/2020/01/24/is-there-a-mystery-to-blind-obedience/>
- Rabindarang, S., Khuan, W. B., & Khoo, Y. Y. (2014). The Impact of Demographic Factors on Organizational Commitment in Technical and Vocational Education. *Malaysian Journal of Research - MJR*, 2(1), 56-61. Retrieved February 2, 2022, from https://www.researchgate.net/publication/283089130_The_Impact_of_Demographic_Factors_on_Organizational_Commitment_in_Technical_and_Vocational_Education
- Rahmat, H. (2021, July 8). Terbanyak di Dunia, Indonesia Miliki 1340 Suku Etnis. *Suara Pemerintah*, p. Indonesia Original. Retrieved November 16, 2022, from https://suarapemerintah.id/2021/07/terbanyak-di-dunia-indonesia-miliki-1340-suku-etnis/#google_vignette
- Ramakrishnan, S., & Testani, M. (2011). People, Process, Technology - The Three Elements for a Successful Organizational Transformation. *SEMS Webinar* (p. Mini Series of Transformational Change). Institute of Industrial & Systems Engineers. Retrieved July 30, 2021, from <https://www.iise.org/Details.aspx?id=24456>
- Sakamoto, A., & Yamazaki, K. (2002, April). *Blood-Typical Personality Stereotypes and Self-Fulfilling Prophecy: A Natural Experiment with Time-Series Data of 1978-1988*. Retrieved December 18, 2012, from Department of Psychology: www.hss.ocha.ac.jp/psych/socpsy/sakamoto/media/2003-2004/blood_typical.pdf
- Santoso. (2009). *SEM, Konsep dan Aplikasinya pada AMOS*. Jakarta, Jakarta, Indonesia: PT Elex. Retrieved March 5, 2022
- Schumacker, R. E., & Lomax, R. G. (2010). *A Beginner's Guide to Structural Equation Modeling (Third Edition)*. New York, New York, USA: Taylor and Francis Group, LLC.
- Setio, Y. B., & Anantadjaya, S. P. (2014, September). Peran Personal Diversity, Kompetensi & Kinerja Karyawan di Beberapa Perusahaan di Indonesia. *INSIGHT – EmergING Markets: BuSIness and*

Accounting Inquiries with New Approaches in the Post-Pandemic Era
Volume I

- ManaGement STudies Journal*, 179-201. Retrieved May 25, 2022, from <https://insight-journals.blogspot.com/>
- Shaikh, A. (2019, April 1). *Top 6 Benefits Of Diversity In The Workplace*. Retrieved May 11, 2021, from Grousum: <https://grousum.com/blog/tbenefits-diversity/>
- Sousa, I. C., Ramos, S., & Carvalho, H. (2019, September 27). Age-Diversity Practices and Retirement Preferences Among Older Workers: A Moderated Mediation Model of Work Engagement and Work Ability. (J. B. James, J. O. Mulders, & M. d. Molero, Eds.) *Frontiers in Psychology*. doi:<https://doi.org/10.3389/fpsyg.2019.01937>
- Sutanto, E. M., & Perdana, M. (2016, September). Antecedents Variable Of Employees Loyalty. Surabaya, Indonesia. Retrieved March 24, 2021, from http://repository.petra.ac.id/17599/1/Publikasi1_91022_3296.pdf
- Syed, A. (2010, July). Personality Hardiness, Job Involvement and Job Burnout among Teachers. *International Journal of Vocational and Technical Education*, 2(3), 36-40. Retrieved February 20, 2022, from https://www.researchgate.net/publication/228674649_Personality_hardiness_job_involvement_and_job_burnout_among_teachers
- Tandon, P., Mishra, S., & Mehta, J. D. (2020, September). A Study of Demographic Variables and Organizational Commitment of Employees. *International Journal of Management (IJM)*, 11(9), 1416-1424. doi:10.34218/IJM.11.9.2020.136
- UKEssays. (2017, May 11). *Relationship Between Marriage And Job Satisfaction*. May 17, 2021 tarihinde UKEssays: <https://www.ukessays.com/essays/psychology/relationship-between-marriage-and-job-satisfaction-psychology-essay.php#citethis> adresinden alındı
- Vaughn-Furlow, B. (2017, August 18). Attitude More Important Than Skills. *The Daily Leader*. Retrieved November 16, 2022, from <https://www.dailyleader.com/2017/08/18/attitude-more-important-than-skills/>
- Wijaya, T. (2009). Analisis Structural Equation Modeling Menggunakan AMOS. Yogyakarta, Indonesia: Universitas Atma Jaya. Retrieved March 5, 2022, from <http://202.162.35.204:8191/opac/DetailOpacBlank.aspx?id=4155>
- Yazaki. (2010). Responsibilities Toward Stakeholders. Tokyo, Japan. June 2, 2021 tarihinde https://www.yazaki-group.com/global/pdf/ser2010_09-18.pdf adresinden alındı

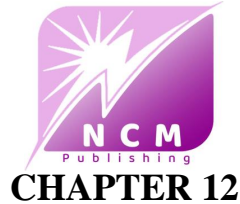

The Influence of Innovation Capabilities and Market Response Capabilities on Supply Chain Financing Adoption Moderated by Supply Chain Integration (In the Manufacturing Industry Joined in IPOMS)

Mrs. Tasya AMARTA

Ciputra University Surabaya
tamarta01@student.ciputra.ac.id
Orcid: 0009-0000-0005-3389

Timotius Febry CHRISTIAN

Ciputra University Surabaya
timotius.feby@ciputra.ac.id
Orcid: 0000-0002-5201-9673

ABSTRACT

The textile and garment industry has been one of the pillars supporting the growth of manufacturing in Indonesia. However, since the Covid-19 pandemic, the utility of the textile and garment subsector has been continuously declining. This research aims to explore how the innovation capabilities and market response capabilities of textile and garment manufacturing companies in Indonesia influence the adoption of supply chain financing through supply chain integration. A total of 135 managers from textile and garment manufacturing companies who are members of IPOMS (Indonesian Production & Operations Management Society) were taken as samples using the random sampling method. The data was then analyzed using SmartPLS 4.0. The results show that innovation capabilities and market response capabilities positively influence supply chain financing adoption, while supply chain integration does not moderate the relationship between innovation capabilities and market response capabilities on supply chain financing adoption. This research provides insights for managers of textile and garment manufacturing companies in Indonesia to improve performance and competitiveness.

Keywords: Innovation Capabilities, Market Response Capabilities, Supply Chain Integration, Supply Chain Financing Adoption.

INTRODUCTION

(Badan Pusat Statistik, 2022) Indonesia's economy has recorded a higher increase of 5.31 percent compared to the pre-Covid-19 pandemic period. This rapid economic growth in Indonesia is supported by a 5.47 percent growth in the manufacturing industry in the first quarter of 2022. The manufacturing industry has shown positive performance in the recovery efforts after being in the midst of a globally uncertain economic condition due to the threat of recession caused by the impact of the Covid-19 pandemic (Kementerian Perindustrian, 2022a). The sector that contributes significantly to the growth of the manufacturing industry is the transport equipment industry with a contribution of 14.20 percent, followed by the textile and garment industry with 12.45 percent, and the machinery and equipment industry with 9.92 percent. The textile and garment industry ranks second in contributing to the growth of manufacturing in Indonesia. This is due to its productive workforce playing a key role in improving logistics and the supply chain in Indonesia (Kemenko, 2021). However, there are several challenges faced by the textile and garment industry, which have experienced a decline in utilization in each subsector of the industry, resulting in an impact on the workforce, leading to layoffs (Kementerian Perindustrian, 2022b). The underperformance of the textile and garment industry will lead to a loss of competitiveness in the Indonesian industry. Numerous factory closures and disruptions in activities have affected the supply chain, making it unpredictable (Dovbischuk, 2022). Therefore, it is necessary to establish an entrepreneurial organization to assist organizations in developing innovation based on emerging market opportunities that are constantly changing. (Muta, 2013). In order to enhance competitiveness in Indonesia, the textile and garment industry needs to improve its entrepreneurial organization strategies by adopting a supply chain management approach. This will enable the industry to build sustainable performance and competitive advantages for the company (Manik et al., 2022). In order to enhance competitiveness in Indonesia, the textile and garment industry needs to improve its entrepreneurial organization strategy by adopting a supply chain management approach. This approach aims to build sustainable performance and competitive advantages for the company (Lu et al., 2020). Supply chain management activities aim to have a competitive advantage that can help reduce costs and enhance the competitiveness of the company (Kusumawati & Karjono, 2022).

In achieving competitive advantage for a company, it aligns with the Resource-Based View (RBV) theory, where the company is capable of managing a set of resources that complement each other and are difficult to imitate by competitors, thus enabling the company to sustain its competitive strategy (J. Barney, 1991). Companies involved in supply chain integration and supply chain financing adoption are influenced by the main factor of dynamic capabilities, where the company possesses innovation capabilities and the ability to perceive market response capabilities. This enables the company to quickly adapt to the changing environmental conditions (Chumphong et al., 2020).

The presence of innovation capabilities is a crucial step in the company's competitiveness process, as it drives the company's performance to achieve competitive advantage. This is one of the key factors for companies to enhance their ability to manage and create innovation in the long term (Mendoza-Silva, 2020). The presence of market



response capabilities is an effort by companies to quickly assess market demand and address market changes. If a company can accurately perceive market demand responses in a timely manner, it can enhance its performance by maintaining stable and strong customer relationships. (Lu et al., 2020). Therefore, high innovation capabilities can drive the competitiveness of companies in the supply chain network, while high market response capabilities can effectively and quickly meet market demands. Based on the issues faced by the textile and garment industry in Indonesia, this research aims to provide solutions to the problems related to the decline in utilization in each subsector of the textile and garment industry. Thus, this research is expected to assist textile and garment manufacturing stakeholders in achieving optimal competitiveness and performance.

1. CHAPTER – LITERATURE REVIEW

1.1 RBV (Resource-Based View)

The Resource-Based View (RBV) is used to examine the potential between a company's resources and sustainable competitive advantage by leveraging opportunities through its internal strengths and avoiding external threats and internal weaknesses (Barney, 1991).

1.2 Dynamic Capabilities

Dynamic capabilities refer to the process by which a company utilizes its resources and adapts its capabilities over time to respond to changing conditions, thereby maintaining long-term competitiveness (Ruiz-Ortega et al., 2023). Driving the utilization of specific competencies both internally and externally within a company to address changes can also be referred to as dynamic capabilities (Teece et al., 1997).

1.3 Supply Chain Management

Supply chain management is an essential part of every company, encompassing the planning, implementation, and control of logistics activities within a company (Attaran, 2020). Effective utilization of supply chain management will benefit the company in making informed decisions to achieve the proper functioning of the supply chain. (Fitri et al., 2019).

1.4 Entrepreneurial Organization

Entrepreneurial organization plays a role that is influenced by both internal and external factors of the organization (Diwanti et al., 2021). The implementation of entrepreneurial organizations is believed to be one of the key strategies to analyze the dynamics of the environment. If all members of the organization adopt entrepreneurial organization, it can drive the achievement of more effective and efficient supply chain management performance (Cortes et al., 2021).

2. CHAPTER – DESCRIPTIVE VARIABLES

2.1 Innovation Capabilities

Innovation capabilities refer to the efforts of a company to integrate capabilities and resources in order to stimulate change (Minh VU, 2020). In responding to rapidly changing market demands,

innovation capabilities are considered a crucial element in understanding the dynamics of change in the supply chain for competitive processes and the growth of a company. This can enhance performance and achieve sustainable competitive advantage. (Mendoza-Silva, 2020). The indicator of innovation capabilities according to (Songkajorn et al., 2020) are as follows:

1. Product innovation capability: It involves meeting customer needs by developing new markets and positioning the company's products according to the target market.
2. Process innovation capability: It provides the company with a competitive advantage by delivering clear benefits to customers and encouraging them to purchase the product.
3. Market innovation capability: It serves as a source of advantage and an important strategy that is often overlooked in relation to the company's market.

2.2 Market Response Capabilities

Market response capabilities are an organizational element that enables the organization to compete in responding to rapidly changing market demands (Garrett et al., 2009). The implementation of market response capabilities in an organization can enhance its sustainability and demonstrate its readiness to adapt to constantly changing market conditions (Luu, 2017). Therefore, if an organization has proactive capabilities to identify market changes and respond to market demands, it signifies that the organization possesses a higher level of market response. (Aljanabi & Ghafour, 2021). The indicators of market response capabilities, adapted from (Kohli et al., 1993) in relation to the market orientation scale, are as follows:

1. Intelligence generation: Gathering market demand and identifying market needs.
2. Intelligence dissemination: The process of sharing market information within an organization, both formally and informally.
3. Responsiveness: Taking action to respond to market demands based on speed and coordination within an organization.

2.3 Supply Chain Financing Adoption

Supply chain financing adoption is an effort to reduce unreasonable financial expenditures, which in turn impacts the performance and decision-making of the supply chain (Wang et al., 2020). The primary goal of optimizing supply chain financing adoption is to reduce the overall costs of the supply chain, particularly in terms of capital expenses. (Wang et al., 2020). The indicator of supply chain financing adoption according to (Caniato et al., 2016) are as follows:

1. Traditional financing: Involves low levels of digitalization in trade processes.
2. Innovative financing: Involves high levels of digitalization in trade processes with comprehensive analysis of the entire supply chain.
3. Supply chain collaborative: Optimizes working capital and focuses on inventory through collaboration among supply chain stakeholders.

2.4 Supply Chain Integration

Supply chain integration is an effort to encourage companies to create new value and strategies, thereby creating a competitive advantage for internal and external resources (Barney, J., 2012). The presence of supply chain integration can influence the performance of a company as it can reduce inefficiencies among supply chain partners and better meet market demand (Fernández, 2022). Supply chain integration is a key factor in improving supply chain performance and company performance. (Tiwari, 2021). The indicator of *supply chain integration* according to (Zhao et al., 2013) are as follows:



1. Supplier integration: It influences an organization's production activities in the face of industry competition dynamics.
2. Internal integration: It helps an organization in fostering customer satisfaction and trust across various aspects.
3. Customer integration: It involves interactions between customers and the company to build a relationship and gather up-to-date information regarding customer needs.

3. CHAPTER – RELATIONSHIP BETWEEN VARIABLES AND HYPOTHESES

3.1 Innovation Capabilities on Supply Chain Financing Adoption

In the textile and garment industry in Indonesia, innovation capabilities play a crucial role for companies in understanding the dynamics of change and driving organizational performance (Leo et al., 2022). High levels of innovation capabilities can enhance a company's competitiveness in the supply chain network, making it easier for the company to obtain funds through the utilization of supply chain financing adoption. (Lu et al., 2020). This is supported by previous research conducted by (Lu et al., 2020), which stated that innovation capabilities have an impact on supply chain financing adoption. It states that innovation capabilities have an impact on supply chain financing adoption. Based on the literature review above, the researcher proposes the following hypothesis:

H₁: Innovation capabilities have an impact on supply chain financing adoption.

3.2 Market Response Capabilities on Supply Chain Financing Adoption

In the textile and garment industry in Indonesia, market response capabilities also play a crucial role in optimizing supply chain financing adoption within a company. The objective is to meet customer demands more quickly and effectively, enabling the company to establish collaborations with relevant business networks more easily (Lu et al., 2020). With the presence of market response capabilities, companies are able to enhance their overall performance. (Chang et al., 2013). This is supported by previous research conducted by (Lu et al., 2020) which stated that market response capabilities have an impact on supply chain financing adoption. Based on the literature review above, the researcher proposes the following hypothesis:

H₂: Market response capabilities have an impact on supply chain financing adoption.

3.3 Innovation Capabilities on Supply Chain Financing Adoption Moderated by Supply Chain Integration

In the textile and garment industry in Indonesia, supply chain integration plays a crucial role in enhancing company competitiveness while optimizing operational and financial performance (Kalyar et al., 2020). The effective implementation of supply chain integration enables companies to leverage their strengths, thereby influencing innovation capabilities in relation to supply chain financing adoption (Lu et al., 2020). This is supported by the statement made by (Lu et al., 2020), which asserts that innovation capabilities have an impact on supply chain financing adoption moderated by supply chain integration. Based on the literature review above, the researcher proposes the following hypothesis:

H₃: Innovation capabilities have an impact on supply chain financing adoption moderated by supply chain integration.

3.4 Market Response Capabilities on Supply Chain Financing Adoption Moderated by Supply Chain Integration

In the textile and garment industry in Indonesia, supply chain integration also plays a crucial role in analyzing the dynamics of company integration, where companies are encouraged to integrate with other supply chain actors (Ramirez et al., 2021). The effective implementation of supply chain integration enables companies to gain competitive advantages and be easily identified, thereby influencing market response capabilities in relation to supply chain financing adoption (Lu et al., 2020). This is supported by the statement made by (Lu et al., 2020), which asserts that market response capabilities have an impact on supply chain financing adoption moderated by supply chain integration. Based on the literature review above, the researcher proposes the following hypothesis:

H₄: Market response capabilities have an impact on supply chain financing adoption moderated by supply chain integration.

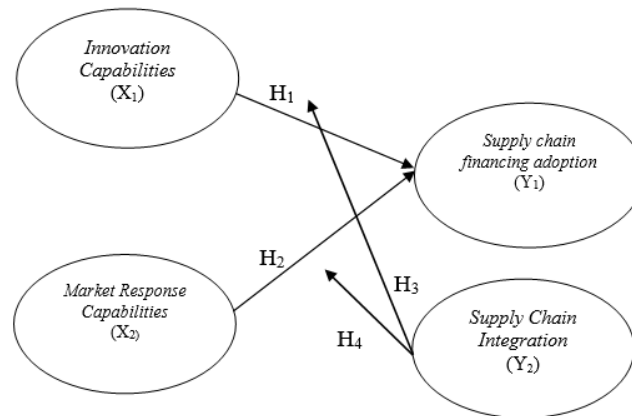

Figure 1. The conceptual research framework

4. CHAPTER – RESEARCH METHOD

A quantitative research was conducted with primary data obtained from two independent variables, namely innovation capabilities (X₁), market response capabilities (X₂), and two dependent variables, namely supply chain financing adoption (Y₁) and supply chain integration (Y₂), which were transformed into a questionnaire for survey purposes through the distribution of an e-questionnaire in the form of a Google Form. The respondents in this study were managers of textile and garment manufacturing companies in Indonesia who were members of the IPOMS (Indonesian Production & Operations Management Society) group, as IPOMS consists of a community of managers who are practitioners of supply chain management, ensuring a more accurate understanding compared to other supply chain practitioners.

The sample used in this study was determined using the Hair formula and random sampling method, where the existing indicators were multiplied by 10, resulting in a total of 10 x 12 (total number of indicators for all variables) = 120 samples. In this case, the minimum number of samples required to be obtained was 120 samples in order to be processed and analyzed (Hair et al., 2010). 7-point interval scale was used to measure each item (1 = "strongly disagree", 7 = "strongly agree") (Wibowo et al., 2023).

This research utilized Structural Equation Modeling (SEM) with the Partial Least Squares (PLS) method to obtain information regarding the influence of independent variables on dependent variables as moderations, which were conducted through the bootstrapping process (Nasution et al.,

2020). The SEM-PLS analysis consisted of three stages: outer model analysis, inner model analysis, and blindfolding analysis. The outer model analysis included convergent validity, discriminant validity, and reliability. The inner model analysis involved testing R-squared and F-squared, while the blindfolding analysis employed Q-squared testing.

5. CHAPTER – RESULT AND DISCUSSION

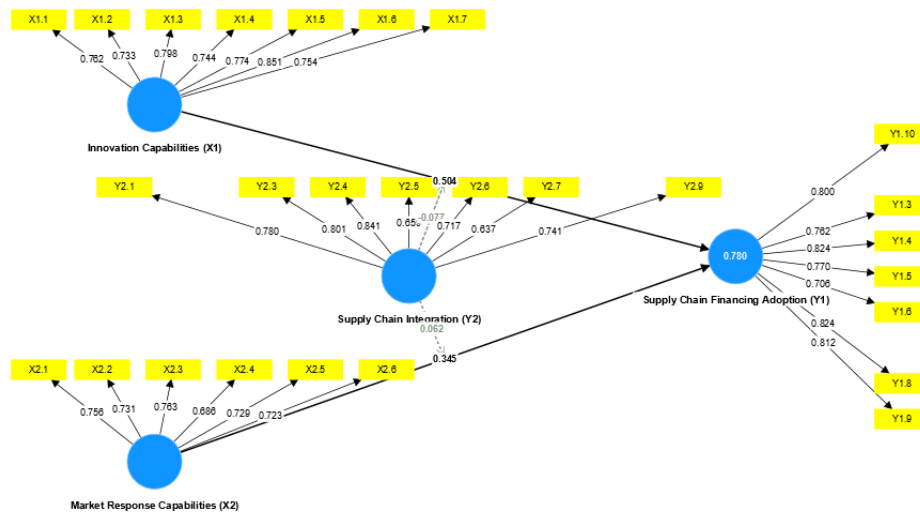

Figure 2. Outer Model

Table-1: Loading Factor, Cronbach’s Alpha, Composite Reliability, dan AVE

Item	Factor Loading	Cronbach’s Alpha	Composite Reliability	AVE
X1.1	0.762	0.888	0.892	0.600
X1.2	0.733			
X1.3	0.798			
X1.4	0.744			
X1.5	0.774			
X1.6	0.851			
X1.7	0.754			
X2.1	0.756	0.886	0.913	0.536
X2.2	0.731			
X2.3	0.763			
X2.4	0.686			
X2.5	0.729			
X2.6	0.723			
Y1.3	0.762	0.868	0.905	0.618
Y1.4	0.824			

**Accounting Inquiries with New Approaches in the Post-Pandemic Era
Volume I**

Y1.5	0.770			
Y1.6	0.706			
Y1.8	0.824			
Y1.9	0.812			
Y1.10	0.800			
Y2.1	0.780	0.917	0.932	0.551
Y2.3	0.801			
Y2.4	0.841			
Y2.5	0.659			
Y2.6	0.717			
Y2.7	0.637			
Y2.9	0.741			

Source: (Data diolah peneliti, 2023)

Based on Table 1, the results of the outer model analysis conducted using smartPLS 4.0 are as follows:

1. 1. Convergent Validity: it should have outer loading values > 0.7 , but values between 0.5 and 0.6 are still acceptable (Ghazali & Nordin, 2019). In this study, the outer loading values of each variable item have exceeded 0.6, indicating that it meets the criteria for convergent validity.
2. Discriminant Validity, it should have an Average Variance Extracted (AVE) value > 0.5 to indicate that the model is good (Hair et al., 2019). In this study, the AVE values are greater than 0.5, indicating that it has good discriminant validity.
3. Reliability Variable, it should have a Cronbach's alpha value greater than 0.6 and a composite reliability value greater than 0.7 (Hair et al., 2019). In this study, the Cronbach's alpha value is greater than 0.6 and the composite reliability is greater than 0.7, indicating good reliability.

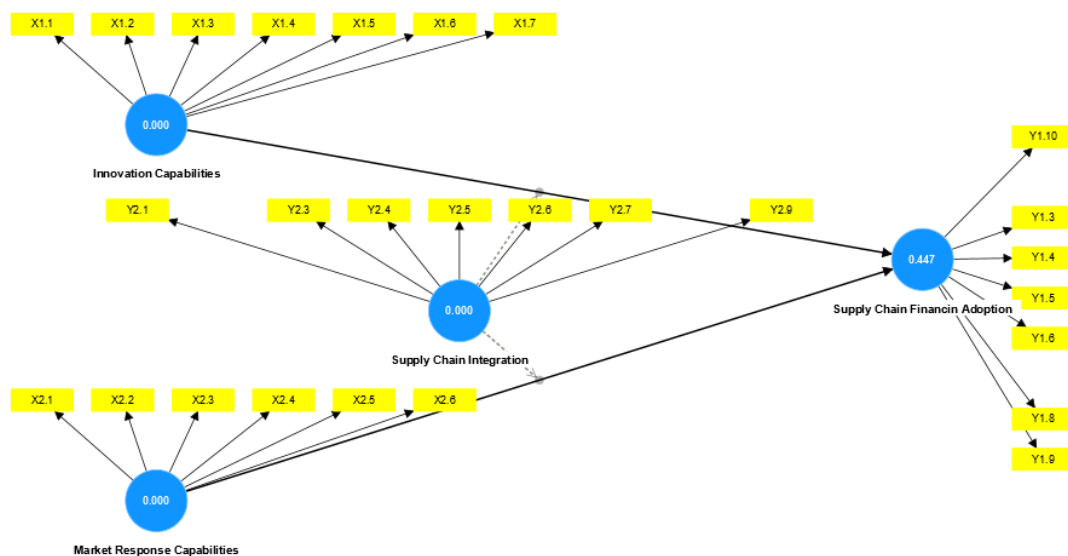



Figure 3. Blindfolding

Table-2: Q square (Q^2)

Variabels	Q^2	Category
<i>Innovation capabilities</i>	0.000	
<i>Market response capabilities</i>	0.000	
<i>Supply chain financing adoption</i>	0.447	Sedang
<i>Supply chain integration</i>	0.000	

Source: (The data was processed by the researcher, 2023)

Based on Table 2, to test the blindfolding using Q square (Q^2) measurement, this study has shown that the supply chain financing adoption variable has predictive relevance with a Q square value of 0.447. Therefore, it can be concluded that the supply chain financing adoption variable falls under the category of moderate predictive relevance because $Q \text{ square} > 0.25$.

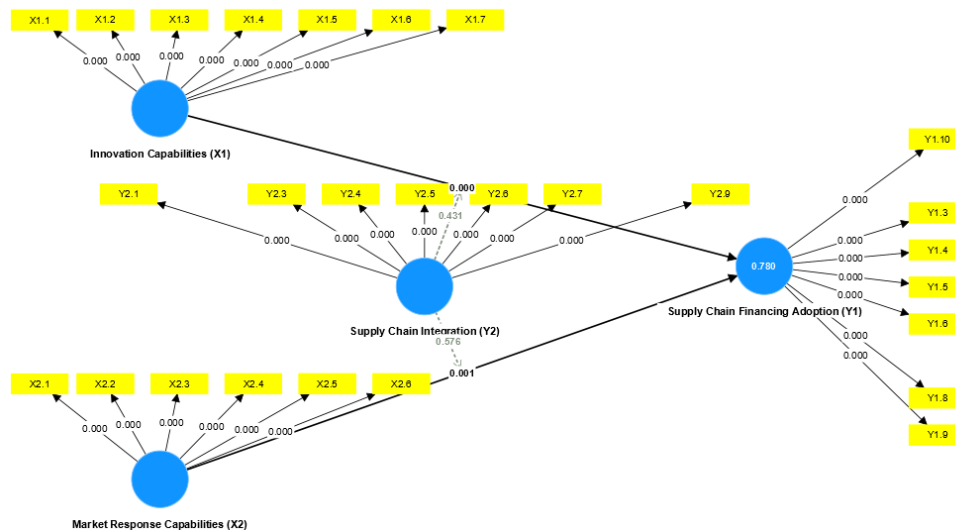

Figure 3. Inner Model

Table-3: R Square (R^2)

	IC	MRC	SCFA	SCI
R^2			0.780	

Source: (The data was processed by the researcher, 2023)

Based on Table 3, the R-squared value for the supply chain financing adoption variable is 0.780 or 78%. This means that the influence of innovation capabilities and market response capabilities on supply chain financing adoption in the textile and garment manufacturing industry accounts for 78%, while the remaining 22% is influenced by other variables not mentioned in this study.

Table-4: F Square (F^2) dan Hypothesis Testing

	F^2	O	M	STDEV	T statistic	P value

Accounting Inquiries with New Approaches in the Post-Pandemic Era
Volume I

<i>Innovation Capabilities (X₁) -> Supply Chain Financing Adoption (Y₁)</i>	0.264	0.504	0.500	0.121	4.172	0.000
<i>Market Response Capabilities (X₂) -> Supply Chain Financing Adoption (Y₁)</i>	0.132	0.345	0.349	0.105	3.292	0.001
<i>Supply Chain Integration (Y₂) x Innovation Capabilities (X₁) -> Supply Chain Financing adoption (Y₁)</i>	0.012	-0.077	-0.075	0.098	0.788	0.431
<i>Supply Chain Integration (Y₂) x Market Response Capabilities (X₂) -> Supply Chain Financing Adoption (Y₁)</i>	0.007	0.062	0.054	0.110	0.560	0.576

Source: (The data was processed by the researcher, 2023)

Based on Table 4, the F-square is used to determine the relative influence of independent variables on the dependent variable. In this study, a moderate relative influence is indicated by the influence of X₁ on Y₁ because $F^2 > 0.15$, while a small relative influence is indicated by the influence of X₂ on Y₁ because $F^2 > 0.002$. Values of $F^2 < 0.02$ can be ignored. In the hypothesis analysis, if the probability value has a significant level of $\alpha 5\% < 0.05$ and the T-Table value for $\alpha 5\%$ is 1.96, and if the p-value < 0.05 , it is considered significant. The following are the results of the hypothesis testing in this study:

H1: Innovation capabilities significantly influence supply chain financing adoption in the textile and garment manufacturing industry in Indonesia.

The first hypothesis tests the influence of innovation capabilities on supply chain financing adoption, with a calculated T statistic of 4.172, indicating that the T statistic > 1.96 . The p-value is 0.000, indicating that the p-value < 0.05 . Based on these results, it can be concluded that the first hypothesis is accepted because innovation capabilities significantly influence supply chain financing adoption in the textile and garment manufacturing industry in Indonesia.

H2: Market response capabilities significantly influence supply chain financing adoption in the textile and garment manufacturing industry in Indonesia.

The second hypothesis tests the influence of market response capabilities on supply chain financing adoption, with a calculated T statistic of 3.292, indicating that the T statistic > 1.96 . The p-value is 0.001, indicating that the p-value < 0.05 . Based on these results, it can be concluded that the second hypothesis is accepted because market response capabilities significantly influence supply chain financing adoption in the textile and garment manufacturing industry in Indonesia.

H3: Innovation capabilities do not significantly influence supply chain financing adoption in the moderation of supply chain integration in the textile and garment manufacturing industry in Indonesia.

The third hypothesis tests the influence of innovation capabilities on supply chain financing adoption in the moderation of supply chain integration, with a calculated T statistic of 0.788, indicating that the T statistic < 1.96 . The p-value is 0.431, indicating that the p-value > 0.05 . Based on these results, it can be concluded that the third hypothesis is rejected because innovation capabilities do not significantly influence supply chain financing adoption in the moderation of supply chain integration in the textile and garment manufacturing industry in Indonesia.

H4: Market response capabilities do not significantly influence supply chain financing adoption in the moderation of supply chain integration in the textile and garment manufacturing industry in Indonesia.

The fourth hypothesis tests the influence of market response capabilities on supply chain financing adoption in the moderation of supply chain integration, with a calculated T statistic of 0.560, indicating that the T statistic < 1.96 . The p-value is 0.576, indicating that the p-value > 0.05 . Based on these results, it can be concluded that the fourth hypothesis is rejected because market response capabilities do not significantly influence supply chain financing adoption in the moderation of supply chain integration in the textile and garment manufacturing industry in Indonesia. Berdasarkan Tabel 4 menunjukkan F square digunakan untuk melihat pengaruh relatif variabel independent terhadap variabel dependen. Pada penelitian ini, pengaruh relatif sedang ditunjukkan oleh pengaruh X_1 terhadap Y_1 karena $F^2 > 0.15$, pengaruh relative kecil ditunjukkan oleh pengaruh X_2 terhadap Y_1 karena $F_2 > 0.002$. Sedangkan untuk $F_2 < 0.02$ bisa diabaikan. Kemudian pada analisis hipotesis apabila nilai probabilitas memiliki tingkat signifikan alpha $5\% < 0,05$ dan nilai T-Tabel untuk alpha 5% adalah 1,96, serta nilai signifikansi jika p value $< 0,05$. Berikut adalah perolehan hasil pengujian hipotesis pada penelitian ini:

6. CHAPTER – DISCUSSION

The objective of this study is to examine the influence of innovation capabilities and market response capabilities on supply chain financing adoption, moderated by supply chain integration in the textile and garment industry in Indonesia.

The first hypothesis of this study aims to prove that innovation capabilities will enhance supply chain financing adoption. Based on previous research conducted by (Lu et al., 2020), the presence of innovation capabilities increases competitive advantages, thereby driving productivity and profitability through the implementation of supply chain financing adoption, which helps address financing issues. Innovation capabilities are a key factor for companies in implementing supply chain financing adoption. This is supported by (Wang et al., 2020), who explain that adopting supply chain financing can improve a company's financial performance throughout the supply chain. Additionally, (Teofilus et al., 2020) state that innovation capabilities can help organizations explore new markets by developing new services or products. The findings of this study are supported by previous research conducted by (Lu et al., 2020), which states that innovation capabilities have a positive and significant impact on supply chain financing adoption.

The second hypothesis of this study aims to prove that market response capabilities will enhance supply chain financing adoption. According to (Lu et al., 2020), high market response capabilities drive companies to meet market demands quickly and effectively through the implementation of supply chain financing adoption, which helps reduce financing costs along the supply chain process. Market response capabilities are a key factor for companies in implementing supply chain financing adoption. This is supported by (Wuttke et al., 2019), who explain that supply chain financing adoption can make supply chain financing more efficient. Furthermore, it is stated that innovation capabilities can enhance a company's long-term competitiveness (Mendoza-Silva, 2020). The findings of this study are supported by previous research conducted by (Lu et al., 2020), which states that market response capabilities have a positive and significant impact on supply chain financing adoption.

The third hypothesis of this study aims to prove that innovation capabilities will enhance supply chain financing adoption when supply chain integration is high. Based on research by (Kalyar et al., 2020), high supply chain integration stimulates higher innovation capabilities, leading supply chains to develop strategic planning internally and externally while implementing supply chain financing adoption to enhance financing efficiency (Wang et al., 2020). However, the findings of this study contradict this statement, indicating that supply chain integration does not have a positive moderating effect on the relationship between innovation capabilities and supply chain financing adoption. These findings are supported by previous research conducted by (Lu et al., 2020), which states that supply chain integration does not have a moderating effect on the relationship between innovation capabilities and supply chain financing adoption.

The fourth hypothesis of this study aims to prove that market response capabilities will enhance supply chain financing adoption when supply chain integration is high. According to (Wijayadne et al., 2021), supply chain integration enables companies to interact with external suppliers and customers and demonstrate leadership capabilities internally, leading to enhanced performance and market response capabilities to monitor market changes and varying demands (Aljanabi & Ghafour, 2021). This also affects supply chain financing adoption, as companies can minimize unreasonable financing that may affect their supply chain performance (Wang et al., 2020). However, the findings of this study contradict this statement, indicating that supply chain integration does not have a positive moderating effect on the relationship between market response capabilities and supply chain financing adoption. These findings are supported by previous research conducted by (Lu et al., 2020), which states that supply chain integration does not have a moderating effect on the relationship between market response capabilities and supply chain financing adoption.

CONCLUSION

The study concludes that innovation capabilities and market response capabilities have a significant influence on supply chain financing adoption, while supply chain integration does not moderate the relationship between innovation capabilities and market response capabilities on supply chain financing adoption.

High innovation capabilities and market response capabilities can optimize supply chain financing adoption in manufacturing companies, reducing undue financing and lowering cost



expenditures in the supply chain process from upstream to downstream. However, it is recommended for companies to further optimize supply chain integration to facilitate both internal and external coordination, thereby driving supply chain performance and meeting market demand. For future researchers interested in conducting studies, it is suggested to explore other variables beyond the ones examined in this study (i.e., innovation capabilities and market response capabilities) that may have an influence on supply chain financing adoption. Researchers hope that future studies can have a different and broader scope beyond the population of this study.

REFERENCES

- Aljanabi, A. R. A., & Ghafour, K. M. (2021). Supply Chain Management and Market Responsiveness: a Simulation Study. *Journal of Business and Industrial Marketing*, 36(1), 150–163.
- Attaran, M. (2020). Digital Technology Enablers and Their Implications for Supply Chain Management. *In Supply Chain Forum* (Vol. 21, Issue 3, pp. 158–172). Taylor and Francis Ltd.
- Badan Pusat Statistik. (2022). *Ekonomi Indonesia Tahun 2022 Tumbuh 5,31 Persen*. <https://www.bps.go.id/pressrelease/2023/02/06/1997/ekonomi-indonesia-tahun-2022-tumbuh-5-31-persen.html>
- Barney, J. (1991). Firm Resources and Sustained Competitive Advantage. *Journal of Management*, 17(1), 99–120.
- Barney, J. B. (2012). *Purchasing, Supply Chain Management and Sustained Competitive Advantage: The Relevance of Resource-Based Theory*.
- Caniato, F., Gelsomino, L. M., Perego, A., & Ronchi, S. (2016). Does Finance Solve The Supply Chain Financing Problem? *Supply Chain Management*, 21(5), 534–549.
- Chang, S., Gong, Y., Way, S. A., & Jia, L. (2013). Flexibility-Oriented HRM Systems, Absorptive Capacity, and Market Responsiveness and Firm Innovativeness. *Journal of Management*, 39(7), 1924–1951.
- Chumphong, O., Srimai, S., & Potipiroon, W. (2020). The Resource-Based View, Dynamic Capabilities and SME Performance for SMEs to Become Smart Enterprises. *In ABAC ODI Journal Vision. Action. Outcome* (Vol. 7, Issue 2).
- Cortes, A. F., Lee, Y., Cortes, J. D., & Liñan, I. (2021). Entrepreneurial Orientation in Supply Chain Management: A Systematic Review. *International Journal of Entrepreneurial Knowledge*, 9(1), 127–143.
- Diwanti, D. P., Suryanto, S., Iswati, S., Agustina, T. S., & Notobroto, H. B. (2021). The Effect of Organizational Culture and Readiness to Change on Organizational Entrepreneurship: The Role of Competence. *Jurnal Manajemen Bisnis*, 12(2), 248–265.
- Dovbischuk, I. (2022). Innovation-Oriented Dynamic Capabilities of Logistics Service Providers, Dynamic Resilience and Firm Performance During The COVID-19 Pandemic. *International Journal of Logistics Management*, 33(2), 499–519.
- Fernández, J. T. (2022). Dependence and Resource Commitment as Antecedents of Supply Chain Integration. *Business Process Management Journal*, 28(8), 23–47.
- Fitri, H., Tyaz Nugraha, A., Yakub, A., & Priyo Cahyono, B. (2019). The Application of Agency Theory in Supply Chain Finance: A Case of Indonesian Manufacturing Firms. *In Int. J Sup. Chain. Mgt* (Vol. 8, Issue 3).
- Garrett, R. P., Covin, J. G., & Slevin, D. P. (2009). Market Responsiveness, Top Management Risk Taking, and The Role Of Strategic Learning as Determinants of Market Pioneering. *Journal of Business Research*, 62(8), 782–788.
- Hair, J. F., Black, W. C., & Babin, B. J. (2010). *Multivariate Data Analysis: A Global Perspective*.
- Hair, J. F., Risher, J. J., Sarstedt, M., & Ringle, C. M. (2019). When to Use and How to Report The Results of PLS-SEM. *In European Business Review* (Vol. 31, Issue 1, pp. 2–24). Emerald Group Publishing Ltd.
- Kalyar, M. N., Shafique, I., & Ahmad, B. (2020). Effect of Innovativeness on Supply Chain Integration and Performance: Investigating the Moderating Role of Environmental Uncertainty. *International Journal of Emerging Markets*, 15(2), 362–386.
- Kementerian Koordinator Bidang Perekonomian Republik Indonesia. (2021, March 9). *SDM Jadi Kunci Utama Kemajuan Logistik dan Rantai Pasok Nasional*. <https://www.ekon.go.id/publikasi/detail/2447/sdm-jadi-kunci-utama-kemajuan-logistik-dan-rantai-pasok-nasional>
- Kementerian Perindustrian. (2022a, May 9). *Laju Sektor Manufaktur Lampau Pertumbuhan Ekonomi*. <https://kemenperin.go.id/artikel/23315/Laju-Sektor-Manufaktur-Lampau-Pertumbuhan-Ekonomi>
- Kementerian Perindustrian. (2022b, November 8). *Tumbuh 4,83 Persen, Sektor Industri Paling Moncer di Triwulan III-2022*. Kementerian Perindustrian Republik Indonesia.

- <https://kemenperin.go.id/artikel/23683/Tumbuh-4,83-Persen,-Sektor-Industri-Paling-Moncer-di-Triwulan-III-2022>
- Kohli, A. K., Jaworski, B. J., & Kumar, A. (1993). MARKOR: A Measure of Market Orientation. *Source: Journal of Marketing Research*, 30(4), 467–477.
- Kusumawati, E. D., & Karjono, K. (2022). Integrasi Supply Chain dan Kinerja Perusahaan Manufacturing dan Logistik Pasca Pandemi Covid 19. **Proceeding of National Seminar on Maritime and Interdisciplinary Studies**, 1(1), 24–34.
- Leo, R. M., Camboim, G. F., Avila, A. M. S., Reichert, F. M., & Zawislak, P. A. (2022). Innovation Capabilities in Agribusiness: Evidence from Brazil. **RAUSP Management Journal**, 57(1), 65–84.
- Lu, Q., Liu, B., & Song, H. (2020). How Can SMEs Acquire Supply Chain Financing: The Capabilities and Information Perspective. **Industrial Management and Data Systems**, 120(4), 784–809.
- Luu, T. (2017). Market Responsiveness: Antecedents and The Moderating Role of External Supply Chain Integration. **Journal of Business and Industrial Marketing**, 32(1), 30–45.
- Manik, D. R., Sinulingga, S., & Ishak, A. (2022). Impact of Supply Chain Integration on Business Performance: A Review. **Jurnal Sistem Teknik Industri (JSTI)**, 24(1).
- Mendoza-Silva, A. (2020). Innovation Capability: a Systematic Literature Review. **In European Journal of Innovation Management** (Vol. 24, Issue 3, pp. 707–734). Emerald Group Holdings Ltd.
- Minh VU, H. (2020). A Review of Dynamic Capabilities, Innovation Capabilities, Entrepreneurial Capabilities and Their Consequences. **The Journal of Asian Finance, Economics and Business**, 7(8), 485–494.
- Muta, C. (2013). *The Entrepreneurial Organization What it is and Why it Matters*.
- Nasution, M. I., Fahmi, M., Jufrizen, Muslih, & Prayogi, M. A. (2020). The Quality of Small and Medium Enterprises Performance Using the Structural Equation Model-Part Least Square (SEM-PLS). **Journal of Physics: Conference Series**, 1477(5).
- Ramirez, M. J., Roman, I. E., Ramos, E., & Patrucco, A. S. (2021). The Value of Supply Chain Integration in The Latin American Agri-Food Industry: Trust, Commitment and Performance Outcomes. **International Journal of Logistics Management**, 32(1), 281–301.
- Ruiz-Ortega, M. J., Rodrigo-Alarcón, J., & Parra-Requena, G. (2023). New Directions to Create Dynamic Capabilities: The Role of Pioneering Orientation and Interorganizational Relationships. **European Management Journal**.
- Songkajorn, Y., Aujirapongpan, S., Deelers, S., Rakthai, T., & Jutidharabongse, J. (2020). Innovation Capability Indicators for Entrepreneurs Developed the Business from Thai University Incubator. **Journal of Southwest Jiaotong University**, 55(6).
- Teece, D. J., Pisano, G., & Shuen, A. (1997). Dynamic Capabilities and Strategic Management. **In Strategic Management Journal** (Vol. 18, Issue 7).
- Teofilus, T., Singh, S. K., Sutrisno, T. F., & Kurniawan, A. (2020). Analyzing Entrepreneurial Marketing on Innovative Performance. **Mix Jurnal Ilmiah Manajemen**, 10(1), 78.
- Tiwari, S. (2021). Supply Chain Integration and Industry 4.0: a Systematic Literature Review. In *Benchmarking* (Vol. 28, Issue 3, pp. 990–1030). Emerald Group Holdings Ltd.
- Wang, Z., Wang, Q., Lai, Y., & Liang, C. (2020). Drivers and Outcomes of Supply Chain Finance Adoption: An Empirical Investigation in China. **International Journal of Production Economics**, 220.
- Wibowo, A. T., Sutrisno, T. F., & Kenang, I. H. (2023). The Role of Soft Total Quality Management Towards Operational Performance at PT SIER. **Jurnal Aplikasi Bisnis Dan Manajemen**.
- Wijayadne, D. R., Sutrisno, T. F., Henryanto, A. G., & Pasaribu, B. D. (2021). *The effect of Supply Chain Practices on Business Performance in PT.Putra Tunggal Perkasa*. 19(1).
- Wuttke, D. A., Rosenzweig, E. D., & Heese, H. S. (2019). An Empirical Analysis of Supply Chain Finance Adoption. **Journal of Operations Management**, 65(3), 242–261.
- Zhao, li, Huo, B., Sun, L., & Zhao, X. (2013). The Impact of Supply Chain Risk on Supply Chain Integration and Company Performance: a Global Investigation. **Supply Chain Management: An International Journal**, 18(2), 115–131.

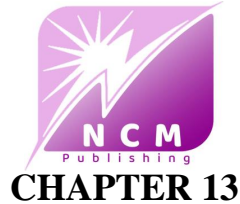

The Effect of Using Sap in Business Intelligence

Yohana Oktavia

Bhayangkara Jakarta Raya University, Indonesia
202120152004@mhs.ubharajaya.ac.id
Orcid: 0009-0004-7889-3010

Yonathan Hakim

Bhayangkara Jakarta Raya University, Indonesia
202120152006@mhs.ubharajaya.ac.id
Orcid: 0009-0008-3141-4966

Mrs. Dewi Puspaningtyas Faeni

Bhayangkara Jakarta Raya University, Indonesia
Dewi.puspaningtyas@dsn.ubharajaya.ac.id
Orcid: 0000-0002-1911-4425

ABSTRACT

Business Intelligence is a data analysis reporting and data search tool that can help business users manage abundant data to make the data as information used in decision making. To get a decision by applying Business Intelligence, a support system called an expert system is needed. Expert System can help increase good knowledge and productivity by utilizing a technology tool called SAP (System Application and Processing). SAP is an application used by many companies to integrate or combine into one of the company's various problems that are very complex. SAP is widely used in various fields ranging from Sales and Distribution, Material Management, Production Planning, Quality Management, Planning Maintenance, Human Resource Management, Financial Accounting, Controlling, Asset Management, Project System.

Keywords: Business Intelligence, Expert System, SAP

INTRODUCTION

With increasing business competition, increasing speed with changing market conditions and customer needs, companies face new challenges. In the long run companies can adapt to conditions that can respond flexibly and quickly to changes while keeping their costs under control. Business Intelligence can describe approaches such as collecting, storing, processing, analysing and presenting enterprise data. Business Intelligence tools are getting cheaper and more affordable for enterprises. For examples the Business Intelligence market is saturated by software vendors such as SAP. The purpose of this paper is to look at the relevance of using SAP as an expert system in Business Intelligence and being a suitable solution for large companies and start-up (Faeni, 2022).

THEORITIS

Business Intelligence

Business Intelligence is a data analysis, reporting, and retrieval tool that can help business users manage abundant data to make it informative for decision making (Anandarajan, Srinivasan, 2004). Business Intelligence software denotes software products that are primarily designed to support analytical processes (e.g.data warehouse software, digital dashboard software). Business Intelligence can also be defined as a rational application of intelligence principles including the collecting, analysis, and application of any strategic information in business decision making (Marren, 2005).

Business Intelligence system involve 5 basic intelligence tasks, namely collecting data, evaluating data, analyzing data, storing intelligence, and disseminating intelligence (McLeod, 2007). In particular, the distinction between internal and external systems must be made as a source. Through data integration, the required data is transferred from the initial system, processed and condensed which is referred to as the ETL process. The purpose of the ETL process is to ensure that the data has been processed can be stored (Faeni et, al 2022).

Business Intelligence also involves using information technology and data analysis tools to extract information from various data sources, including transaction data, customer data, and industry data. The results of this analysis are then used to provide better insights into business performance, market trends, and business opportunities.

The following figure provides an overview of each process and shows which component belong to which process step.

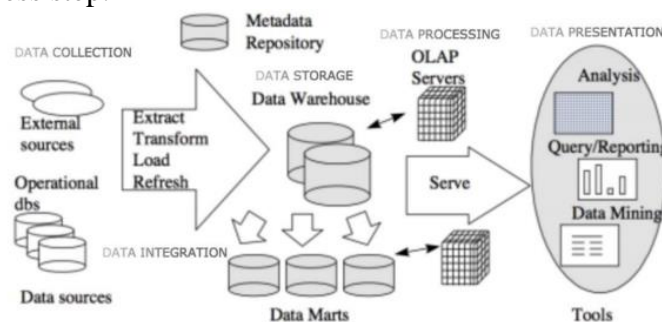

Figure 1. Business Intelligence Process (Wang, J., Chen, T. dan Chiu, S. (2005))

Purpose of Business Intelligence

Business Intelligence as a support for decision making. Business Intelligence has three main objectives, namely:

- Improved decision basis: Decision are usually made based on the information available. The use of Business Intelligence can e summarized into a format that provides an informational advantage in day-to-day work.
- Increase transparency of company actions: With Business Intelligence, employees have responsibility for their work areas though facts and figures of operations and opportunity to increase that visibility of the company as a whole.
- Showing the relationship between stand-alone information: In this case Business Intelligence aims to integrate data from various sources and recognize relationships that cannot be obtained from the information sources considered individually.

EXPERT SYSTEM (EsSs)

Expert System is a computer system that equals the decision-making ability of an expert (Ahrami, 2005). Expert System is also defined as an intelligent computer program that uses knowledge and inference procedures to solve problems that area difficult enough to require an expert to solve them (Fieganbaum, 1982:1).

Expert System Structure

Expert System is organized into two parts, namely the development environment and the consultation environment. The expert system development environment is used to input expert knowledge into the expert system, while the consultation environment is used by non-expert users to obtain expert knowledge.

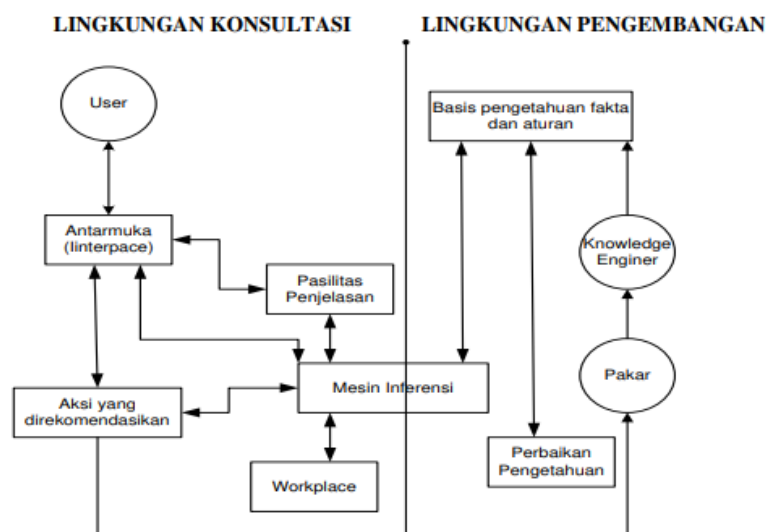

Figure 2. Expert System Architecture (Turban, 1995)

Pros and Cons of Expert System

Broadly speaking, there are many advantages obtained with the expert system, including:

- a. Makes Knowledge and advice more readily available
- b. Increase output and productivity
- c. Store expert skills and expertise
- d. Improving problem solving
- e. Improving reliability
- f. Provide a quick response (answer)
- g. Is an Intelligence guide
- h. Can work with incomplete information and uncertainly
- i. Database intelligence, that expert system can be used to access database in an intelligent way.

In addition to the above advantages, the expert system also has weaknesses including:

- a. Problems in obtaining knowledge where knowledge cannot always be obtained easily.
- b. To create a truly high-quality expert system is difficult and requires enormous costs for development and maintenance.
- c. The system cannot make decisions
- d. Expert systems are not 100% profitable. Therefore, it needs to be carefully retested before use.

The weaknesses of this expert system can be overcome by making improvements and management based on existing experience with a long time and continuously.

Expert System Objectives

Expert System has the ability to recommend a series of usage actions to be able to run a proper and accurate correction system. Here are some of the goals of using an *expert system*: (cari dapus lestari, 2012)

- a. Interpretation : Expert System aims to make a conclusion from a set of raw data.
- b. Prediction : With the Expert System it is possible to project the consequences of certain situations and conditions.
- c. Diagnosis : Diagnosis can determine the cause of malfunctions in complex situations based on observable symptoms with proper diagnosis.
- d. Design : Expert System can create designs according to objects.
- e. Design : Design is able to determine and design configurations related to system components that match performance goals that can meet certain constraints.
- f. Planning : Expert System aims to plan a set of actions that gets the goal at a certain stage of initial conditions.
- g. Monitoring : Make observations based on an expected condition.
- h. Debugging : Able to determine and interpret ways to prevent malfunctions or failures of certain features.
- i. Instructions : Has the ability to detect the level of efficiency towards understanding



the subject domain.

- j. Control : Possess the skills to regulate the behavioral patterns of a complex environment.
- k. Monitoring : Make observations based on an expected condition.
- l. Debugging : Able to determine and interpret ways to prevent malfunctions or failures of certain features.
- m. Instructions : Has the ability to detect the level of efficiency towards understanding the subject domain.
- n. Control : Possess the skills to regulate the behavioral patterns of a complex environment.

SYSTEM ANALYSIS and PRODUCT in DATA PROCESSING (SAP)

SAP is a System Application and Processing which is one of the applications used by many companies to carry out an integration or combine into one of various very complex company problems.

SAP is able to perform a variety of functions according to company objectives. This application consists of several large programs that are complemented by sub-programs. When the SAP program operates, SAP has certain functions including functions in several fields in the company such as:

- a. Sales and Distribution, which assists in the efficiency of activities related to the customer order management process. Sales and Distribution's role is to improve the efficiency of every operational activity for the shipping, sales, and billing process for every order from consumers.
- b. *Material Management* has a function in terms of the financing process as well as inventory management in the warehouse.
- c. *Production Planning* is assisting in the process of planning and controlling the company's production activities.
- d. *Quality Management* functions to analyze the process quality of the entire logistics chain.
- e. *Planning Maintenance* is a solution for administrative processes and technical system repairs.
- f. *Human Resource Management* has a function to handle employee registration and administration applications as well as time management and financing for travel to employee payroll.
- g. *Financial Accounting*
Financial Accounting includes standard accounting cash management, general ledger and consolidation for financial reporting. *Financial Accounting* will work to consolidate all company financial reports. In this case, the entire process will be done in one system, which is certain that all data will be more easily integrated and minimize calculation errors.
- h. Controlling has a function to assist the cost accounting process starting from cost center accounting and cost element accounting to profitability analysis. Controlling

will control and monitor all activities and data management for each division.

- i. *Asset Management* has a function to simplify the management process of all fixed
- j. assets, which includes the traditional asset accounting process and technical asset management to investment controlling.
- k. *Project System* has a function to integrate all the project planning processes of workmanship control.

Benefits of SAP for Companies

Impact of SAP Integration

By using SAP, changes made to one module will automatically update other modules if the changed information is still related to that module. And it will be updated directly after the user enters data into the system which is often called real time processing integration which makes the system can be connected to all company computers that use the same resources. This allows the transfer of information covered in one document to another document so that it will reduce the work in data input.

Implementation of SAP

There are 3 benefits of implementing SAP in the company, such as:

- a. Increase the speed of business processes
 - Improve customer service
 - Improve market change response
- b. Improve consistency of business processes
 - Ensure that SOPs are running properly
 - Improved monitoring function
 - Reduce human errors
- c. Improve the quality of the process
 - Improve the ability to make decisions quickly and accurately
 - Improved analysis function

Usefulness of SAP

SAP has uses in the company, including:

- a. Improve customer service

By using SAP in the company, business owners can get all the data completely, from pre- production to post-production. This will be used as a provision of concrete information on consumer response, market trend conditions, and existing competition. Thus, business actors can take concrete steps to improve customer service for the better.

- b. More efficient production planning



Through SAP software, the product planning process will also be more efficient, because all data is available automatically.

c. Monitoring Efficiency

One of the biggest advantages that can be obtained by utilizing SAP is efficiency in terms of monitoring. Companies can monitor all divisions with just one tool that has been automatically integrated. This will be very beneficial for large companies with many different divisions.

d. Improved Company Data Security

Data security is one of the most important SAP software features. ERP systems improve data quality and accuracy, and provide better data protection through firewalls and internal security system.

DISCUSSION

The use of Business Intelligence in retail companies is needed mainly for data integration, storing data, data preparation or data analysis and for presenting data. Thus Business Intelligence becomes the basis for making decisions within the company. Business Intelligence can be a systematic solution where data that was previously processed manually will be extracted and done automatically. This can help employees to reduce the risk of making mistakes and can traceability (traceability system) which makes it less likely that data can be manipulated. One form of Business Intelligence provision is SAP (System Application and Processing) which is a computer system that provides different features of Business Intelligence needs. SAP itself has part of the 10 objectives of the expert system but the drawback of SAP is that this tool can only be operated by users who are experts or experienced.

CONCLUSIONS

SAP is ERP software that helps companies manage business processes and operations. With the modules provided, SAP can improve business speed, consistency, and quality. In its implementation, SAP can reduce the risk of errors, increase efficiency, and improve customer service. SAP is an important style for companies that want to optimize their business processes but in SAP there are still shortcomings, namely not being able to do debugging so that when SAP is down it causes the application to not be used until SAP has been repaired and in terms of usage only for some expert users who can operate the SAP.

REFERENCES

- Anandarajan, M., Srinivasan, C.A. and Anandarajan, A. (2004), Business Intelligence Techniques, Springer Verlag, Berlin Heidelberg, 2004.
- Bratha, Wayan Gede Endra., Mega Aswiputri., Dewi Puspaningtyas Faeni. (2022). Business Intelligence Strategy Wins Market Competition (Case Study on Video Streaming Platform Products). International CEO

Accounting Inquiries with New Approaches in the Post-Pandemic Era
Volume I

- (Communication, Economics, Organization), Vol. 5 (680). 978-605-73822-7-6.
<http://congress5.ceocongress.org/en>
- Faeni, Dewi Puspaningtyas. (2015). HRM Practices and Existence of Knowledge Management Agent in Higher Education, Information and Knowledge Management, 5(3) 2224-5758.
<https://www.iiste.org/Journals/index.php/IKM/article/view/20581>
- Faeni, Dewi Puspaningtyas., Ratih Puspitaningtyas Faeni, (2016) Cognitive Style and Composition of Employees in Shaping Intellective Sales Team. Business Economig Social Science Humanities Conference (BESSH). Volume 11. September 2016.. Willey Publisher.
- Faeni, Dewi Puspaningtyas., Ratih Puspitaningtyas Faeni, (2016) Manager Characteristics, HR Renewal, Marketing Strategies, Partnership Motivation, Work Orientation, Work Standardization, on SMES Business Resilience in the Competition: Insurance Healthcare Services. Scholedge International Journal of Management & Development Volume 3, Issue 2. Pages 32-48 Publisher. Scholedge the Scholarly Publishing
- Faeni, Dewi Puspaningtyas., Ratih Puspitaningtyas, (2020) The Role Of Management Control System On Firm Performance. Talent Development & Excellence, 12(1), 1629-1639. <http://www.iratde.com/>
- Faeni, Dewi Puspaningtyas., Ratih Puspitaningtyas, Yuliansyah Yuliansyah. (2022). The COVID-19 Pandemic Impact on the Global Tourism Industry SMEs: A Human Capital Development Perspective. Review of International Business and Strategy, 32(4), 2059-6014. <https://doi.org/10.1108/RIBS-08-2021-0116>
- Faeni, Dewi Puspaningtyas., Wastam Wahyu Hidayat., Ery Teguh Prasetyo., Ratih Puspitaningtyas Faeni. (2022). Price, E-Servqual Cose To Customer Satisfaction (Study Case of Online Application in Indonesia). International CEO (Communication, Economics, Organization), Vol. 5. (1093). 978-605-73822-7-6.
<http://congress5.ceocongress.org/en>
- Faeni, Dewi Puspaningtyas., Yudi Nugroho. (2017) The Role Of Women Entrepreneurs Leadrships, Social Capitaland Absorptive Capacity Through Skills Upgrading Concept In Small To Medium Enterprises In Jakarta, Indonesia. International Journal of Pure and Applied Mathematics, 116(24), 511-520.
<http://www.ijpam.eu/>
- Harsono., Mega Aswiputri., Dewi Puspaningtyas Faeni. (2022). Business Intelligence A Literature Study. International CEO (Communication, Economics, Organization), Vol. 5 (1759). 978-605-73822-7-6.
<http://congress5.ceocongress.org/en>
- Indrawati, Iin., Suparman Hi Lawu., Dewi Puspaningtyas Faeni. (2022) Business Intelligence Benefits Development at University. International CEO (Communication, Economics, Organization), Vol. 5 (1667). 978-605-73822-7-6. <http://congress5.ceocongress.org/en>
- Marren, P. 2005. The Father of Business Intelligence, The Journal of Business Strategy, Vol.25 No 6, pp. 5 - 7.
- Marundha, Amor., Dewi Puspaningtyas Faeni. (2022). Ceo Overconfidence, Profitability, And Corporate Social Responsibility on Tax Avoidance. International CEO (Communication, Economics, Organization), Vol. 5 (962). 978-605-73822-7-6. <http://congress5.ceocongress.org/en>
- McLeod, R. 2007. Management Information Systems, 10th Edition, Prentice Hall.
- Primawanti, Eka Putri., Tatin Rusmayanti Ardiyani., Dewi Puspaningtyas Faeni. (2022). Benefits And Constraints in Business Intellegence. International CEO (Communication, Economics, Organization), Vol. 5 (1674). 978-605-73822-7-6. <http://congress5.ceocongress.org/en>
- Sudarso, Alek., Sri Wahono., Dewi Puspaningtyas Faeni. (2022). Utilizing Business Intelligence for Decision Making in Winning Market Competition. International CEO (Communication, Economics, Organization), Vol. 5 (674). 978-605-73822-7-6. <http://congress5.ceocongress.org/en>
- Turban, Efraim. 1995. Decision Support System and Expert System. Prentice Hall International, New Jersey.
- Wang, J., Chen, T. and Chiu, S. (2005), Literature Review on Data Warehouse Development. IACIS Pacific 2005 Conference Program, National Chengchi University, pp.987- 994.

The Impact of Environmental, Social, and Governance Performance on The Financial Health and Firm Value of The Publicly Listed Firms at Indonesia Stock Exchange

Riko RANGKUTI

Sekolah Tinggi Manajemen IPMI, Indonesia
riko.rangkuti@ipmi.ac.id
Orcid: 0009-0007-5803-6013

Roy H. M. SEMBEL

Sekolah Tinggi Manajemen IPMI, Indonesia
roy.sembel@ipmi.ac.id
Orcid: 0000-0002-9023-9976

Melinda MALAU

Universitas Kristen Indonesia, Indonesia
melinda.malau@uki.ac.id
Orcid: 0000-0002-6576-3063

ABSTRACT

During the last decade, companies have increasingly enhanced corporate sustainability by targeting Environment, Social, Governance (ESG), and financial objectives. Several studies highlight the benefits of ESG on financial performance and stock return. However, the effect of ESG on overall firm risk still remains an open debate. This study examines the impact of ESG performance on the financial health and firm value of publicly listed firms at the Indonesia Stock Exchange. We hypothesize that ESG performance positively affects financial health and firm value. The research method uses a quantitative approach by observing ESG performance from the KEHATI foundation and financial reports of the publicly listed firms as secondary data sources. The samples use the 40 cross-sectional selected firms and 6 semesters selected time series balanced data for a period of 2019 to 2021 which form a 240 samples observation. The measurement of variables is the ESG performance pillar scores, financial health proxied by Altman Z-score, financial performance, and firm value proxied by Tobin's Q score. The equations use a panel data regression model. The tool uses EViews 12 software for general statistical analysis and econometric analyses. Our findings are the ESG pillars scores have a high correlation among themselves, individually has an insignificant effect on Altman Z-score and Tobin's Q, and jointly have an insignificant effect and very low relationship to Altman Z-score and Tobin's Q. Furthermore, Altman Z-score has insignificant effect as the mediating variable to Tobin's Q. Overall, we conclude that ESG performance does not have a significant effect to the financial health and firm value.

Keywords: ESG performance, environment social governance, financial health, financial performance, firm value

INTRODUCTION

Background

Environmental, Social and Governance (ESG) is one of the fastest growing trends in business and finance and is transforming how companies need to communicate. It has become necessary for companies to adequately communicate their ESG performance to stakeholders ranging from investors and regulators to clients and employees.



Figure-1: ESG Pillars

Sources: <https://www.techtarget.com>

In environment, the main issue is the usage of fossil fuel energy which cause increase of carbon and other gas emission and create a greenhouse effect at the atmosphere. Earth temperature has increase 1.2 degree and make the climate change. Other issues are waste reduction and management, and biodiversity loss. In social, the issues are employment and wages, workplace health and safety and community engagement. In governance, the issues are risk management, ethical business practice, avoid conflict of interest, accounting integrity and transparency.

Environment, Social, and Governance or ESG is one of the fastest growing trends in business and finance and is transforming how companies need to communicate. This trend become the stakeholders interest ranging from investors and regulators to clients and employees. Since it was first introduced, ESG trends is growing fast as indicated by the total Asset Under Management or AUM from 6 trillion US Dollar and 23 signatories in 2004 to 103.4 trillion US Dollar and 3038 signatories in 2020. With growing action from governments, companies and investors, ESG consideration will be included in all of investment decisions.

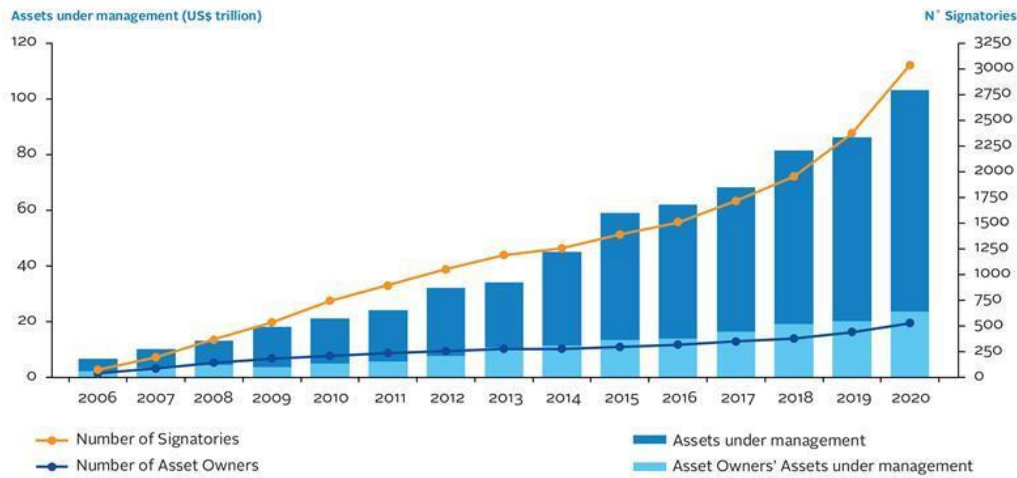

Figure-2: ESG Assets Under Management

Sources: <https://www.unpri.org>

Harvard Business School tested the performance of a sample of 90 companies that had adopted sustainability policies since the early 1990.

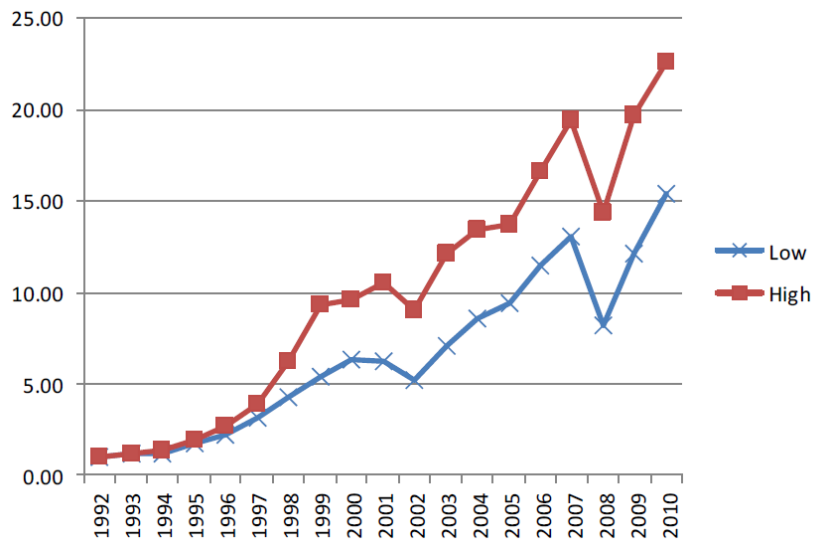

Figure-3: ESG Market Performance

Source: (Eccles et al., 2014)

The key finding of the research was that in the 18-year period studied. Stocks of high sustainable firms perform better than those of less sustainable firms. The evolution of \$1 invested in the stock market in a value-weighted portfolio. The high sustainability firms outperformed the low sustainability ones in terms of both stock market and accounting measures.

According to a review by Friede et al., in 2015 of over 2000 empirical studies, including review studies, 90 percent of the studies found a nonnegative ESG-CFP (Corporate Financial Performance) and a large majority of these studies report positive findings.

Result of > 2,000 studies on the impact of ESG propositions on equity return

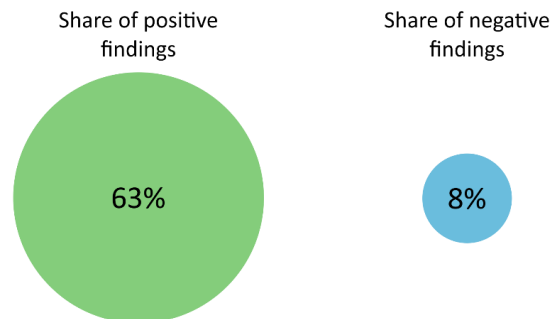

Figure-4: Aggregated Evidence from More Than 2000 Empirical Studies

Source: (Friede et al., 2015); McKinsey analysis (Henisz et al., 2019)

More specifically, the results are 63 percent found positive ESG-CFP relationship, 8 percent found negative ESG-CFP relationship. Moreover, the significant impact of the ESG on the CFP tends to be constant over time.

Research Problem

The relationship of environment, social, and governance (ESG) with business and investment has been paid more attention to organizations and investors globally. The ESG implementation by the enterprises to increase the sustainability value would increase costs and it should impact their profitability. Some studies have found that the ESG is considered as a non-financial value of the enterprise, as it should be treated as a parallel value of the financial value. Other studies have found that the ESG effect may take a long time to play a role. Even though the ESG implementation would increase cost to firms, many studies and articles have also found the ESG factors have high percentage of positive effect on the corporate financial performance.

However, we found out that the study of the correlation between ESG performance and company's financial health and its mediating effect to other financial factors in the stock market still have been discussed rarely particularly in the case of Indonesia stock exchange. With that consideration, this journal would like to study the impact of the ESG performance on the financial health and its mediating effect to the firm value of publicly listed firms at Indonesia stock exchange.

Research Questions

To find the empirical evidence on the impact of environmental, social, and governance performance on financial health and firm value of the publicly listed firms at Indonesia Stock Exchange. Thus, the research questions are as follows:

1. Does ESG performance positively affect firm value?
2. Does ESG performance positively affect financial health?



3. Does ESG performance mediated by financial health and controlled by financial performance positively affect firm value?

LITERATURE REVIEW

ESG Performance

Environmental Social Governance (ESG) is defined as a set of activities or processes associated with an organization's relationship with its ecological surroundings, its coexistence and interaction with human organisms and other populations, and its corporate system of internal controls and procedures (such as processes, customs, policies, laws, rules, and regulations, etc.) to direct, administer and manage all the affairs of the organization, to serve the interests of stockholders and other stakeholders (Whitelock, 2015). ESG term was first coined in 2004 in a study report by the UN Global Compact in collaboration with the Swiss government entitled "Who Cares Wins" in a broad set of concepts with no standard definition. The initiative was endorsed by 23 financial institutions collectively representing more than US\$ 6 trillion in assets (Spitz et al., 2021). There are several ESG data providers, Morningstar, Bloomberg, Sustainalytics, and Morgan Stanley Capital International (MSCI). These data providers collect and evaluate the data. Up to 450 ESG data points can be collected.

Financial Performance

Financial performances are created with the use of numerical values taken from financial statements to gain meaningful information about a company. The numbers found on a company's financial statements – balance sheet, income statement, and cash flow statement – are used to perform quantitative analysis and assess a company's liquidity, leverage, growth, margins, profitability, rates of return, valuation, and more.

According to Thamrin and Sembel (2020), firms' fundamental factors have various impact to the stock return. TATO have positive and significant effect to stock return, while CR, ROA and DER have insignificant effect to stock return.

Financial Health

Altman's Z-Score model is a numerical measurement that is used to predict the chances of a business going bankrupt in the next two years. The model was developed by American finance professor Edward Altman in 1968 as a measure of the financial stability of companies. Altman's Z-score model is considered an effective method of predicting the state of financial distress of any organization by using multiple balance sheet values and corporate income. Altman's idea of developing a formula for predicting bankruptcy started at the time of the Great Depression, when businesses experienced a sharp rise in incidences of default.

Investors use Altman's Z-score to make a decision on whether to buy or sell a company's stock, depending on the assessed financial strength. If a company shows a Z-score closer to 3, investors may consider purchasing the company's stock since there is minimal risk of the business going bankrupt in the next two years. However, if a company shows a Z-score

closer to 1.8, the investors may consider selling the company's stock to avoid losing their investments since the score implies a high probability of going bankrupt.

According to Malau and Murwaningsari (2018), market pricing accrual has a significant positive effect, while a company's leverage has a significant negative effect on financial statement integrity. However, bankruptcy and foreign ownership have no significant effect on financial statement integrity.

Firm Value

The Q ratio, also known as Tobin's Q, equals the market value of a company divided by its assets' replacement cost. Thus, equilibrium is when market value equals replacement cost. At its most basic level, the Q Ratio expresses the relationship between market valuation and intrinsic value. In other words, it is a means of estimating whether a given business or market is overvalued or undervalued. The Q ratio is calculated as the market value of a company divided by the replacement value of the firm's assets. Since the replacement cost of total assets is difficult to estimate, another version of the formula is often used by analysts to estimate Tobin's Q ratio. Often, the assumption is made the market value of liabilities and the book value of a company's liabilities are equivalent, since market value typically does not account for a firm's liabilities. This provides a simplified version of the Tobin's Q ratio as equity market value divided by equity book value.

Theoretical Framework

The author illustrates the theoretical structure of this study in the diagram below:

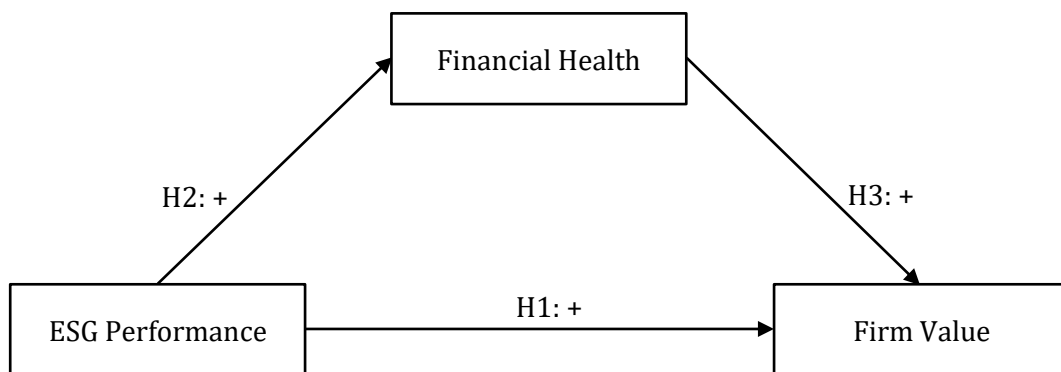

Figure-5: Impact of ESG Performance on Financial Health and Firm Value

Hypothesis Development

The author develops the hypotheses for this research according to the finding from the previous studies.

Table-1: Hypotheses of The Research

Name	Hypothesis
H1A	ENV pillar score positively affects firm value
H1B	SOC pillar score positively affects firm value



H1C	GOV pillar score positively affects firm value
H2A	ENV pillar score positively affects financial health
H2B	SOC pillar score positively affects financial health
H2C	GOV pillar score positively affects financial health
H3A	Financial health positively affect firm value
H3B	ROA positively affect firm value
H3C	TATO positively affect firm value
H3D	CR positively affect firm value
H3E	DAR positively affect firm value

RESEARCH METHODOLOGY

Research Design

A research design is plans and the procedures for research that span the decisions from broad assumptions to detailed methods of data collection and analysis (Creswell, 2014).

Table-2: Research Design

Item	Description
Method	Quantitative Approach
Collection Technique	Secondary Data
Population	Universe SRI-KEHATI ESG performance of Firms at IDX
Sampling	Selected SRI-KEHATI many sectors from S1 2019 to S2 2021
Sample Size	40 cross-section and 6 time-series total 240 observations
Data Analysis Tool	Eview 12
Model Evaluation	Panel Data Regression
Hypothesis Testing	p-value, F-statistics

Measurement of Variables

A variable is simply an attribute on which cases vary. An independent variable is understood as potentially having a causal influence on dependent variables (Bell et al., 2018).

Table-3: Research Variables

Type	Variable
Independent Variables	Environment Pillar of ESG

	Social Pillar of ESG
	Governance Pillar of ESG
Dependent Variable	Firm Value (proxied by Tobin's Q)
Mediating Variable	Financial Health (proxied by Altman Z-score)
Control Variables	Return on Asset (ROA)
	Total Asset Turn Over (TATO)
	Current Ratio (CR)
	Debt to Asset Ratio (DAR)

Variables Equations

The dependent variables of this research are the financial health which is proxied by the ALTMAN Z-Score and the firm value which is proxied by the TOBIN's Q Score. The Sobel test is basically a specialized t test that provides a method to determine whether the reduction in the effect of the independent variable.

Table-4: Variable Equations

No	Equation
1	Tobin's Q = Total Market Value of Firm / Total Asset Value of Firm
2	Altman's Z-Score = 1.2*A + 1.4*B + 3.3*C + 0.6*D + 1.0*E
3	Return on Assets (ROA) = Net Income / Total Assets
4	Total Asset Turnover (TATO) = Total Sales / Total Assets
5	Current Ratio (CR) = Current Asset / Current Liabilities
6	Debt to Asset Ratio (DAR) = Total Liabilities / Total Assets
7	Sobel (t-test) = $(a * b) / \sqrt{(b^2 * SE_a^2) + (a^2 * SE_b^2)}$

Panel Data Regression

Panel data regression is a pool time-series of cross-sections. Pooling this data gives a richer source of variation which allows for more efficient estimation of the parameters. Additionally, more informative data, one can get more reliable estimates and test more sophisticated behavioral models with less restrictive assumptions (Baltagi, 2011).

Table-5: Regression Model Equations

No	Equation
1	$TOBINSQ_{H1} = C1_{H1} + C2_{H1} * ENV + C3_{H1} * SOC + C4_{H1} * GOV + \epsilon$
2	$ALTMANZ_{H2} = C1_{H2} + C2_{H2} * ENV + C3_{H2} * SOC + C4_{H2} * GOV + \epsilon$
3	$TOBINSQ_{H3} = C1_{H3} + C2_{H3} * ALTMANZ + C3_{H3} * ROA + C4_{H3} * TATO + C5_{H3} * CR$

	$+ C6_{H3} *DAR + \varepsilon$
4	$TOBINSQ_{H4} = C1_{H4} + C2_{H4} *ENV + C3_{H4} *SOC + C4_{H4} *GOV + C5_{H4} *ALTMANZ$ $+ C6_{H4} *ROA + C7_{H4} *TATO + C8_{H4} *CR + C9_{H4} *DAR + \varepsilon$

FINDINGS, ANALYSIS, AND DISCUSSIONS

Equation 1 Regression Analysis

Table-6: Regression Result of Equation 1 TOBINSQH1

Variable	Coefficient	Std. Error	t-Statistic	Prob.
C	2.2494	0.5494	4.0942	0.0001
ENV	0.1085	0.6907	0.1571	0.8753
SOC	-0.0506	0.6365	-0.0795	0.9367
GOV	-0.3450	0.8691	-0.3970	0.6917
Root MSE	0.6389	R-squared		0.0019
Mean dependent var	0.2288	Adjusted R-squared		-0.0108
S.D. dependent var	0.6408	S.E. of regression		0.6443
Sum squared resid	97.9692	F-statistic		0.1478
Durbin-Watson stat	0.6957	Prob(F-statistic)		0.9310
R-squared	-0.0009	Mean dependent var		2.0133
Sum squared resid	1291.8150	Durbin-Watson stat		0.0528

Source: EViews 12 Analysis Output (Author, 2023)

ENV has a positive and insignificant effect on TOBINSQ. SOC has a negative and insignificant effect on TOBINSQ. GOV has a negative and insignificant effect on TOBINSQ. The regression has the probability value 0.9310 which is greater than the significance level 0.05. It means that the null hypothesis is rejected. Thus, it can be concluded that ENV, SOC and GOV have an insignificant effect on the TOBINSQ. The regression has the Adjusted R-squared value -0.0108. It means that the ENV, SOC and GOV can jointly explain the relationship with TOBINSQ only 1.08% and the remaining 98.92% explained by other variables outside the model.

Since all the individual probability (t-statistic) values are insignificant and the simultaneous probability (F-statistic) value is insignificant, the null hypothesis H0 is rejected, Thus, it can be concluded that Environment, Social and Governance pillars of ESG performance have an insignificant effect on the firm value.

Equation 2 Regression Analysis

Table-7: Regression Result of Equation 2 ALTMANZH2

Variable	Coefficient	Std. Error	t-Statistic	Prob.
C	4.5249	1.4502	3.1202	0.0020
ENV	-0.2945	1.6824	-0.1751	0.8612
SOC	0.2202	1.5479	0.1422	0.8870
GOV	0.8788	2.1168	0.4151	0.6784
Root MSE	1.5530	R-squared		0.0025
Mean dependent var	0.4974	Adjusted R-squared		-0.0102
S.D. dependent var	1.5581	S.E. of regression		1.5661
Sum squared resid	578.8040	F-statistic		0.1954
Durbin-Watson stat	1.5959	Prob(F-statistic)		0.8994
R-squared	-0.0010	Mean dependent var		5.1789
Sum squared resid	10551.3300	Durbin-Watson stat		0.0875

Source: EViews 12 Analysis Output (Author, 2023)

ENV has a negative and insignificant effect on ALTMANZ. SOC has a positive and insignificant effect on ALTMANZ. GOV has a positive and insignificant effect on ALTMANZ. The regression has the probability (F-statistic) value 0.8994 which is greater than the significance level 0.05. It means that the null hypothesis is rejected. Thus, it can be concluded that ENV, SOC and GOV have an insignificant effect on the ALTMANZ. The regression has the Adjusted R-squared value -0.0102. It means that the ENV, SOC and GOV can jointly explain the relationship with ALTMANZ only 1.02% and the remaining 98.98% explained by other variables outside the model.

Since all the individual probability (t-statistic) values are insignificant and the simultaneous probability (F-statistic) value is insignificant, the null hypothesis H₀ is rejected, Thus, it can be concluded that Environment, Social and Governance pillars of ESG performance have an insignificant effect on the financial health.

Equation 3 Regression Analysis

Table-8: Regression Result of Equation 3 TOBINSQH3

Variable	Coefficient	Std. Error	t-Statistic	Prob.
C	0.5200	0.5811	0.8948	0.3720
ALTMANZ	0.3192	0.0270	11.8111	0.0000



ROA	1.9400	2.4800	0.7823	0.4350
TATO	-0.6609	0.5440	-1.2149	0.2259
CR	-0.3906	0.0876	-4.4574	0.0000
DAR	1.7981	0.9484	1.8960	0.0594
Root MSE	0.4369	R-squared		0.9645
Mean dependent var	2.0133	Adjusted R-squared		0.9565
S.D. dependent var	2.3239	S.E. of regression		0.4847
Akaike info criterion	1.5569	Sum squared resid		45.8163
Schwarz criterion	2.2095	Log likelihood		-141.8253
Hannan-Quinn criter.	1.8198	F-statistic		120.4184
Durbin-Watson stat	1.2606	Prob(F-statistic)		0.0000

Source: EViews 12 Analysis Output (Author, 2023)

ALTMANZ has a positive and significant effect on TOBINSQ. ROA has a positive and insignificant effect on TOBINSQ. TATO has a negative and insignificant effect on TOBINSQ.

CR has a negative and significant effect on TOBINSQ. DAR has a positive and insignificant effect on TOBINSQ. The regression has the probability (F-statistic) value 0.0000 which is smaller than the significance level 0.05. It means that the null hypothesis is accepted. It can be concluded that ALTMANZ, ROA, TATO, CR and DAR jointly have a significant effect on the TOBINSQ. The Adjusted R-squared value 0.9565. It means that the ALTMANZ, ROA, TATO, CR and DAR jointly explain the relationship with TOBINSQ up to 95.65%.

Since some of the individual probability (t-statistic) values are significant and some other are insignificant and the simultaneous probability (F-statistic) value is significant, the null hypothesis H₀ is partially accepted, Thus, it can be concluded that Return on Asset, Total Asset Turnover and Debt to Asset Ratio have an insignificant effect on the firm value, while financial health and Current Ratio have a significant effect on the firm value.

Equation 4 Regression Analysis

Table-9: Regression Result of Equation 4 TOBINSQH4

Variable	Coefficient	Std. Error	t-Statistic	Prob.
C	0.7806	0.6604	1.1820	0.2387
ENV	0.4328	0.5289	0.8182	0.4142
SOC	-0.0061	0.4934	-0.0123	0.9902
GOV	-0.8689	0.6818	-1.2744	0.2041

**Accounting Inquiries with New Approaches in the Post-Pandemic Era
Volume I**

ALTMANZ	0.3195	0.0273	11.7182	0.0000
ROA	2.2629	2.5158	0.8995	0.3695
TATO	-0.5866	0.5485	-1.0695	0.2862
CR	-0.3799	0.0889	-4.2736	0.0000
DAR	1.9817	0.9984	1.9849	0.0486
Root MSE	0.4348	R-squared		0.9648
Mean dependent var	2.0133	Adjusted R-squared		0.9562
S.D. dependent var	2.3239	S.E. of regression		0.4861
Akaike info criterion	1.5721	Sum squared resid		45.3727
Schwarz criterion	2.2683	Log likelihood		-140.6579
Hannan-Quinn criter.	1.8526	F-statistic		112.1227
Durbin-Watson stat	1.2398	Prob(F-statistic)		0.0000

Source: EViews 12 Analysis Output (Author, 2023)

ENV has a positive and insignificant effect on TOBINSQ. SOC has a negative and insignificant effect on TOBINSQ. GOV has a negative and insignificant effect on TOBINSQ. ALTMANZ has a positive and significant effect on TOBINSQ. ROA has a positive and insignificant effect on TOBINSQ. TATO has a negative and insignificant effect on TOBINSQ. CR has a negative and significant effect on TOBINSQ. DAR has a positive and significant effect on TOBINSQ. The regression has the probability (F-statistic) value 0.0000 which is smaller than the significance level 0.05. It means that the null hypothesis is accepted. Thus, it can be concluded that ENV, SOC and GOV have a significant effect on the TOBINSQ. The regression has the Adjusted R-squared value 0.9562. It means that the ENV, SOC, GOV, ALTMANZ, ROA, TATO, CR and DAR can jointly explain the relationship with TOBINSQ up to 95.62% and only the remaining 4.38% explained by other variables outside the research model.

Since some of the individual probability (t-statistic) values are significant and some other are insignificant and the simultaneous probability (F-statistic) value is significant, the null hypothesis H₀ is partially accepted, Thus, it can be concluded that Environment, Social and Governance pillars of ESG performance, Return on Asset, and Total Asset Turnover have an insignificant effect on the firm value, while financial health, Current Ratio and Debt to Asset Ratio have a significant effect on the firm value.

Mediating Variable Test

Table-10: Sobel Test of Mediating Variable

Dependent Variable: ALTMANZ				
	Coefficient	Std. Error	z (p=0.05)	z-value
ENV	-0.2945	1.6824	1.9701	-0.1750
SOC	0.2202	1.5479	1.9701	0.1422



GOV	0.8788	2.1168	1.9701	0.4149
Dependent Variable: TOBINSQ				
	Coefficient	Std. Error		
ALTMANZ	0.3195	0.0273		

The ALTMANZ intervening variable for ENV independent variable has z-value -0.1750, while for critical p-value 0.05 it has z-value 1.9701. It means that the null hypothesis is rejected. Thus, it can be concluded that ALTMANZ has a negative and insignificant effect as intervening variable for ENV independent variable.

The ALTMANZ intervening variable for SOC independent variable has z-value 0.1422, while for critical p-value 0.05 it has z-value 1.9701. It means that the null hypothesis is rejected. Thus, it can be concluded that ALTMANZ has a positive and insignificant effect as intervening variable for SOC independent variable.

The ALTMANZ intervening variable for ENV independent variable has z-value 0.4149, while for critical p-value 0.05 it has z-value 1.9701. It means that the null hypothesis is rejected. Thus, it can be concluded that ALTMANZ has a positive and insignificant effect as intervening variable for SOC independent variable.

Summary of Panel Data Regression

Table-11: Regression Summary

Dependent Variable: TOBINSQ										
Equation	ENV	SOC	GOV	p	H0					
1	+	-	-	n	r					
Dependent Variable: ALTMANZ										
Equation	ENV	SOC	GOV	p	H0					
2	-	+	+	n	r					
Dependent Variable: TOBINSQ										
Equation	ALTMANZ	ROA	TATO	CR	DAR	p	H0			
3	+***	+	-	-***	+	s***	f			
Dependent Variable: TOBINSQ										
Equation	ENV	SOC	GOV	ALTMANZ	ROA	TATO	CR	DAR	p	H0
4	+	-	-	+***	+	-	-***	+	s***	f
Description: Significant levels at *** p < 0.01, ** p < 0.05, * p < 0.10, p = p-value, s = significant, n = not significant, H0 = null hypothesis, f = fail to reject, r = reject										

Equation 1 TOBINSQH1 panel data regression has ENV independent variable with positive coefficient and p-value insignificant, SOC independent variable with negative coefficient and p-value insignificant, and SOC independent variable with negative

coefficient and p-value insignificant. Equation 1 has simultaneous p-value insignificant and null hypothesis is rejected.

Equation 2 ALTMANZH2 panel data regression has ENV independent variable with negative coefficient and p-value insignificant, SOC independent variable with positive coefficient and p-value insignificant, and SOC independent variable with positive coefficient and p-value insignificant. Equation 2 has simultaneous p-value insignificant and null hypothesis is rejected.

Equation 3 TOBINSQH3 panel data regression has has ALTMANZ independent variable with positive coefficient and p-value significant at level 0.01, ROA control variable with positive coefficient and p-value insignificant, TATO control variable with negative coefficient and p-value insignificant, CR control variable with negative coefficient and p-value significant at level 0.01 and DAR control variable positive coefficient and p-value insignificant. Equation 3 has simultaneous p-value significant at level 0.01 and null hypothesis is fail to be rejected.

Equation 4 TOBINSQH4 panel data regression has ENV independent variable with positive coefficient and p-value insignificant, SOC independent variable with negative coefficient and p-value insignificant, and SOC independent variable with negative coefficient and p-value insignificant. Equation 4 has ALTMANZ mediating variable with positive coefficient and p-value significant at level 0.01, ROA control variable with positive coefficient and p-value insignificant, TATO control variable with negative coefficient and p-value insignificant, CR control variable with negative coefficient and p-value significant at level 0.01 and DAR control variable positive coefficient and p-value significant at level 0.05. Equation 4 has simultaneous p-value significant at level 0.01 and null hypothesis is fail to be rejected.

CONCLUSIONS AND RECOMMENDATIONS

Conclusions

From the panel data regression finding and analysis, the author concludes that the ESG performance which represent by Environment, Social and Governance pillar scores do not have significant effect directly to the firm value. The ESG performance also do not have significant effect to the financial health.

Furthermore, The ESG performance do not have significant effect when mediated by financial health as intervening factor to the firm value. The financial health itself has significant effect to the firm value. Several control variables of the financial performance which are ROA and TATO do not have significant effect to the firm value. Meanwhile several other control variables of the financial performance which are CR and DAR have significant effect.

Recommendations

Based on the data analysis, the author found that there are different characteristics of the ESG performance, financial health, financial performance and firm value which are determined by the sector and profitability of the firms. The ESG performance score also have small variance and high correlation among the pillars. The firms on the list of ESG performance also keep changing for each period. The recommendations for further research are as follow:



1. To study the impact of ESG performance to financial health and firm value according to the sectors.
2. To study the impact of ESG performance to the profitability of the firm.
3. To study the ESG performance scoring criteria and method improvement.

REFERENCES

- Albuquerque, R. A., Durnev, A., & Koskinen, Y. (2014). Corporate social responsibility and firm risk: Theory and empirical evidence. CEPR Discussion Paper No. 9533.
- Almeyda, R., & Darmansya, A. (2019). The influence of environmental, social, and governance (ESG) disclosure on firm financial performance. *IPTEK Journal of Proceedings Series*, (5), 278-290.
- Altman, E. I. (1968). Financial ratios, discriminant analysis and the prediction of corporate bankruptcy. *Journal of Finance*, 23(4), 589–609.
- Anderson, D. R., Sweeney, D. J., & Williams, T. A. (2011). *Statistics for Business and Economics*. South-Western Pub.
- Aslan, A., Poppe, L., & Posch, P. N. (2021). Are Sustainable Companies More Likely to Default? Evidence from the Dynamics between Credit and ESG Ratings. *Sustainability*, 13(15), 8568. <https://doi.org/10.3390/su13158568>
- Atan, R., Alam, M. M., Said, J., and Zamri, M. (2018). The impacts of environmental, social, and governance factors on firm performance: Panel study of Malaysian companies. *Management of Environmental Quality*, Vol. 29 No. 2, 182-194. <https://doi.org/10.1108/MEQ-03-2017-0033>
- Attig, N., El Ghouli, S., & Guedhami, O. (2013). Corporate social responsibility and credit ratings. *Journal of Business Ethics*, 117(4), 679-694. <https://doi.org/10.1007/s10551-013-1714-2>
- Baltagi, B. H. (2005). *Econometric Analysis of Panel Data*. John Wiley & Sons.
- Bell, E., Bryman, A., & Harley, B. (2018). *Business Research Methods*. Oxford University Press.
- Birindelli, G., Ferretti, P., Intonti, M., & Iannuzzi, A. P. (2015). On the drivers of corporate social responsibility in banks: Evidence from an ethical rating model. *Journal of Management and Governance*, 19, 303-340. <https://doi.org/10.1007/s10997-013-9262-9>
- Blumenshine, N. T., & Wunnava, P. V. (2010). The value of green: The effect of environmental rankings on market cap. *Technology and Investment*, 01(04), 239–242. <https://doi.org/10.4236/ti.2010.14030>
- Boffo, R., & Patalano, R. (2020). ESG investing: Practices, progress and challenges. OECD Paris, <https://www.oecd.org/finance/ESG-Investing-Practices-Progress-and-Challenges.pdf>
- Bradley, B. (2021). *ESG investing for dummies*. John Wiley & Sons.
- Damodaran, A. (2012). *Investment valuation: Tools and techniques for determining the value of any asset*. John Wiley & Sons.
- Devalle, A., Fiandrino, S., & Cantino, V. (2017). The linkage between ESG performance and credit ratings: A firm-level perspective analysis. *International Journal of Business and Management*, 12(9), 53. <https://doi.org/10.5539/ijbm.v12n9p53>
- Dieschbourg, M. T. & Nussbaum A. P. (2017). Environmental, social, and governance investing: No place to hide thanks to morningstar, bloomberg, MSCI, and multiple global data providers. *Journal of Investment Consulting*. Investments & Wealth Institute.
- Ditlev-Simonsen, C. D. (2021). *A guide to sustainable corporate responsibility: From theory to action*. Palgrave Macmillan.
- Eccles, R. G., Ioannou, I., & Serafeim, G. (2014). The Impact of Corporate Sustainability on Organizational Processes and Performance. *Management Science*, 60(11), 2835–2857. <http://www.jstor.org/stable/24550546>
- Enhance our global footprint. (n.d.). PRI. <https://www.unpri.org/annual-report-2020/how-we-work/building-our-effectiveness/enhance-our-global-footprint>
- Fatemi, A., Glaum, M., & Kaiser, S. (2018). ESG performance and firm value: The moderating role of disclosure. *Global Finance Journal*, 38, 45–64. <https://doi.org/10.1016/j.gfj.2017.03.001>
- Friede, G., Busch, T., & Bassen, A. (2015). ESG and financial performance: aggregated evidence from more than 2000 empirical studies. *Journal of Sustainable Finance & Investment*, 5(4), 210–233. <https://doi.org/10.1080/20430795.2015.1118917>
- Habermann, F., & Fischer, F. R. (2021). Corporate social performance and the likelihood of bankruptcy: Evidence from a period of economic upswing. *Journal of Business Ethics*, 182(1), 243–259. <https://doi.org/10.1007/s10551-021-04956-4>

Accounting Inquiries with New Approaches in the Post-Pandemic Era
Volume I

- Haffar, M. (2017). Classification of trade-offs encountered in the practice of corporate sustainability. *Journal of Business Ethics*, 140(3), 495–522. <https://doi.org/10.1007/s10551-015-2678-1>
- Harymawan, I., Putra, F. K. K., Fianto, B. A., & Ismail, W. A. W. (2021). Financially distressed firms: Environmental, social, and governance reporting in Indonesia. *Sustainability*, 13(18), 10156. <https://doi.org/10.3390/su131810156>
- Henisz, W., Koller, T., & Nuttall, R. (2019). Five ways that ESG creates value. *McKinsey Quarterly*, November, 1–12. <https://www.mckinsey.com/business-functions/strategy-and-corporate-finance/our-insights/five-ways-that-esg-creates-value>
- Hill, J. (2020). *Environmental, social, and governance (ESG) investing: A balanced analysis of the theory and practice of a sustainable portfolio*. Academic Press.
- Hsiao, C., Jiang, Q., Lian, L., & Wang, Y. (2022). The impact of environment, social, and governance (ESG) performance on the change of z-score before and after the COVID-19: The case of chinese a-share manufacturing industry companies. *Asian Journal of Economics, Business and Accounting*, 46–57. <https://doi.org/10.9734/ajeba/2022/v22i630571>
- Juetten, M. (2014). Pay attention to innovation and intangibles: They're more than 80% of your business' value. *Forbes*. <https://www.forbes.com/sites/maryjuetten/2014/10/02/pay-attention-to-innovation-and-intangibles-more-than-80-of-your-business-value/?sh=12c143b11a67>
- Junius, D., Adisurjo, A., Rijanto, Y. A., & Adelina, Y. E. (2020). The impact of ESG performance to firm performance and market value. *Jurnal Aplikasi Akuntansi*, 5(1), 21-41.
- Khan, M., Serafeim, G., & Yoon, A. (2016). Corporate sustainability: First evidence on materiality. *The Accounting Review*, 91(6), 1697–1724. <https://doi.org/10.2308/accr-51383>
- Lang, L., & Stulz, R. (1994). Tobin's Q, diversification, and firm performance. *Journal of Political Economy*, 102, 1248–1280.
- Lawton, G. (2023). A timeline and history of ESG investing, rules and practices. *Sustainability and ESG*. <https://www.techtarget.com/sustainability/feature/A-timeline-and-history-of-ESG-investing-rules-and-practices>
- Lee, D. D., & Faff, R. W. (2009). Corporate sustainability performance and idiosyncratic risk: A global perspective. *The Financial Review*, 44, 213-237.
- Lisin, A., Kushnir, A., Koryakov, A. I., Fomenko, N. M., & Shchukina, T. (2022). Financial stability in companies with high ESG scores: Evidence from north america using the ohlson o-score. *Sustainability*, 14(1), 479. <https://doi.org/10.3390/su14010479>
- Malau, M., & Murwaningsari, E. (2018). The effect of market pricing accrual, foreign ownership, financial distress, and leverage on the integrity of financial statements. *Ekonomski Anali*, 63(217), 129–139. <https://doi.org/10.2298/eka1817129m>
- Mayor, T. (2019). Why ESG ratings vary so widely (and what you can do about it). *MIT Thinking Forward Newsletter*. <https://mitsloan.mit.edu/ideas-made-to-matter/why-esg-ratings-vary-so-widely-and-what-you-can-do-about-it>
- Morningstar. (2021). Global sustainable fund flows: Q1 2021 in review - ESG fund assets climb to shy of USD 2 trillion boosted by record inflows. 1–23. https://www.morningstar.com/content/dam/marketing/emea/uk/Europe_ESG_Q1_2021_Flow_final.pdf
- Berger, P., & Ofek, E. (1994). Diversification's effect on firm value. *Journal of Financial Economics*, 37, 39–65.
- Schmidlin, N. (2014). *The art of company valuation and financial statement analysis: A value investor's guide with real-life case studies*. John Wiley & Sons.
- Sekaran, U., & Bougie, R. (2016). *Research methods for business: A skill building approach*. John Wiley & Sons.
- Sherwood, M. W., & Pollard, J. (2018). *Responsible investing: An introduction to environmental, social, and governance investments*. Routledge.
- Spitz, K., Trudinger, J., & Orr, M. (2021). *Environmental social governance: Managing risk and expectations*. CRC Press.
- Thamrin, J., & Sembel, R. (2020). The effect of company's fundamental, market return and macroeconomic to stock return: A case study of consumer goods companies listed in BEI period 2009-2018. *International Journal of Business Studies*. <https://doi.org/10.32924/ijbs.v4i3.115>
- Tobin, J. (1969). A general equilibrium approach to monetary theory. *Journal of Money, Credit & Banking*, 1, 15-29. <https://doi.org/10.2307/1991374>
- Wahlen, J. M., Baginski, S. P., & Bradshaw, M. (2014). *Financial reporting, financial statement analysis and valuation*. Cengage Learning.
- Whitelock, V. G. (2015). Environmental social governance management: A theoretical perspective for the role of disclosure in the supply chain. *International Journal of Business Information Systems*, 18(4), 390-405. <https://ideas.repec.org/a/ids/ijbis/v18y2015i4p390-405.html>



- Wooldridge, J. M. (2010). *Econometric analysis of cross section and panel data*, second edition. MIT Press.
- Yoon, B., Lee, J. H., & Byun, R. (2018). Does ESG performance enhance firm value? Evidence from Korea. *Sustainability (Switzerland)*, 10(10). <https://doi.org/10.3390/su10103635>
- Yu, E. P., Guo, C. Q., & Luu, B. V. (2018). Environmental, social and governance transparency and firm value. *Business Strategy and the Environment*, 27(7), 987-1004. <https://doi.org/10.1002/bse.2047>
- Zeidan, R., Boechat, C., & Fleury, A. (2015). Developing a sustainability credit score system. *Journal of Business Ethics*, 127(2), 283-296. <https://doi.org/10.1007/s10551-013-2034-2>

CHAPTER 15

The Effect of Tax Avoidance and Capital Structure on Firm Value (Empirical Study of Financial Companies Listed on The IDX For the 2017 – 2021 Period)

Ruly Rakasiwi

Accounting, Faculty of Economics and Business
Bhayangkara University Jakarta Raya Jakarta Indonesia
ruly.rakasiwi18@mhs.ubharajaya.ac.id

Amor Marundha

Accounting, Faculty of Economics and Business
Bhayangkara University Jakarta Raya Jakarta Indonesia
amor.marundha@dsn.ubharajaya.ac.id
Orcid: 0000-0001-9861-8420

Uswatun Khasanah

Accounting, Faculty of Economics and Business
Bhayangkara University Jakarta Raya Jakarta Indonesia
uswatun.khasanah@dsn.ubharajaya.ac.id
Orcid: 0000-0002-2278-5094

ABSTRACT

The purpose of this study is to estimate and partially examine the effect of tax avoidance and capital structure on firm value. The type of research used is quantitative research. The population of this study is financial companies listed on the Indonesia Stock Exchange during 2017 – 2020, a total of 43 samples with 215 observations obtained through purposive sampling technique. The data analysis method used is panel data regression analysis with the help of Eviews version 12. The results of this study indicate that tax avoidance has a positive but not significant effect on firm value. Capital structure has a negative and significant effect on firm value. The limitations of this study are that there is the possibility of human error during data tabulation and there is also the possibility of using inappropriate formulas.

Keywords: Tax Avoidance, Capital Structure, Firm Values.



INTRODUCTION

The state's largest source of funding is taxes. Based on the current State Revenue and Expenditure Budget, tax revenues have not met the target. This is because there are differences in the interests of the government and taxpayers. Therefore the government continues to strive to optimize tax revenue, compared to companies as corporate taxpayers who seek to minimize corporate tax payments.

This effort is made by the company because tax is a burden that can reduce profits, while the goal of the company is to get maximum profit. The high profit of the company can reflect the prosperity of the shareholders as well as a benchmark for how management's performance increases the value of the company. The value of the company is very important because it can affect the views of investors to invest their capital.

Various attempts were made to increase the value of the company, such as by implementing tax avoidance schemes and also adjusting the proportion of the capital structure. To maximize profit, it is not uncommon for companies to choose to optimize debt as a source of funding. Because, interest expense from debt can be a deduction from taxable income.

Firm value can be defined as investors' understanding of the success of an industry related to the capitalization value of stock prices and profits used to show how much economic size can show the value of shares in the capital market. Tax avoidance is an effort made to legally save and minimize taxes through tax management. The comparison between total debt and total equity is a way of finding a company's capital structure, which can be defined as the method used by a company to pay off debt in order to increase the value of the company so that investors can indicate the level of risk, taking, and company income.

With the existence of tax planning activities, a small tax burden can increase profits after tax so that the value of the company increases. Companies that implement tax avoidance reduce the information contained in their financial reports which is the main trigger for the decline in company value. The greater the tax that must be paid, the less profit to be obtained. Financial companies are companies that are expected to have good opportunities in the future, because the daily activities of Indonesian people are inseparable from finance. Financial companies have a fairly large role in state revenues. Previous empirical studies have examined the effect of tax avoidance and capital structure on firm value. However, research on the effect of tax avoidance and capital structure on firm value has not been widely tested, especially in Indonesia. So, researchers are interested in examining the effect of tax avoidance and capital structure on firm value.

Based on the description above, the authors conducted a study entitled "THE EFFECT OF TAX AVOIDANCE AND CAPITAL STRUCTURE ON COMPANY VALUE (EMPIRICAL STUDY OF FINANCIAL COMPANIES LISTED ON THE INDONESIA STOCK EXCHANGE FOR THE 2017 - 2021 PERIOD)".

Formulation of the problem

Based on the background of the problems described above, the formulation of the problem that can be used as the basis for the study in the research to be carried out is as follows.

1. Does tax avoidance partially affect firm value?
2. Does the capital structure partially affect the firm value?

Research purposes

Based on the formulation of the problem above, the objectives to be achieved through this research process are as follows.

1. To estimate and test the effect of tax avoidance on firm value.
2. To estimate and test the effect of capital structure on firm value.

1. LITERATURE REVIEW

1.1. Agency Theory

Agency theory is a theory put forward by Jensen and Meckling (1976) explains that agency theory describes a contractual bond between the party giving the trust (shareholders) as the principal and the party given the trust (management) as the agent. Devi and Arinta (2021) explains that the purpose of agency theory is to improve the ability of individuals (shareholders and management) when improving the environment to make decisions.

1.2. Trade Off Theory

The theory introduced by Modigliani and Miller (1963) explained that a company if it does not use debt as a capital structure is a bad company. Sadewo et al. (2017), Sartono and Ratnawati (2020), Fauziah and Sudiyatno (2020), and Megawati et al. (2021) explained that the use of debt is at an ideal point if the costs of using debt are commensurate with the benefits of using debt obtained when in debt.

1.3. Signaling Theory

The theory introduced by Spence (1973) later developed by Ross (1977) said that when company management provides certain information about the company that must be conveyed to other parties outside the company, they will send certain signals which can be in the form of company performance, profit or loss reports, expenses or costs incurred by the company, and also the company's financial condition.

1.4. Tax Avoidance

Tax Avoidance is the manipulation of tax matters that are still within the framework of tax provisions (Princess and Hudiwinarsih, 2018). Asa and Utomo, (2019) explained that tax avoidance is a practice carried out by companies that shows the transfer of wealth from the government to companies and will increase the value of the company.

1.5. Capital Structure

Irawan and Kusuma (2019) as well as Setiawan et al. (2021) revealed that the capital structure is a combination of debt and equity in the long-term financial structure of the company, whether or not the company's capital structure has an impact on company value.

1.6. The value of the company

Suzulia et al. (2020) explains that the value of the company is the market value or the price that applies to the company's common shares. The understanding of investors, creditors,



stakeholders regarding the condition of the company is through the stock market which is useful for measuring the value of the company (Irawan and Kusuma, 2019).

2. Hypothesis Development

2.1. Tax Avoidance Partially Against Company Value

tax avoidance is an effort to legally save and minimize taxes through tax management. The practice of tax avoidance as a form of tax management is a strategy in minimizing tax payments that are still within the limits of statutory provisions. By doing this tax avoidance the company can minimize the burden paid thereby increasing the company's profit, where if the company's profit increases it is expected to be a positive signal for investors thereby increasing the value of the company.

Research conducted by Eskandarlee and Sadri (2017), Apsari and Setiawan (2018), Putri and Hudiwinarsih (2018), Nugraha and Setiawan (2019), Kartika et al. (2019), Oktaviani et al. (2019), Mappadang (2019), Nurfadilah and Rosharlianti (2020), Arfiansyah (2020), Zulfiara and Ismanto (2020), as well as Radina et al. (2021) explains that tax avoidance has a positive and significant effect on firm value. These results explain that the higher the tax avoidance by the company will increase the value of the company. Based on this description, the hypothesis can be formulated as follows:

H1: Tax avoidance partially affects firm value.

2.2. The Effect of Partial Capital Structure on Firm Value

Capital structure is the result of funding decisions to determine whether to use debt or equity to finance company activities (Yanti and Darmayanti, 2019). Sadewo et al. (2017) explained that the use of debt is at an ideal point if the costs of using debt are commensurate with the benefits of using debt obtained when in debt.

Research that has been conducted by Aggarwal and Padhan (2017), Hidayat (2018), Israel et al. (2018), Uzliawati et al. (2018), Mujijah et al. (2019), Ramdhonah et al. (2019), Suzulia et al. (2020), Syamsudin et al. (2020), Nurazi et al. (2020), Revi and Anom (2021), as well as Setiawan et al. (2021) explains that capital structure has a positive and significant effect on firm value. The research results show that any increase in a company's capital structure as measured by the debt to equity ratio can increase the value of a company. The company's capital structure is permanent financing consisting of long-term debt, preferred stock and shareholder's capital. Thus, the capital structure of a company is only a part of its financial structure. Based on this description, the hypothesis can be formulated as follows:

H2: Capital structure partially affects firm value.

3. RESEARCH METHODS

This type of research used is quantitative research. The population of this study are financial companies listed on the Indonesia Stock Exchange during 2017 - 2020, totaling 43 samples with 215 observations obtained through a purposive sampling technique. The data analysis method used is panel data regression analysis with the help of Eviews version 12. The details of obtaining the research sample are as follows.

**Table 3.1
Details of Obtaining Research Samples**

Criteria	Total
Financial company listed on the Indonesia Stock Exchange during 2017 – 2021.	138
Annual financial reports that can be accessed by researchers in full from 2017 – 2021 in rupiah currency units.	121
Companies that earn profits in the financial statements during the year of observation.	76
Companies that issue shares during the period 2017 – 2021.	43
Number of samples	43
Number of observations (43 x 5 years)	215

Source: Data Processing Results (2022)

3.1. Variable Operationalization

Operationalization of variables is an explanation given to the variables studied and then given meaning, so that the variables studied are in accordance with the scope of activity of operational variables (Rukajat, 2018:2). In order to avoid ambiguity in the meaning of the variables used, the following is an operational explanation of these variables.

3.3. Dependent Variable

The dependent variable in this study is firm value. In measuring the value of the company is using Tobin's Q theory developed by (Tobin 1969) by comparing the ratio of the market value of the company's shares to the book value of the company's equity. The core of this theory is the way monetary policy affects the economy through its effect on equity valuation. Firm value calculated using Tobin's Q uses the formula:

$$\text{Tobin's } Q = \frac{\text{Market Capitalization} + \text{Total Debt}}{\text{Total Assets}}$$

Market Capitalization = closing share price multiplied by the number of outstanding shares.

3.4. Independent Variable

Tax Avoidance

Maulana et al. (2021) explained that the Effective Tax Rate (ETR) is used as a reference for measurement because it can consider the difference between book profit and tax profit. The Effective Tax Rate (ETR) can be calculated using a ratio scale by dividing the current income tax expense by pre-tax profit. If the ratio scale shows a percentage of 25%



down to close to zero then it indicates the presence of Tax Avoidance. Calculation of the Effective Tax Rate (ETR) can be done using the following formula:

$$\text{ETR} = \frac{\text{Current Tax}}{\text{Profit Before Tax}}$$

Capital Structure

Nursolehudin et al. (2019) explained that the capital structure can be calculated using the Debt to Equity Ratio (DER) ratio which is used to measure the amount of capital provided by creditors and to measure how much influence the company's debt has on equity. If the results of the DER ratio are high, it shows that the company's capital is used less compared to the use of debt. Calculation of the Debt to Equity Ratio (DER) can be done using the formula:

$$\text{DER} = \frac{\text{Total Debt}}{\text{Total Equitas}}$$

Panel Data Regression Estimation Model

The panel data regression model in this study can be formulated as:

$$Y = \alpha + \beta_1 X_{1it} + \beta_2 X_{2it} + \varepsilon$$

Information:

- Y = dependent variable
- α = Constant (intercept)
- X1 = Independent variable
- X2 = Independent variable
- β_1 = Coefficient (slope)
- β_2 = Coefficient (slope)
- ε = error component
- i = Time
- t = Company

4. RESULTS AND DISCUSSION

4.1. Results of Descriptive Statistical Analysis

Descriptive statistical test is used to describe a data statistically using Eviews 12. The results of data processing in the form of descriptive statistics will display the characteristics of the sample used in this study including: minimum value, maximum value, average value (mean), and standard deviation for each variable. The description in this study includes 3 variables, namely, tax avoidance, capital structure and firm value. Based on the results of data processing using Eviews 12, the results of the descriptive statistical test of the research data can be seen in table 4.1 below:

Table 4.1 Descriptive Statistical Test Results

	X1	X2	Y
Mean	0.236349	3.845912	1.122944
Median	0.238000	3.310000	0.983000
Maximum	0.971000	16.07900	5.094000
Minimum	0.001000	0.003000	0.167000
Std. Dev.	0.117466	2.915922	0.539492
Skewness	2.012349	1.164575	4.085237
Kurtosis	14.27223	4.899116	26.80939
Jarque-Bera	1283.383	80.90791	5676.391
Probability	0.000000	0.000000	0.000000
Sum	50.81500	826.8710	241.4330
Sum Sq. Dev.	2.952833	1819.556	62.28507
Observations	215	215	215

Source: Results of data processing with Eviews 12

From table 4.1 above, it can be seen that the tax avoidance variable (X1) which is proxied by the Effective Tax Rate (ETR) has a maximum value of 0.971000 and a minimum value of 0.001000. These results indicate that the value of tax avoidance ranges from 0.971000 to 0.001000, where the largest tax avoidance value is owned by PT. Buana Artha Anugerah Tbk. in 2018, while the smallest tax avoidance value is owned by PT. Panin Financial Tbk. in 2018, 2019 and 2020. Meanwhile, the average value (mean) obtained was 0.236349. These results indicate that the magnitude of the average value (mean) obtained ranges from 0% to 23.6%. The standard deviation value obtained is 0.117466 which has a lower value than the mean (mean).

The capital structure variable (X2) which is proxied by the Debt to Equity Ratio (DER) has a maximum value of 16.07900 and a minimum value of 0.003000. These results indicate that the value of tax avoidance ranges from 16.07900 to 0.003000, where the largest capital structure value is owned by PT. State Savings Bank (Persero) Tbk. in 2020, while the smallest capital structure value is owned by PT. Buana Artha Anugerah Tbk. in 2020. Meanwhile, the average value (mean) obtained was 3.845912. These results indicate that the magnitude of the average value (mean) obtained ranges from 0% to 384.5%. The standard deviation value obtained is 2.915922 which has a lower value than the average value (mean).

The variable (Y) of firm value proxied by Tobins'Q has a maximum value of 5.094000 and a minimum value of 0.167000. These results indicate that the value of the company ranges from 5.094000 to 0.167000, where the largest capital structure value is owned by PT. Batavia Prosperindo Internasional Tbk. in 2018, while the smallest capital structure value is owned by PT. Adira Dinamika Multi Finance Tbk. in 2018. Meanwhile, the average value (mean) obtained was 1.122944. These results indicate that the magnitude of the average value (mean) obtained ranges from 0% to 112.2%. The standard deviation value obtained is 0.539492 which has a lower value than the average value (mean).

4.2. Panel Data Regression Estimation Test Results

Basuki and Prawoto (2017:278-280) explained that there are three panel data regression estimation methods, namely the Common Effect Model, Fixed Effect Model and Random Effect Model to select the panel data model collected, can be seen in the following table:



Table 4.2 Common Effect Model Panel Data Regression Results

Variable	Coefficient	Std. Error	t-Statistic	Prob.
C	0.230811	0.062556	3.689654	0.0003
X1	0.092214	0.027247	3.384406	0.0008
X2	-0.038279	0.022685	-1.687443	0.0930
R-squared	0.051325	Mean dependent var		0.046512
Adjusted R-squared	0.042376	S.D. dependent var		0.395860
S.E. of regression	0.387382	Akaike info criterion		0.955043
Sum squared resid	31.81369	Schwarz criterion		1.002075
Log likelihood	-99.66709	Hannan-Quinn criter.		0.974046
F-statistic	5.734842	Durbin-Watson stat		0.834108
Prob(F-statistic)	0.003753			

Source: Results of data processing with Eviews 12

Table 4.3 Fixed Effect Model Panel Data Regression Results

Variable	Coefficient	Std. Error	t-Statistic	Prob.
C	0.132531	0.074956	1.768125	0.0788
X1	0.003177	0.030002	0.105900	0.9158
X2	-0.090532	0.038811	-2.332619	0.0208
Effects Specification				
Cross-section fixed (dummy variables)				
R-squared	0.667826	Mean dependent var		0.046512
Adjusted R-squared	0.581852	S.D. dependent var		0.395860
S.E. of regression	0.255980	Akaike info criterion		0.296332
Sum squared resid	11.13940	Schwarz criterion		1.001815
Log likelihood	13.14429	Hannan-Quinn criter.		0.581380
F-statistic	7.767743	Durbin-Watson stat		2.234955
Prob(F-statistic)	0.000000			

Source: Results of data processing with Eviews 12

Table 4.4 Regression Results of Panel Data Random Effect Model

Variable	Coefficient	Std. Error	t-Statistic	Prob.
C	0.136436	0.075946	1.796472	0.0738
X1	0.023886	0.026561	0.899303	0.3695
X2	-0.057154	0.028786	-1.985501	0.0484
Effects Specification				
			S.D.	Rho
Cross-section random			0.283036	0.5501
Idiosyncratic random			0.255980	0.4499
Weighted Statistics				
R-squared	0.017610	Mean dependent var		0.017440
Adjusted R-squared	0.008342	S.D. dependent var		0.261947
S.E. of regression	0.260852	Sum squared resid		14.42528
F-statistic	1.900143	Durbin-Watson stat		1.745843
Prob(F-statistic)	0.152085			
Unweighted Statistics				
R-squared	0.000298	Mean dependent var		0.046512
Sum squared resid	33.52487	Durbin-Watson stat		0.751211

Source: Results of data processing with Eviews 12

4.3. Model Selection Test Results

Basuki and Prawoto (2017:277) explains to choose the most appropriate model to use in managing panel data, includes several tests as follows:

1. Chow test

Is a test to determine the most appropriate fixed effect or common effect model used in estimating panel data. Determination of the model is done by statistical test F or chi-square with the hypothesis:

H₀ = The common effect model is better than the fixed effect model.

H₁ = The fixed effect model is better than the common effect model.

- If the probability value of the F test or chi-square > 0.05, then H₀ is accepted so that the common effect model is used.
- If the probability value of the F test or chi-square < 0.05, then H₀ is rejected, so the fixed effect model is used.

The results of the chow test with Eviews 12 from the research data can be seen in table 4.6 as follows:

Table 4.5 Chow Test Results

Effects Test	Statistic	d.f.	Prob.
Cross-section F	7.512221	(42,170)	0.0000
Cross-section Chi-square	225.622771	42	0.0000

Source: Results of data processing with Eviews 12

The results of the chow test in table 4.5 show that the probability value of the chi-square cross-section is 0.0000. The probability value of the chi-square cross-section < 0.05, then H₀ is rejected. Therefore the selected model is the fixed effect model, it is necessary to do the Hausman test.

2. Hausman test

Is a statistical test to choose whether the fixed effect or random effect model is the most appropriate to use. The hypothesis used in the Hausman test is as follows:

H₀ = The random effect model is better than the fixed effect.

H₁ = Fixed effect model is better than random effect.

- If the p-value > 0.05, then H₀ is accepted so that the random effect model is used.
- If the p-value < 0.05, then H₀ is rejected, thus the fixed effect model is used.

The results of the Hausman test with Eviews 12 from this research data can be seen in table 4.5 as follows:

Table 4.6 Hausman Test Results

Test Summary	Chi-Sq. Statistic	Chi-Sq. d.f.	Prob.
Cross-section random	10.146225	2	0.0063

Source: Results of data processing with Eviews 12



The test results in table 4.6 can be seen that the random cross section probability value is 0.0063. The random cross section probability value is <0.05 , which means that the fixed effect model is more appropriate. Because at this stage the selected effect model is the fixed effect, there is no need to do a lagrange multiplier test.

3. Classical Assumption Test Results

Multicollinearity Test

Basuki and Prawoto (2017:62) states that the multicollinearity test aims to test whether in the regression model a high or perfect correlation is found between the independent variables.

- If the Centered VIF value < 10 then multicollinearity does not occur.
- If the Centered VIF value > 10 , multicollinearity occurs.

The results of the multicollinearity test with Eviews 12 can be seen in table 4.9 as follows:

Table 4.7
Multicollinearity Test Results

Variance Inflation Factors
Date: 06/21/22 Time: 04:43
Sample: 1 215
Included observations: 215

Variable	Coefficient Variance	Uncentered VIF	Centered VIF
C	0.004287	2.764373	NA
X1	0.086178	1.033813	1.014580
X2	0.000181	2.716344	1.014580

Source: Results of data processing with Eviews 12

Based on table 4.7 it can be seen that the Centered VIF value above shows that there is no VIF value greater than 10. Where the VIF value for the tax avoidance variable (X1) and the capital structure variable (X2) is 1.014580, thus this regression model is proven multicollinearity does not occur.

Heteroscedasticity Test

The heteroscedasticity test in this study used the white heteroscedasticity test with the following hypotheses:

H0 : There is no heteroscedasticity.

H1 : There is heteroscedasticity.

- If Prob. Chi-square < 0.05 , then H0 is rejected, H1 is accepted so there is no heteroscedasticity in the model.
- If Prob. Chi-square > 0.05 , then H1 is rejected, H0 is accepted so there is heteroscedasticity in the model.

The results of the heteroscedasticity test with Eviews 12 can be seen in table 4.8 as follows:

Table 4.8 Heteroscedasticity Test Results

Heteroskedasticity Test: White
Null hypothesis: Homoskedasticity

F-statistic	1.955721	Prob. F(2,212)	0.1440
Obs*R-squared	3.894931	Prob. Chi-Square(2)	0.1426
Scaled explained SS	36.60213	Prob. Chi-Square(2)	0.0000

Source: Results of data processing with Eviews 12

Based on the results of the heteroscedasticity test above, the Prob. Chi-Square 0.1426 > 0.05 so it can be concluded that H0 is accepted, meaning that there is no heteroscedasticity in this study.

4. Panel Data Regression Test Results

Based on the series of tests that have been carried out, the final regression model of this study uses the fixed effect model. The following is a summary of the fixed effect models used in the research model.

Table 4.9 Panel Data Regression Test Results

Variable	Coefficient	Std. Error	t-Statistic	Prob.
C	0.132531	0.074956	1.768125	0.0788
X1	0.003177	0.030002	0.105900	0.9158
X2	-0.090532	0.038811	-2.332619	0.0208
Effects Specification				
Cross-section fixed (dummy variables)				
R-squared	0.667826	Mean dependent var	0.046512	
Adjusted R-squared	0.581852	S.D. dependent var	0.395860	
S.E. of regression	0.255980	Akaike info criterion	0.296332	
Sum squared resid	11.13940	Schwarz criterion	1.001815	
Log likelihood	13.14429	Hannan-Quinn criter.	0.581380	
F-statistic	7.767743	Durbin-Watson stat	2.234955	
Prob(F-statistic)	0.000000			

Source: Results of data processing with Eviews 12

Table 4.9 shows the results of panel data regression analysis with the fixed effect model approach. From the table above, it can be seen that the regression equation is as follows:

$$Y = 0.132531 + 0.003177X1 - 0.090532X2 + \varepsilon$$

The regression equation is as follows:

Constant (a)

The constant value in the panel data regression model is known to be 0.132531, meaning that if the independent variable consisting of tax avoidance (X1) and capital structure (X2) is equal to (zero), the firm value with the Tobins'Q proxy is equal to 0.132531 units .

Tax Avoidance(X1)

The coefficient value for the tax avoidance variable (X1) which is proxied by the effective tax rate (ETR) is known to be 0.003177 which has a positive or unidirectional



direction. This means that every increase in the value of the tax avoidance variable (X1) by one unit or an increase of 1% will be followed by a decrease in the company value variable (Y) by 0.003177 units.

Capital Structure (X2)

The coefficient value for the capital structure variable (X2) which is proxied by the debt to equity ratio (DER) is known to be -0.090532 which has a negative or not unidirectional direction. This means that every increase in the value of the capital structure variable (X2) by one unit or an increase of 1% will be followed by a decrease in the company value variable (Y) of -0.090532 units.

5. Hypothesis Test Results

Determination Coefficient Test (R2)

The coefficient of determination (R2) is a test that explains the effect of the independent variables on the dependent variable. If there are other independent variables, R squared will be very sensitive. If the R squared value has more independent variables, the squared will be higher (Krisyadi and Triana, 2021).

The results of the test for the coefficient of determination (R2) with Eviews 12 from the research data can be seen in table 4.9 as follows:

Table 4.10 Results of the R2 Determination Test

R-squared	0.667826
Adjusted R-squared	0.581852

Source: Results of data processing with Eviews 12

Based on table 4.10 above, it can be seen that the R² value is 0.667826 or 66%. That is, the ability of the independent variables in this study, namely tax avoidance and capital structure, can explain the dependent variable, namely firm value of 66.7%, while the rest (100% - 66.7% = 33.3%) is explained by other variables outside the model.

F Test (Simultaneous)

Krisyadi and Triana (2021) explains that the f test is used to test the effect of the independent variables on the dependent variable simultaneously. The significance value shows <0.05, meaning the model used is appropriate. The significance value shows > 0.05 meaning that the independent variable has no effect on the dependent variable simultaneously.

The results of the F test with Eviews 12 from this research data can be seen in table 4.10 as follows:

Table 4.11 F Test Results

F-statistic	7.767743
Prob(F-statistic)	0.000000

Source: Results of data processing with Eviews 12

Based on table 4.11, the F-statistic value is 7.767743 with a probability (Prob F-Statistic) of 0.000000 <0.05.

T Test (Partial)

Krisyadi and Triana (2021) explains that the t test is used to test the dependent variable that is affected by each independent variable.

- If the significance value shows <0.05 , it indicates that the independent variable has a significant influence on the dependent variable.
- If the significance value shows > 0.05 , it indicates that the independent variable has no significant effect on the dependent variable.

The results of the T test with Eviews 12 from this research data can be seen in table 4.13 as follows:

Table 4. 11 T test results

Variable	Coefficient	Std. Error	t-Statistic	Prob.
C	0.132531	0.074956	1.768125	0.0788
X1	0.003177	0.030002	0.105900	0.9158
X2	-0.090532	0.038811	-2.332619	0.0208

Source: Results of data processing with Eviews 12

From table 4.11 above, it shows the decision to test the t statistic or partial test that the t-statistic value is 0.105900 and shows the probability value of X1 is $0.9158 > 0.05$ so H_0 is accepted, which means that the tax avoidance variable (X1) has no effect significant to the firm value variable. Thus H_1 which states that tax avoidance partially affects firm value is rejected.

While the t-statistic value is -2.332619 and shows the probability value of capital structure (X2) of $0.0208 < 0.05$ so that H_0 is accepted, which means that the capital structure variable (X2) has a significant effect on firm value. Thus H_2 which states that capital structure partially influences firm value is accepted.

Effect of Tax Avoidance on Firm Value

Based on the results of statistical tests it is known that the significance value is $0.9158 > 0.05$, it can be concluded that tax avoidance partially has no effect on firm value. While the coefficient value of the tax avoidance variable which is proxied by the Effective Tax Rate (ETR) shows a value of 0.003177, these results indicate that the tax avoidance variable has a positive or unidirectional direction. This means that if the tax avoidance variable increases by one unit, it will increase the firm value by 0.003177 assuming the independent variable remains constant.

The results of statistical tests show that tax avoidance has a positive but not significant effect on firm value. That is, the average research data in financial companies is 23.6% that implement tax avoidance or very small so that tax avoidance has a positive but not significant effect on firm value.

The results of this study are in line with research conducted by Asa and Utomo (2019), Holiawati and Murwaningsari (2019), Wirianto et al. (2021), as well as Krisyadi and Triana (2021) explains that tax avoidance has a positive but not significant effect on firm value.



Effect of Capital Structure on Firm Value

Based on the results of statistical tests it is known that the significance value is $0.0208 < 0.05$, it can be concluded that capital structure partially affects firm value. While the coefficient value of the capital structure variable proxied by the Debt to Equity Ratio (DER) shows a value of -0.090532 , these results indicate that the tax avoidance variable has a negative direction or not in the same direction. This means that if the capital structure variable increases by one unit, it will reduce the company's value by -0.090532 by assuming the independent variables are fixed.

The results of statistical tests show that capital structure has a negative and significant effect on firm value. This is because, the addition of debt can increase the possibility of experiencing the risk of financial distress (financial distress) because the company continues to bear interest expenses.

However, if the capital structure assumption is not optimal, then any increase in debt below the optimal limit will increase the value of the company. In addition, Lenders as well as investors on the Stock Exchange generally consider companies with low DER. Consideration of these reasons so that their investment interests are better protected from the potential decline in business for the company concerned. The results of this study are in line with research conducted by Siregar et al. (2019) states that capital structure has a negative and significant effect on firm value.

CONCLUSION

Based on the results of research and discussion regarding the effect of financial decisions and ownership structure on company value in financial companies listed on the Indonesia Stock Exchange for the period 2017 - 2021 the following conclusions can be drawn:

Tax Avoidance as measured by the ETR ratio has a positive but not significant effect on company value as measured by the Tobins'Q ratio in financial companies listed on the Indonesia Stock Exchange for the period 2017 - 2021. This is because the average research data in financial companies is 23.6% those who carry out tax avoidance or very small so that tax avoidance has a positive but not significant effect on firm value.

Capital structure as measured by the DER ratio has a negative and significant effect on company value as measured by the Tobins'Q ratio for financial companies listed on the Indonesia Stock Exchange for the period 2017 – 2021. This is because additional debt can increase the likelihood of experiencing the risk of financial difficulties (financial distress) because the company continues to bear the interest expense. Because it is indicated that the capital structure is no longer optimum, any increase in debt above the optimum limit will reduce the value of the company.

REFERENCES

- Aggarwal, Divya, and Purna Chandra Padhan. 2017. 'Impact of Capital Structure on Firm Value: Evidence from Indian Hospitality Industry'. *Theoretical Economics Letters* 07(04):982–1000. doi: 10.4236/tel.2017.74067.
- Apsari, Lina, and Putu Ery Setiawan. 2018. 'Pengaruh Tax Avoidance Terhadap Nilai Perusahaan Dengan Kebijakan Dividen Sebagai Variabel Moderasi'. *E-Jurnal Akuntansi* 23(3):1765–90. doi: 10.24843/eja.2018.v23.i03.p06.
- Arfiansyah, Zef. 2020. 'Pengaruh Penghindaran Pajak Dan Risiko Pajak Terhadap Nilai Perusahaan Dengan Komisaris Independen Sebagai Pemoderasi'. *JURNAL PAJAK INDONESIA (Indonesian Tax Review)* 4(2):67–76. doi: 10.31092/jpi.v4i2.1436.
- Asa, Citra Ratusan, and Dwi Cahyo Utomo. 2019. 'Pengaruh Praktik Penghindaran Pajak Terhadap Nilai Perusahaan Dan Biaya Agensi Dengan Transparansi Informasi Sebagai Variabel Moderating (Studi Empiris Pada Perusahaan Manufaktur Yang Terdaftar Di BEI Tahun 2015-2017)'. *Diponegoro Journal of Accounting* 8(3):1–15.
- Basuki, Agus Tri, and Nano Prawoto. 2017. *Analisis Regresi Dalam Penelitian Ekonomi & Bisnis (Dilengkapi Aplikasi SPSS & Eviews)*. Jakarta: Rajawali Pers.
- Devi, Novita Shinta, and Yusvita Nena Arinta. 2021. 'Pengaruh Size Company, Profitabilitas, Dan Likuiditas Terhadap Tax Avoidance Dengan Struktur Modal Sebagai Variabel Intervening Pada Bank Umum Syariah Di Indonesia'. 1(2):96–107.
- Eskandarlee, Taher, and Taj Mohammad Sadri. 2017. 'Impact of Management Ability on Relationship between Tax Avoidance and Firm Value in Companies Listed in Tehran Stock Exchange'. *Revista QUID* 1(1):1859–68.
- Fauziah, Izza Noor, and Bambang Sudyatno. 2020. 'Pengaruh Profitabilitas Dan Pertumbuhan Perusahaan Terhadap Nilai Perusahaan Dengan Struktur Modal Sebagai Variabel Moderasi (Studi Kasus Pada Perusahaan Manufaktur Yang Terdaftar Di BEI Periode 2016-2018)'. *Dinamika Akuntansi, Keuangan Dan Perbankan* 9(2):107–18.
- Hidayat, Wastam Wahyu. 2018. 'Determinan Struktur Modal Dan Dampaknya Terhadap Nilai Perusahaan'.
- Holiawati, and Ety Murwaningsari. 2019. 'Intellectual Capital, Tax Avoidance and Firm Value'. *International Journal of Business, Economics and Law* 18(5):219–27.
- Irawan, Dedi, and Nurhadi Kusuma. 2019. 'Pengaruh Struktur Modal Dan Ukuran Perusahaan Terhadap Nilai Perusahaan'. *Jurnal AKTUAL* 17(1):66–81. doi: 10.47232/aktual.v17i1.34.
- Israel, Cristy, Marjam Mangantar, and Ivonne S. Saerang. 2018. 'Pengaruh Struktur Modal, Kepemilikan Institusional Dan Ukuran Perusahaan Terhadap Nilai Perusahaan Pada Perusahaan Pertambangan Yang Terdaftar Di Bei'. *Jurnal EMBA: Jurnal Riset Ekonomi, Manajemen, Bisnis Dan Akuntansi* 6(3):1118–27. doi: 10.35794/emba.v6i3.20073.
- Jensen, Michael C., and William H. Meckling. 1976. 'Theory Of The Firm : Managerial Behavior, Agency Costs And Ownership Structure'. *Journal of Financial Economics* 3 305–60. doi: 10.1177/0018726718812602.
- Kartika, Andi, Sri Sudarsi, and Moch Irsad. 2019. 'Peran Pemoderasi Transparansi Informasi : Penghindaran Pajak Dan Nilai Perusahaan (Studi Empiris Pada Perusahaan Manufaktur Di Indonesia)'. *Fokus Ekonomi : Jurnal Ilmiah Ekonomi* 14(2):407–18. doi: 10.34152/fe.14.2.407-418.
- Krisyadi, Robby, and Marmileni Triana. 2021. 'Pengaruh Penghindaran Pajak, Persentase Dan Massa Kritis Direktur Wanita Terhadap Nilai Perusahaan'. *Jurnal Ilmiah Akuntansi Dan Keuangan* 04(01):400–413.
- Mappadang, Agoestina. 2019. 'Do Corporate Governance Mechanism Influences Tax Avoidance and Firm Value?'. *International Journal of Academic Research in Business and Social Sciences* 9(10):203–17. doi: 10.6007/ijarbs/v9-i10/6478.
- Maulana, Anggi, Ratna Hindria Dyah Pita Sari, and Ekawati Jati Wibawaningsih. 2021. 'Analisis Pengaruh Kompensasi Eksekutif, Profitabilitas Perusahaan Dan Leverage Terhadap Tax Avoidance'. *Konferensi Riset Nasional Ekonomi, Manajemen, Dan Akuntansi* 2:1151–70.
- Megawati, Farah Tri, Nana Umdiana, and Lulu Nailufaroh. 2021. 'Faktor-Faktor Struktur Modal Menurut Trade Off Theory'. *Jurnal Akuntansi Dan Keuangan* 26(1):55–67. doi: 10.23960/jak.v26i1.255.



- Modigliani, Franco, and Merton H. Miller. 1963. 'Corporate Income Taxes and the Cost of Capital: A Correction'. *American Economic Review* 53(3):433–43. doi: 10.2307/1809167.
- Mudjijah, Slamet, Zulvia Khalid, and Diah Ayu Sekar Astuti. 2019. 'Pengaruh Kinerja Keuangan Dan Struktur Modal Terhadap Nilai Perusahaan Yang Dimoderasi Variabel Ukuran Perusahaan'. *Jurnal Akuntansi Dan Keuangan* 8(1):41–56.
- Nugraha, Made Caesar Juliartha, and Putu Ery Setiawan. 2019. 'Pengaruh Penghindaran Pajak (Tax Avoidance) Pada Nilai Perusahaan Dengan Transparansi Sebagai Variabel Pemoderasi'. *E-Jurnal Akuntansi Universitas Udayana* 26(1):398–425. doi: 10.24843/eja.2019.v26.i01.p15.
- Nurazi, Ridwan, Intan Zoraya, and Akram Harmoni Wiardi. 2020. 'The Influence Of Good Corporate Governance And Capital Structure On Firm Value: The Mediation Role Of Financial Performance'. *Media Ekonomi Dan Manajemen* 35(2):230–42.
- Nurfadilah, Rianita, and Zulfa Rosharlianti. 2020. 'The Effect of Tax Avoidance and Debt Policy on Firm Value with Institutional Ownership as Moderating Variable in Indonesian Manufacturing Companies'. *PROCEEDING Call for Paper – 2nd International Seminar on Accounting Society* 147–56.
- Nursolehudin, Selji Salgangga, Irma Rahmika, Nina Herlina, and Andi Rustandi. 2019. 'Pengaruh Rasio Struktur Modal Dan Profitabilitas Terhadap Nilai Perusahaan (Suatu Studi Pada PT Kimia Farma Tbk. Periode 2012 - 2016)'. 1(1):140–53.
- Oktaviani, Rachmawati Meita, Desy Tri Susanti, Sunarto Sunarto, and Udin Udin. 2019. 'The Effect of Profitability, Tax Avoidance and Information Transparency on Firm Value: An Empirical Study in Indonesia'. *International Journal of Scientific and Technology Research* 8(11):3777–80.
- Putri, Mayke Kristika Antony, and Gunasti Hudiwinarsih. 2018. 'Analysis of Factors Affecting Tax Avoidance and Firm Value'. *The Indonesian Accounting Review* 8(2):205–17. doi: 10.14414/tiar.v8i2.1538.
- Radina, Linantis, Dwi Orbaningsih, and Oyong Lisa. 2021. 'Transparency as Moderating Tax Avoidance, Profitability, and Leverage on Firm Value'. *Journal of Economics, Finance And Management Studies* 04(12):2415–26. doi: 10.47191/jefms/v4-i12-02.
- Ramdhonah, Zahra, Ikin Solikin, and Maya Sari. 2019. 'Pengaruh Struktur Modal, Ukuran Perusahaan, Pertumbuhan Perusahaan, Dan Profitabilitas Terhadap Nilai Perusahaan (Studi Empiris Pada Perusahaan Sektor Pertambangan Yang Terdaftar Di Bursa Efek Indonesia Tahun 2011-2017)'. *JURNAL RISET AKUNTANSI DAN KEUANGAN* 7(1):67–82. doi: 10.25134/ijsm.v2i1.1859.
- Revi, Armana I. Made, and Purbawangsa Ida Bagus Anom. 2021. 'The Effect of Profitability, Firm Size, Capital Structure and Tax Avoidance on Firm Value'. *Russian Journal of Agricultural and Socio-Economic Sciences* 119(11):31–40. doi: 10.18551/rjoas.2021-11.04.
- Ross, Stephen A. 1977. 'Determination of Financial Structure: The Incentive-Signalling Approach.' *Bell J Econ* 8(1):23–40. doi: 10.2307/3003485.
- Rukajat, Ajat. 2018. *Pendekatan Penelitian Kuantitatif*. Sleman: Budi Utama.
- Sadewo, Iron Bakti, Irianing Suparlinah, and Rini Widianingsih. 2017. 'Pengaruh Ukuran Perusahaan Dan Keputusan Pendanaan Terhadap Nilai Perusahaan Dengan Profitabilitas Sebagai Variabel Mediasi'. *Jurnal Akuntansi Dan Sistem Teknologi Informasi* 13(3):126–45.
- Sartono, Sawal, and Tri Ratnawati. 2020. 'Faktor-Faktor Penentu Struktur Modal'. *Jurnal Ekonomi & Manajemen* 11(1):35–44.
- Setiawan, Muhammad Rhamadan, Neneng Susanti, and Nugi Mohammad Nugraha. 2021. 'Pengaruh Struktur Modal, Perputaran Modal Kerja, Dan Ukuran Perusahaan Terhadap Nilai Perusahaan'. *Owner* 208–18. doi: 10.33395/owner.v5i1.383.
- Siregar, M. Edo Suryawan, Sholatia Dalimunthe, and Rony Safri Trijunianto. 2019. 'Pengaruh Profitabilitas, Ukuran Perusahaan, Kebijakan Dividen Dan Struktur Modal Terhadap Nilai Perusahaan Pada Perusahaan Manufaktur Yang Terdaftar Di Bursa Efek Indonesia Periode 2015-2017'. *Jurnal Riset Manajemen Sains Indonesia (JRMSI)* 10(2):356–85.
- Spence, Michael. 1973. 'Job Market Signaling'. *The Quarterly Journal of Economics* 87(3):355–74.

Accounting Inquiries with New Approaches in the Post-Pandemic Era
Volume I

- Suzulia, Maya Topani, Sudjono, and Ahmad Badawi Saluy. 2020. 'The Effect Of Capital Structure, Company Growth, And Inflation On Firm Value With Profitability As Intervening Variable (Study On Manufacturing Companies Listed On Bei Period 2014 - 2018)'. 1(1):2721–3021. doi: 10.38035/DIJEFA.
- Syamsudin, Syamsudin, Anton Agus Setyawan, and Aflit Nuryulia Praswati. 2020. 'Corporate Governance and Firm Value: A Moderating Effect of Capital Structure'. *International Journal of Innovation, Creativity and Change* 12(2):264–77.
- Tobin, James. 1969. 'A General Equilibrium Approach To Monetary Theory'. *Journal of Money, Credit and Banking* 1(1):15–29.
- Uzliawati, L., A. Yuliana, Y. Januarsi, and M. I. Santoso. 2018. 'Optimisation of Capital Structure and Firm Value'. *European Research Studies Journal* 21(2):705–13. doi: 10.35808/ersj/1034.
- Wirianto, Dhani, Helmi Yazid, and Agus Sholikhhan Yulianto. 2021. 'Efek Moderasi Kebijakan Dividen Dan Kepemilikan Institusional Pada Hubungan Tax Avoidance Dan Nilai Perusahaan (Studi Empiris Pada Perusahaan Indeks LQ45 Periode 2015-2019)'. *Audit and Accounting Guide* 4(5):1715–38. doi: 10.1002/9781119558361.ch20.
- Yanti, I. Gusti Ayu Diah Novita, and Ni Putu Ayu Darmayanti. 2019. 'Pengaruh Profitabilitas, Ukuran Perusahaan, Struktur Modal, Dan Likuiditas Terhadap Nilai Perusahaan Makanan Dan Minuman'. *E-Jurnal Manajemen Universitas Udayana* 8(4):2297. doi: 10.24843/ejmunud.2019.v08.i04.p15.
- Zulfiara, Puradinda, and Juli Ismanto. 2020. 'Pengaruh Konservatisme Akuntansi Dan Penghindaran Pajak Terhadap Nilai Perusahaan'. *Jurnal Akuntansi Berkelanjutan Indonesia* 2(2):134. doi: 10.32493/jabi.v2i2.y2019.p134-147.

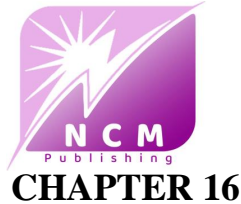

Revolutionizing Digital Transformation: The Rise of digital banking in regional development banks in Indonesia

EKA RIZKI SUKMADEWI, SS

Sekolah Tinggi Manajemen IPMI

eka.sukmadewi@IPMI.ac.id

Orcid: 0009-0009-5731-3650

Ir. Amelia Naim INDRAJAYA, MBA

Sekolah Tinggi Management IPMI

amelia.naim@ipmi.ac.id

Orcid: 0000-0001-9021-902X

ABSTRACT

The paper examines the evolution of digital banking in Indonesian regional banks, with a focus on the strategies and obstacles experienced by these institutions in adopting and implementing digital banking technologies. As technology continues to disrupt the global financial environment, regional banks in Indonesia are increasingly understanding the necessity of digital transformation to remain competitive and satisfy their clients' shifting expectations. The research investigates regional banks' different digital banking projects, such as mobile banking applications, online account management, and electronic payment systems. It also emphasizes the advantages of digital banking, such as increased client convenience, greater operational efficiency, and extended market reach. However, the paper also highlights the barriers to digital banking that regional banks confront, such as insufficient technological infrastructure, security issues, and client trust. The findings indicate that, while regional banks have made headway in implementing digital banking, more investment in technology, regulatory assistance, and consumer education is still required. Finally, this study adds to our understanding of Indonesia's digital banking ecosystem, offering vital information for regional banks and regulators as they negotiate the way to a more digitally inclusive and strong banking industry.

Keywords: Regional banks, Digital banking, Investment, Regulatory support.

INTRODUCTION

Current technological developments cannot be avoided along with changes in human behavior in various economic and social activities, from conventional to automation systems or moving to all things that are electronic. The financial sector is no exception; the application of digital banking is a must that must be implemented. For example, there is a shift in payment transactions from previously all-cash to non-cash (cashless). Payment instruments that were originally in paper form have also begun to shift to debit or credit cards and can even be made using a mobile phone. The dominance of millennials has strengthened digital banking trends, such as increasing the use of mobile banking or internet banking, which is common; moreover, there are no restrictions on the number of transactions; both small and large nominal transactions can be done via gadgets.

Digital banking itself is not easy to implement; this is due to regulation and supervision by many regulators accompanied by strict rules. This aims to regulate banking operations to maintain governance, mitigate risk, and ensure bank management complies with these rules. Therefore, banks cannot innovate freely without approval and monitoring from regulators. Initially, the development of digital banking was only intended for large banks. This was because large banks were believed to fulfill aspects such as having strong capital, adequate infrastructure, and capable human resources. In contrast to large banks, banks with medium and even small assets are considered unable to manage digital products and services properly due to their limitations. Small banks have limitations such as relatively small capital, insufficient infrastructure, and inadequately knowledgeable human resources. The fundamental challenge for small banks is that a fixed mindset will make digital transformation difficult.

While the need to increase competitiveness in the banking industry does not recognize bank size, all categories of commercial and rural banks, conventional banks, and Sharia-oriented banks face intense business competition. For information, currently, Indonesia is divided into two categories of banks: commercial banks and people's credit banks (BPR). For this reason, financial institutions such as banks need to improve the quality of service, they provide to customers to optimize their financial performance.

The use of digital banking is also expected to increase transparency and accountability in the management of a bank; this is evidenced by the existence of a digital track record system. The use of digital banking can generate customer satisfaction and loyalty. The presence of online banking provides easier access with the availability of banking services 24 hours a day, making it easy to make transactions anytime and anywhere. This has an impact on a wider range of services, so as to increase the customer base, expand business scale, and improve financial performance.

The Regional Development Bank, or BPD, was established based on Law No. 13 of 1962 concerning the Main Provisions of Regional Development Banks (BPD) with the specific intention of providing financing for the implementation of regional development efforts within the framework of the Universal National Development Plan (Article 4). In line with the mandate of the law, BPD provides loans for investment purposes, expansion, and renewal of development projects in the regions (Article 5), both those held by the regions and those held by mixed companies between the regional government and the private sector. In general, BPDs, which are included in the category of commercial banks, also experience challenges and obstacles, but because BPDs are located in the region and owned by the regional



government, the problems they face are quite complex compared to commercial banks owned by the central government.

SWOT Analysis BPD SI

<p>S</p> <ul style="list-style-type: none"> - Local government ownership - Regional banks and captive markets - High profitability, high NIM, ROA, and ROE 	<p>W</p> <ul style="list-style-type: none"> - Small assets and capital vs. peers and industry - Weak corporate governance, risk management, and compliance - Local government support is lacking. - Low competitiveness
<p>O</p> <ul style="list-style-type: none"> - BPD group business synergy - The potential of the domestic market, especially MSME loans, is high. - Development of e-commerce - Support from regulators and stakeholders 	<p>T</p> <ul style="list-style-type: none"> - Downside risks from the international, regional, and domestic economies - The competition is getting sharper, MEA. - Prudential regulations are getting stricter according to national standards. - Contribution to the regional economy according to the mission in the law

(BPD's transformation book, 2015)

LITERATURE REVIEW

Digital banking has transformed the Indonesian regional development banking sector with the introduction of mobile banking, online account management, and electronic payment solutions. The birth of banking technology took place with the arrival of plastic cards and Automated Teller Machines (ATM) in the 1960s'. Later, in 1983, when the internet came into existence, there was a sudden disruption of technology in the banking industry. Banks that were housed in brick-and-mortar structures started reaching the doorsteps of customers through the internet. Two major devices that made the banking technology disruption to reach the hands of the people were smartphones (web application) and computers (website). Similarly, disruptions also evolved these devices, which eventually led to cost effective and efficient technology to progress faster. In spite of technology disruptions that were being

heralded as a positive sign for all such benefits that it had brought, it also had its own set of challenges and issues in the form of security (Sundaran, Thomas, and Agilandeewari, 2019)

Regional banks have embraced these technologies to reach customers across different regions at any time. Phone banking enables customers to access services 24/7, while SMS banking allows transactions through mobile messages. Mobile banking applications offer convenience and eliminate the need to remember SMS formats and internet banking provides a range of services through bank websites. These advancements have enhanced customer accessibility, and operational efficiency, and positioned regional banks to meet evolving customer expectations in the dynamic digital banking landscape.

Fintech has brought about significant changes in the financial industry, presenting a potential threat to Regional Development Banks (BPD) in Indonesia. BPDs face the risk of losing market share to fintech companies, the disintermediation of traditional banking services, and the need to invest in technology infrastructure and digital capabilities. To counter the fintech threat, BPDs should consider digital transformation, partnering with fintech companies, or developing their own fintech solutions.

BPD has a strategic role in accelerating economic growth and regional development, with the main task of developing the economy and driving regional development. The evolution of technological developments is also faced by BPDs, adding to the root of the problems of BPDs, namely low competitiveness, weak GCG, and support from stakeholders, especially the Regional Government as shareholders, to transform BPDs into obstacles to innovation, especially in implementing digital banking.

The weakness of the BPD's business sustainability and the implementation of its role as a regional development agent is the impact of weak competitiveness rooted in the "high comfort zone" of captive market protection. BPD is made by segmentation owned by the regional government with the ASN/PNS core business, so the development of digital banking is considered less attractive because it already has a clear source of income, so efforts to innovate in creating new programs or improving financial performance quality services are low. However, this cannot be ignored. There is business competition with other commercial banks, forcing BPD to make structural improvements so that it is able to take advantage of opportunities and compete in an increasingly competitive environment.

There are 27 (twenty-seven) BPD SI spread throughout Indonesia, located in every provincial capital, but not all BPDs have digital banking service products; this is due to the regulator. The application of digital banking services is regulated in the Financial Services Authority Regulation (POJK) Number 12/POJK.3/2018 concerning the Implementation of Digital Banking Services by Commercial Banks, which is stated as a requirement for implementing banks: "Bank groups based on business activities as stipulated in OJK regulations that can provide services in electronic banking" (Article 18). This is the main obstacle why BPDs have not been able to apply digital banking services evenly, given the amount of core capital of BPDs, which is divided into several clusters.



Core Capital regional development banking.

June 2022

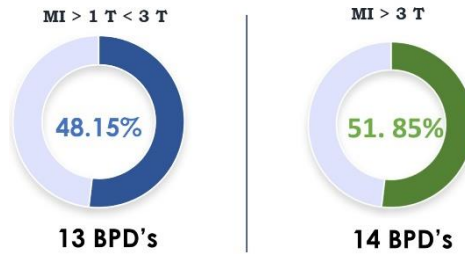

Sources: Asbanda Financial Report 2022

To overcome technological developments, BPD continues to try to adapt the digital service system to various existing limitations. Through the BPD SI transformation program, BPD agreed to carry out interbank switching, smart practices, biller/payment integration, and government program integration. These activities are implemented through a program called BPD Net Online. BPD Net Online is a delivery channel network managed by external parties that can be used by BPDs throughout Indonesia. Through BPD Net Online, BPD SI can collaborate by providing an integrated service system between one BPD and other BPDs; for example, Bank Aceh customers can perform digital banking services through Bank DKI ATM machines.

The History of banking technology

Pre- 1990s	1991-2008	2009-2015	Post- 2015
<ul style="list-style-type: none"> Limited to physical branches Cash Intensive Custodian of cash and valuables Check: primary mode of payments Electronic payment system for domestic and international transfers 	<ul style="list-style-type: none"> World wide web ATMs, cards PCs Birth of non-banking disruptors like Google, Amazon, Papal, Facebook, and Apple iPhone Burst of the dot-com bubble Internet-based banking Check digitalization. Collapse of the US Banking system in 2008 	<ul style="list-style-type: none"> Tightening of regulatory norms Smartphone era: moving from PCs to mobile. Mobile banking Mobile POS Kodak and Nokia file for bankruptcy 24/7 banking Apple pay 	<ul style="list-style-type: none"> VC funding startups Fintech disruption mobile wallets Conversation banking Chatbots Banking as a platform Experiential, personalized banking
Mainframes ARPANET SWIFT	Check Truncation System Real-Time Payments (RTP) Web-based applications	Artificial Intelligence (AI) Bitcoin Big Data Analytics	Cognitive AI Open Banking Predictive analytics

**Accounting Inquiries with New Approaches in the Post-Pandemic Era
Volume I**

Source: Infosys (2019)

IT Based Product
June 23

No	Bank	Mobile Banking	Internet Banking	SMS Banking	Electronic Money Server Based	Electronic Money Chip Based	Cash Management System
1	Bank Aceh Syariah	Yes	No	Yes	No	No	Yes
2	Bank Sumut	Yes	Yes	Yes	No	Yes	Yes
3	Bank Riau Kepri	Yes	No	Yes	No	Yes	Yes
4	Bank Nagari	Yes	Yes	Yes	Yes	No	Yes
5	Bank Jambi	Yes	No	No	No	No	Yes
6	Bank Bengkulu	Yes	No	Yes	No	No	No
7	Bank Sumsel Babel	Yes	Yes	Yes	No	Yes	Yes
8	Bank Lampung	Yes	No	Yes	No	Yes	Yes
9	Bank DKI	Yes	Yes	No	Yes	Yes	Yes
10	Bank bjb	Yes	Yes	Yes	Yes	No	Yes
11	Bank Jateng	Yes	Yes	No	No	No	Yes
12	Bank BPD DIY	Yes	Yes	Yes	Yes	Yes	Yes
13	Bank Jatim	Yes	Yes	Yes	No	No	Yes
14	Bank Kalbar	Yes	No	Yes	No	Yes	Yes
15	Bank Kalsel	Yes	No	Yes	Yes	Yes	Yes
16	Bank Kalteng	Yes	No	Yes	No	No	Yes
17	Bank Kaltimlara	Yes	Yes	Yes	No	No	Yes
18	Bank BPD Bali	Yes	Yes	No	No	Yes	Yes
19	Bank NTB Syariah	Yes	Yes	Yes	Yes	No	Yes
20	Bank NTT	Yes	No	Yes	No	No	Yes
21	Bank SulutGo	Yes	No	Yes	No	Yes	Yes
22	Bank Sulteng	No	No	Yes	No	No	No
23	Bank Sultra	No	No	Yes	No	No	No
24	Bank Sulselbar	Yes	Yes	No	Yes	Yes	Yes
25	Bank MalukuMalut	Yes	No	Yes	No	No	No
26	Bank Papua	Yes	No	Yes	No	No	Yes
27	Bank Banten	No	No	No	No	No	No

Sources: Asbanda Financial Report 2022

RESEARCH METHODOLOGY

In the literature review, the focus of research usually leads to an understanding of the development of digital banking and the factors that influence it. This also includes an evaluation of the speed and obstacles to implementing digital banking. Research reference searches include both online and offline materials for journal articles and chapters in a book. Questionnaires will be distributed to prove the truth of the hypothesis. Research reference searches include both online and offline materials for journal articles and chapters in a book.



Questionnaires will be distributed to prove the truth of the hypothesis. Narrative review consists of critical analysis of the literature published in books and electronic or paper-based journal articles. (Rother, 2007). Reference-based on online databases such as Web of Science and Google Scholar. The use of references is based on research material on the same topic as this research. Finally, the limitations of this study and future research directions are suggested.

RESEARCH QUESTION AND HYPOTHESIS

This paper has 5 research questions, and the research framework is seen below:

- How have digital banking technology influenced Indonesian regional banks, increasing the customer accessibility and operational efficiency?
- What are the possible obstacles and risks that fintech poses to Indonesian Regional Development Banks (BPDs), and how can BPDs reduce these risks through digital transformation or fintech collaborations?
- What factors contribute to BPDs' low competitiveness and lack of assistance in implementing digital banking, and how does this affect their sustainability in the future and role in regional development?
- How does the lack of innovation caused by captive market protection limit the development of digital banking in BPDs, and how can this barrier be overcome?
- What are the challenges and gaps in implementing digital banking services among BPDs in Indonesia, as influenced by the Banking and Financial Services Authority's regulatory framework and requirements?

Digital banking provides many benefits to the banking business.

Hypothesis 1: Digital banking has improved client access and operational efficiency in Indonesian regional development banks.

Hypothesis 2: Fintech is a challenge to regional development banks, demanding digital transformation or collaboration to compensate for market share loss.

Hypothesis 3: BPDs' digital banking implementation and sustainability are limited by low competitiveness and insufficient stakeholder support.

Hypothesis 4: Due to captive market protection, BPDs experience obstacles in implementing digital banking, but competition increases the need for innovation.

Hypothesis 5: Differences in digital banking implementation among BPDs depending on core capital and business activities are caused by regulatory restrictions.

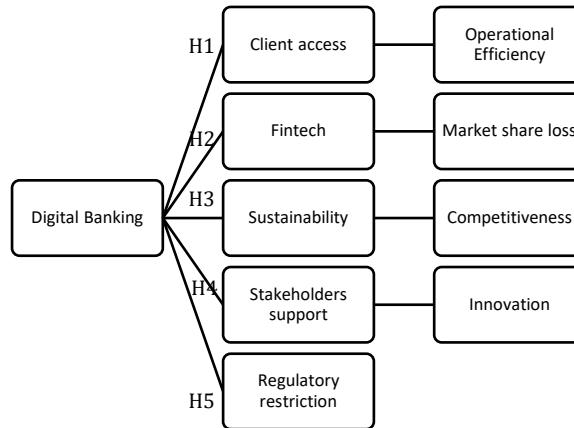

Table: Research Frame work

FINDINGS AND DISCUSSION

Based on this finding and discussion, BPD is currently running a program called BPD Transformation. They collaborate and join in the process of building a platform called Go Smart Platform (BPD One). BPD One is a platform that provides all digital finance access, and the platform is divided into categories such as Go Government, Go Branding, Go Economy, Go Living, Go Society, and Go Environment.



BPD's Transformation logo



BPD is being digitally Transformed through Go Smart City

Go Smart Platform



The author finds the challenges and opportunities of developing digital banking at regional bank development. The establishment of regional banks faces several challenges that must be addressed: For beginnings, regional banks sometimes confront infrastructure limits that hamper the efficient integration of digital banking services. These restrictions include slow or inconsistent internet connections, limited hardware, and a lack of experienced IT resources. Second, the security and privacy of sensitive information and consumer data is critical. Cyber-attacks and data leaks destroy client trust, making widespread adoption of digital banking difficult. To protect against such attacks, regional banks must develop rigorous security safeguards and privacy regulations. Third, there is a knowledge and skills gap that regional banks must fill. Improving their workforce's knowledge and skills is critical for the smooth operation and management of digital banking services. This includes adopting appropriate training and education activities to ensure personnel have the requisite experience in navigating digital platforms, knowing cybersecurity rules, and providing exceptional digital customer service. Addressing these issues is crucial for regional banks to embrace digital transformation successfully. Regional banks may overcome these challenges and benefit on the potential given by the digital banking era by investing in their technology infrastructure, enhancing security measures, and providing comprehensive education programs.

Regional banks have several potential as digital banking develops. To begin with, digital platforms allow regional banks to expand their customer base outside their physical branches, giving them improved consumer access as well as the possibility for company expansion and customer acquisition. Second, the use of digital banking improves operational efficiency by automating manual procedures, streamlining processes, and lowering administrative expenditures, resulting in increased staff productivity and lower costs. Third, digital banking enables regional banks to innovate and develop new goods and services to meet changing consumer demands, such as digital payment services, online loans, and app-based financial services. This allows them to remain current and match their clients' tastes and expectations.

Finally, digital banking enhances the consumer experience by providing 24-hour availability, ease, and user-friendly interfaces, resulting in higher customer satisfaction. Regional banks may leverage on these opportunities to promote development, improve customer experiences, and remain competitive in the fast-changing financial world by embracing digital banking. It enables them to harness technology, extend their service offerings, reach a larger consumer base, and improve operational efficiency, resulting in greater success in the digital era.

CONCLUSION

This study investigated the adoption and use of digital banking technologies by Indonesian regional banks. It was discovered that Indonesian regional banks have prioritized collaborations with fintech firms as a main approach for adopting and implementing digital banking technologies. Mobile banking, for example, has significantly enhanced client convenience, operational efficiency, and market reach. However, adopting digital banking technology is not without obstacles such as a lack of technological infrastructure, security issues, and gaining client trust. More investment in technology, regulatory assistance, and consumer education is required to address these difficulties.

The findings highlight the relevance of digital banking in the banking industry, as well as its ability to generate growth and competitiveness for Indonesian regional banks. Regional banks may fully utilize the benefits of digital banking, build a more inclusive and lively banking system, and fulfill the increasing demands of clients in the digital era by adopting digital transformation, engaging with fintech companies, and dealing with the identified challenges.

The author believes that the originality of this research will be considered by regional banks when increasing the application of digital banking. This research will assist academics who will undertake relevant studies in the future. The authors strive to apply quantitative approaches and study other parts of the analytical process based on earlier research that focused on quantitative methods.

REFERENCE

- Akyuwen, Roberto., 2020. *Lebih Mengenal Digital banking, Manfaat, Peluang dan Tantangan*. Jakarta: Sekolah Pascasarjana Universitas Gadjah Mada.
- Kurniawan, A., Rahayu, A., & Wibowo, L. A. (2021). Pengaruh Transformasi Digital Terhadap Kinerja Bank Pembangunan Daerah Di Indonesia. *Jurnal Ilmu Keuangan Dan Perbankan (JIKA)*, 10(2), 158-181.
- Nilawati, F. E., Rizal, M., Rachmawanto, E. H., & Sari, C. A. (2019). Implementasi e-arsip untuk penyimpanan dokumen digital pada PT BPD Jateng (Bank Jateng). *Techno. Com*, 18(4), 299-311.
- Winasis, S., & Riyanto, S. (2020). Transformasi digital di industri perbankan indonesia: impak pada stress kerja karyawan. *IQTISHADIA Jurnal Ekonomi & Perbankan Syariah*, 7(1), 55-64.
- Akyuwen, R., & Mangowal, C. (2019). Leadership Challenges of Regional Banks in Indonesia. *KINERJA*, 23(1), 76-86.
- Akyuwen, R., Susilo, Y. S., & Kusumawijaya, R. (2019). COMPARATIVE FINANCIAL PERFORMANCE OF REGIONAL DEVELOPMENT BANKS (BPDS) AND THE BANKING INDUSTRY IN INDONESIA. *Journal of Applied Economics in Developing Countries*, 4(1), 1-10.



- Cahyono, E. F., & Laila, N. (2017). Financial efficiency of Islamic business unit at regional development banks in java island. *Advanced Science Letters*, 23(9), 8191-8196.
- Yusuf, M., Hartoyo, S., Manurung, A. H., & Temenggung, Y. A. (2017). Capital Investment Behavior of Local Government in Regional Development Bank (BPD) in Indonesia. *Jurnal Bina Praja: Journal of Home Affairs Governance*, 9(2), 281-293.
- Kamaludin, & Nashsyah, M. (2020). Modelling the competitiveness of regional bank: empirical evidence from Sumatera, Indonesia. *International Journal of Business and Globalisation*, 25(1), 23-45.
- Rachim, R., Riadi, S., Paminto, A., Defung, F., Suharto, R., & Setini, M. (2021). Financial services authority on profitability with external factors as moderating variables at regional development banks in Indonesia. *Accounting*, 7(6), 1445-1454.
- Jumono, S., Sugiyanto, S., & Mala, C. (2020). Mobilization of funds in Indonesian regional banking. *Management Science Letters*, 10(2), 295-302.
- Nidar, S. R., Anwar, M., Komara, R., & Layyinaturobaniyah, L. (2020). Determinant of regional development bank efficiency for their sustainability issues. *Entrepreneurship and Sustainability Issues*, 8(1), 1133.
- Karamoy, H., & Tulung, J. E. (2020). The impact of banking risk on regional development banks in Indonesia. *Banks and Bank Systems*, 15(2).
- Kalisman, J. H., Febrian, E., Afif, F., & Hasan, M. (2019). Transformation in business strategy: The key for bpd performance in indonesia. *Journal of Entrepreneurship Education*, 22, 1-9.
- Abidin, Z., Prabantarikso, R. M., Wardhani, R. A., & Endri, E. (2021). Analysis of bank efficiency between conventional banks and regional development banks in Indonesia. *The Journal of Asian Finance, Economics and Business*, 8(1), 741-750.
- Omarini, A. (2017). The digital transformation in banking and the role of FinTechs in the new financial intermediation scenario.
- Sundaram, N., Thomas, C., & Agilandeewari, L. (2019). A Review: Customers Online Security on Usage of Banking Technologies in Smartphones and Computers. *Pertanika Journal of Science & Technology*, 27(1).
- Rother, E. T. (2007). Systematic literature review X narrative review. *Acta paulista de enfermagem*, 20, v-vi.

CHAPTER 17

The Effect of Market Risk, Market Capitalization, Bond Rating, and Profitability on the Stock Return of Companies Listed in PEFINDO Investment Grade Index 2018 – 2022 with Company Age as The Moderating Variable

CHAIRINI

IPMI International Business School
chairini@ipmi.ac.id
Orcid: 0009-0006-5840-6953

Roy SEMBEL

IPMI International Business School
roy.sembel@ipmi.ac.id
Orcid: 0000-0002-9023-9976

Melinda MALAU

The Christian University of Indonesia
melinda.malau@uki.ac.id
Orcid: 0000-0002-6576-3063

ABSTRACT

Stock returns can be affected by numerous variables, ranging from economic indicators to company-specific factors. Understanding and analyzing these variables are crucial for investors, to make investment decisions and develop effective investment strategies. This study aims to analyze and evaluate variables affecting stock return on the constituents of PEFINDO Investment Grade Index in the period of 2018 – 2022 using variables of market risk, market capitalization, bond rating, profitability (return on asset), and the company's age as moderating variables. This study used a quantitative model approach with the type of explanatory research. The data source used is secondary data taken from quarterly reports of audited financial statements. The population of this study is 30 companies listed in PEFINDO Investment Grade Index in 2018 – 2022 with purposive sampling techniques of 11 companies that are consistently listed in PEFINDO i-Grade Index. The data technique analysis utilizes a panel data regression model to analyze the data. The results showed that market risk and return on asset (ROA) positively affect stock return while company age has a negative effect. Furthermore, other variables such as market capitalization and bond rating have no effect on stock return. On the other hand, Firm age can moderate the effect of market capitalization and market risk on the stock return, however; it cannot moderate the effect of bond rating, and profitability on the stock return of PEFINDO i-Grade Index.

Keywords: Market Risk, Market Capitalization, Bond Rating

1. INTRODUCTION

1.1 Background

Throughout 2022, the Indonesian capital market has recorded positive growth. According to data from the Indonesia Central Securities Depository (KSEI), the total number of investors in the Indonesian capital market rose by 37.7 percent to 10.3 million in December 2022, up from 7.48 million in 2021. Over the last three years, this figure has increased by more than fourfold. Additionally, the total number of stock investors and other securities has also increased by 28,64% to 4.43 million from 3.45 million in December 2022. (KSEI, 2022).

Figure -1.1: Total Number of Investors and Stock Investors in Indonesia Stock Exchange (IDX)

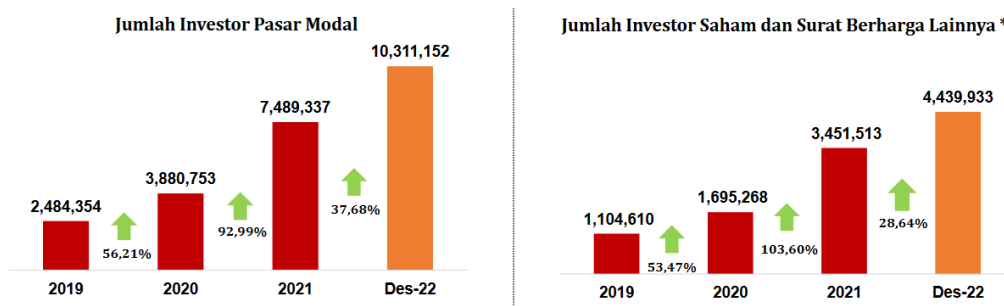

Source: KSEI Statistic, 2022

To make investment decisions easier for investors, the Indonesia Stock Exchange (IDX), provides a stock index that can be utilized by all stakeholders of the capital market. Currently, there are 42 indices listed in IDX, one of which is the PT Perneringkat Efek Indonesia (PEFINDO) Investment Grade Index (PEFINDO i-Grade). The PEFINDO i-Grade index is a stock index that measures the stock price performance of 30 stocks that issued bonds and obtain investment-grade ratings from PEFINDO.

This study chose the PEFINDO i-Grade as the research sample since the performance of PEFINDO i-Grade Index outperformed other stock indices such as the Jakarta Composite Index (JCI), LQ45, IDX30, and SRI-KEHATI index, as shown in Figure 1.2

Figure - 1.2: Performance Comparison of JCI, LQ45, IDX30, SRI KEHATI, and PEFINDO i-Grade

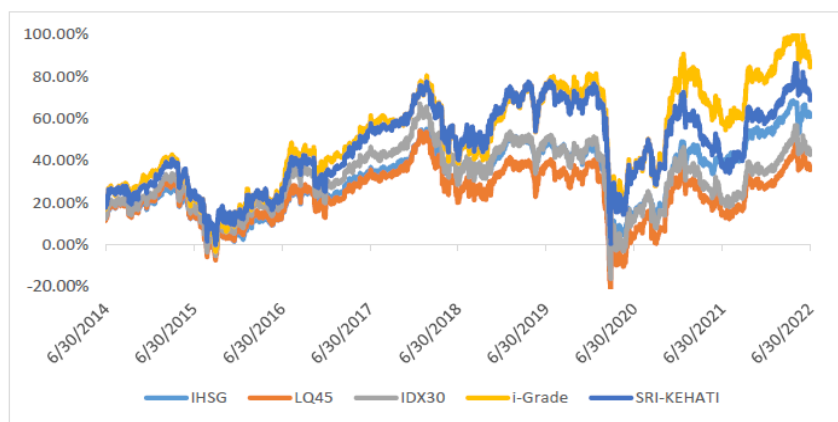

*As of June 30, 2022
Source: PEFINDO database, IDX, and Bloomberg. Processed by PEFINDO (2022)

Source: PEFINDO Press Release, 2022

Moreover, the main goal for investors investing their funds in the capital market is to get a return on their investment. Return refers to the financial gain on investment returns (Abbas et al, 2022). Numerous factors might have an impact on stock returns. The author will focus on independent variables such as Market Risk, market capitalization, bond ratings, and profitability to test their impact on stock return as the dependent variable while company age will be used as the moderating variable.

1.2 Research Problem

Previous research that has been conducted by other researchers has shown different results (research gap) regarding the effect of market risk, market capitalization, bond rating, and profitability on stock returns. Therefore, this study intends to fill the gap by adding moderating variables of company age to test the impact of those variables on stock return.

1.3 Research Question

Based on the background and research problem above, the research questions of this study are as follows:

1. How does market risk affect stock return?
2. How does market capitalization affect stock return?
3. How does bond rating affect stock return?
4. How does profitability affect stock return?
5. How does company age affect stock return?
6. How does company age moderate the effect of market risk on stock return?
7. How does company age moderate the effect of market capitalization on stock return?
8. How does company age moderate the effect of bond rating on stock return?
9. How does company age moderate the effect of profitability on stock return?

2. LITERATURE REVIEW

2.1 Signaling Theory

The basic theory used to explain this study is the signaling theory. Hartono (2017) put forward this theory, stating that the information obtained is an announcement and will signal investors to make investment decisions. If the information presented contains a positive value, it is hoped that the market will respond to the information. Information received by market players will first be analyzed and will be interpreted as a positive signal (good news) or a negative signal (bad news).

2.2 Capital Asset Pricing Models (CAPM)

The measurement tool used to determine the level of risk and return that can be obtained is the Capital Asset Pricing Model (CAPM). CAPM was originally developed by Sharpe (1964) and Lintner (1965). This method links the expected return with a measure of systematic risk. CAPM provides a methodology for quantifying risk and translating it into expected return on equity (ROE).

2.3 Markowitz Portfolio Theory

Markowitz's Portfolio Theory focuses on the connection between risk and returns in a portfolio of assets. This theory emphasizes the value of diversification and takes into account the risk-return trade-off while building investment portfolios. It has evolved into a principle of

contemporary portfolio management and influenced the way investors think about asset allocation and risk management.

2.4 Efficient Market Hypothesis

The Efficient Market Hypothesis (EMH) was first introduced and developed by economist Eugene Fama in the 1960s and 1970s. This theory suggests that financial markets are efficient and that it is not possible for investors to consistently achieve above-average returns by using publicly available information. According to EMH, financial markets incorporate and reflect all relevant data about the value of an asset, and prices quickly adjust to new information as it becomes available. Accordingly, it is impossible for investors to consistently outperform the market by taking advantage of securities that have been mispriced, as any pricing abnormalities would be immediately fixed.

2.5 Research Framework and Hypotheses

Based on the description of the theory used in this study, the model framework of this study as shown in Figure 2.1

Figure 2-1: Research Framework

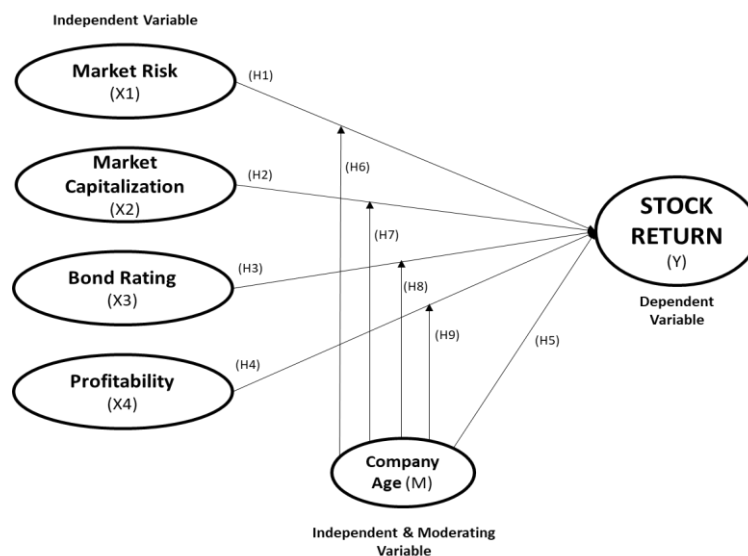

Source: Author, 2023

3. METHODOLOGY

3.1 Research Method

The type of this study is quantitative research with the model of explanatory research to identify the causes and effects of the phenomenon being studied by collecting and analyzing numerical data. The data source used is secondary data from quarterly financial reports of the publicly listed companies of PEFINDO i-Grade Index for the period of 2018 to 2022.

Stock price data were taken from Yahoo Finance, Bloomberg, and Bond Rating data were taken from the PEFINDO website. In this study, the sample used is non-probability sampling

with a sample using purposive sampling. The research population is 30 public companies listed in PEFINDO i-Grade Index from 2018 to 2022, while the sample is 11 companies that are consistently listed in the Index during the observation period, as shown in Table 3.1

Table – 3.1: Research Sample

No.	Company	Ticker
1	Telekomunikasi Indonesia (Persero) Tbk.	TLKM
2	Bank Rakyat Indonesia (Persero) Tbk.	BBRI
3	Bank Mandiri (Persero) Tbk.	BMRI
4	Bank Negara Indonesia (Persero) Tbk.	BBNI
5	Semen Indonesia (Persero) Tbk.	SMGR
6	Mayora Indah Tbk.	MYOR
7	Jasa Marga (Persero) Tbk.	JSMR
8	Indosat Tbk.	ISAT
9	Bumi Serpong Damai Tbk.	BSDE
10	Pembangunan Perumahan (Persero) Tbk	PTPP
11	Medco Energi Internasional Tbk.	MEDC

Source: Author, 2023

This study used a panel data regression analysis model as a data analysis technique with the equation as follows:

$$Y_{it} = \alpha + \beta_1 X_{1t} + \beta_2 X_{2t} + \beta_3 X_{3t} + \beta_4 X_{4it} + \beta_5 D_t + \beta_6 X_{1t} * D_t + \beta_7 X_{2t} * D_t + \beta_8 X_{3t} * D_t + \beta_9 X_{4t} * D_t + \epsilon_{it}$$

where :

- Y_{it} = Stock Returns of the company i at period t
- X_{1t} = Market risk of the company i at period t
- X_{2t} = Market capitalization of the company i at period t
- X_{3t} = Bond rating of the company i at period t
- X_{4it} = Profitability of the company i at period t
- D_t = Company age at period t
- α = the intercept of the regression model
- β = the slope coefficient
- ϵ_{it} = the error component of the observed cross-sectional units and period

CONCLUSION

Based on the hypothesis testing of variables mentioned above, the study found that:

1. Market risk has a positive effect on stock return
2. Market capitalization has no effect on stock return
3. Bond rating has no effect on stock return
4. Profitability ratio measured by return on asset (ROA) has a positive effect on stock return
5. The company's age has a negative effect on stock return
6. The company's age can moderate the effect of market risk on stock return
7. The company's age can moderate the effect of market capitalization on stock return



8. The company's age can moderate the effect of bond rating on stock return
9. The company's age cannot moderate the effect of profitability (return on asset) on stock return

REFERENCES

- Abbas, D.S., Zulaecha, H.E., Rachmania, D., Hakim, M.Z., & Rachmi, D.A. (2022). Analysis of Determinant Factors in Influencing Stock Return: Panel Data Analysis Approach. *Daengku: Journal of Humanities and Social Sciences Innovation*, 2(5), 645-655.
- Halim, B., Sembel, R., & Malau, M. (2022). Financial Performance Analysis And The Effect Of Profitability And Market Return On The Stock Return Of PT. Adaro Energy Indonesia Tbk-A Coal Mining Company In Indonesia. *International CEO Communication, Economics, Organization & Social Sciences Congress*, 994-1012.
- Kurniawan, A. (2021). Analysis of the Effect of Return on Asset, Debt to Equity Ratio, and Total Asset Turnover on Share Return. *Journal of Industrial Engineering & Management Research*, 2(1), 64-72.
- Kurniawati, D. H., Sembel, R., & Malau, M. (2022). Stock Performance and Analysis of Market Capitalization and Fundamental Factors of Socially Responsible Companies in Indonesia on Stock Return: A Study of SRI KEHATI Index. *International CEO Communication, Economics, Organization & Social Sciences Congress*, 1404-1417.
- Gujarati, D.N. (2016). *Dasar-Dasar Ekonometrika. Buku II. Edisi. Kelima*. Jakarta Selatan: Salemba Empat.
- Hartono, J. (2017). *Teori Portofolio dan Analisis Investasi, Edisi Kesebelas*. Yogyakarta : BPFE.
- Hery. (2015). *Analisis Kinerja Manajemen*. Jakarta: Penerbit PT. Grasindo.
- Jogiyanto, H. (2017). *Metode Penelitian Bisnis. Edisi Ke-6*. Yogyakarta : Universitas Gadjah Mada.
- Kasmir. (2016). *Analisis Laporan Keuangan*. Jakarta: Raja Grafindo Persada.
- Kothari, C.R. (2004). *Research Methodology: Methods And Techniques (2nd Revised Edition)*. New Delhi: New Age International (P) Limited, Publishers.
- Malhotra, N.K. (2018). *Marketing Research: An Applied Orientation*. New Jersey : Prentice Hall.
- Markowitz, H. (1959). *Portfolio Selection: Efficient Diversification of Investments*. New York: Wiley (2nd Ed.) Cambridge, MA: Basil Blackwell.
- Nachrowi, D.N., & Usman, H. (2016). *Pendekatan Populer dan Praktis Ekonometrika untuk Analisis Ekonomi dan Keuangan*. Jakarta: Badan Penerbit Universitas Indonesia.
- Sekaran, U., & Bougie, R. (2017). *Metode Penelitian untuk Bisnis: Pendekatan Pengembangan-Keahlian, Edisi 6, Buku 1, Cetakan Kedua*. Jakarta Selatan: Salemba Empat.
- Tandelin, E. (2017). *Analisis Investasi dan Manajemen Portofolio*. Yogyakarta: Kanisius.
- Snedecor, G.W., & Cochran, W.G. (1989). *Statistical Methods*, Eighth Edition. Iowa State : University Press.

CHAPTER 18

Fairness in Obtaining Repurchase Intention Through Goal Achievement

Karunia Fransiska

Master of Management, Faculty of Economy, and Business
Universitas Trisakti

Yolanda Masnita

Master of Management, Faculty of Economy, and Business
Universitas Trisakti
yolandamasnita@trisakti.ac.id
Orcid: <https://orcid.org/0000-0002-5758-8146>

***Kurniawati**

Master of Management, Faculty of Economy, and Business
Universitas Trisakti
kurniawati@trisakti.ac.id
Orcid: <https://orcid.org/0000-0002-4339-0278>

Renny Rizqiani

Master of Management, Faculty of Economy, and Business
Universitas Trisakti

ABSTRACT

The fashion industry is a significant aspect of modern life, with shoes being a crucial component of fashion trends and daily activities such as work, school, and sports. Indonesia's shoe industry has a 4.5% share of the global market and is the fourth-largest shoe producer worldwide. To compete effectively, shoe producers require an effective plan. A survey was conducted in Indonesia to gather information about shoe buyers. The results of the survey indicated that customer perceptions of fairness increase when they have a positive shopping experience with discounts. Customers will try to obtain discounts on exclusive shoe brands by waiting in line for hours. The impact of consumers' awareness of discounted shoe products on fairness was not significant because there was no evidence to support the effect of knowledge on fairness. The demographic results of the respondents were mainly millennials, who tend to be close to technology and shopping and go through a lengthy process when they shop online. The study's findings are essential for marketing managers in the shoe industry, who can use the information to create product promotion policies that influence repurchase intent among consumers. Positive and significant effects were found for purchase decisions and advertising engagement for discount customers, which are the primary driving force behind the experience. Fashion retailers must provide unique experiences and merchandising practices to differentiate themselves from rivals, target discount shoppers, and expand globally.

Keywords: Retail, discount, Overall Satisfaction, Fairness, Repurchase Intention, Achievement Goal Theory

INTRODUCTION

Fashion is an essential requirement for people in today's world. Every year, fashion trends drive the growth of models, brands, and shoe types (Yoon Kin Tong et al., 2012). Shoes are fashion icons that meet the requirements for some activities like work, school, and sports (Sari & Alexander, 2021). The shoe industry in Indonesia stands to benefit greatly from this opportunity. However, to compete effectively in the market, producers need an effective plan. With a share of 4.5%, Indonesia is the fourth-largest footwear consumer in the world and the fourth-largest shoe producer worldwide (Liputan6.com, 2020). In the meantime, Indonesia ranked third in footwear exports in 2019 after a number of countries around the world were affected by the coronavirus outbreak. The "Asia Pacific Health Inertia Survey 2021" survey, which was conducted in 11 countries in the Asia-Pacific region, including Indonesia, found that the COVID-19 pandemic has increased public awareness of the significance of regular exercise and a healthy lifestyle (Nutrition, 2021).

Table 1. Financial Highlight MAP

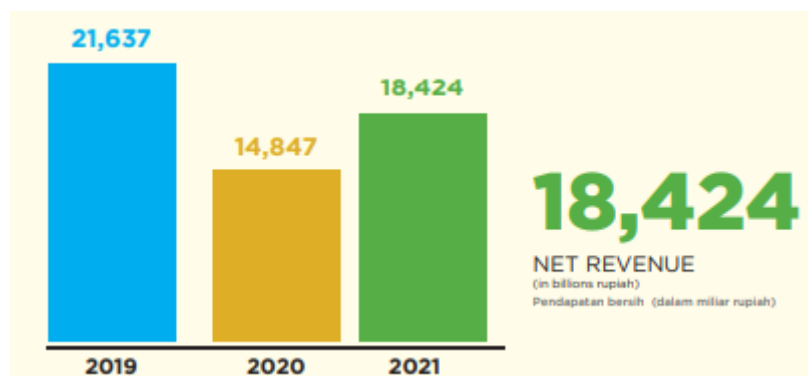

Source : <https://www.map.co.id/investor/details/>

According to table 1, the Indonesian shoe industry saw fluctuations in sales between 2019 and 2021. This suggests that consumers' interest in making purchases is still relatively low. This demonstrates that the Indonesian shoe industry still has the potential to increase revenue in 2022, provided, of course, that marketing strategies are implemented that focus on aspects of customer satisfaction that can affect repurchase intention (Akhter et al., 2014).

Kotler and Keller (2007) Price is very important in product marketing because it is the only part of the marketing mix that makes money for a business or organization. Pricing has a significant impact on a business's ability to influence customers and remain competitive (Rifai, 2021). The retail sector frequently makes use of discounts to entice customers (Shehryar & Hunt, 2005). When the word "discount" is mentioned, people are more likely to be interested in purchasing a product because they get the impression that it is cheap . One of the pricing strategies that can be used to influence consumer choice is a discount program that is also expected to benefit the business. One of the most important factors that can affect the

demand and supply of a company's products is product modification through price changes. Businesses can now measure how much price changes can affect supply and demand thanks to this (Fadillah & Rini, 2013).

Achievement Goal Theory (Nicholls, 1992) has been used in the literature on management, sport psychology, and education (Duda & Nicholls, 1992). This theory has been used in previous studies to explain how the level of discount consumer engagement affects the shopping experience, overall satisfaction, and intentions to repurchase (Mortimer et al., 2022). According to research, discount shoppers perceive the discount shopping experience as a competitive activity that boosts their self-esteem when they believe they have outperformed other shoppers to obtain products at very low prices (Herrmann et al., 2007). Customers spend a lot of time, effort, and expertise when they shop, according to the same studies; It has been demonstrated that consumer engagement affect attitudinal and behavioural outcomes like how much information is processed and how often people search for things. Therefore, discount customers' level of engagement may have an impact not only on their level of effort and mastery but also on their sense of pride and their desire to impart knowledge. Additionally, prior research has focused on the outcome of the shopping experience, i.e. purchase intention, rather than the level of engagement, which may have an impact on the shopping experience (Kumar et al., 2018). In the meantime, (Devica, 2015) study found that discounts can encourage customers to make irrational purchases and enjoy shopping. Through the mediation of fairness, the purpose of this study is to investigate the effects of effort, pride, knowledge, overall satisfaction, and repurchase intentions. where a marketing manager can reference or base decisions regarding the company's fairness and overall customer satisfaction on the findings of this study. Additionally, this study may serve as a theoretical foundation for subsequent research on the same subject.

1. LITERATURE REVIEW

Achievement Goal Theory

According to Nicholls (1992), The academic, sports psychology and management literature have all made use of goal attainment theory. It explains how the conditions of this study influence the relationship between goals and objectives (Duda & Nicholls, 1992). Roberts and others (1995), according to goal attainment theory, Celsi and Olson (1988) state that a person's level of involvement can influence their consumption experience, level of satisfaction, and repeat behavior (Lumpkin & Florida, 2009). Managers ought to be aware that setting appropriate goals is one of the factors that drive sales force motivation, as defined by Kelley & Caplan (1992). Goals keep employees motivated, happy, and productive, but managers might find it hard to set the right goals (Kumar et al., 2018). As previous research has demonstrated, the achievement goal theory describes how an individual's level of engagement can influence the consumption experience, level of satisfaction, and repeat behaviour of consumers (Mortimer et al., 2022)



Effort , Pride and Knowledge

Discount shoppers pursue products and brands with determination, effort, and task focus as a result of the behaviour described earlier, demonstrating highly developed skills and effort (Mortimer et al., 2022). The desire to locate the desired product grows with confidence in the discount shopper task. As a result, customers are more satisfied with their shopping experience (Barling & Beattie, 1983). Additionally, discounted customers are extremely proud of their accomplishments (Mortimer et al., 2022). The connection between discount shoppers' overall satisfaction while shopping and their pride in accomplishing their objectives is explained by social cognitive theory. According to the theory, a person's current performance is compared to their goal. The criteria they set for themselves and the significance of the objective then have an impact on their level of contentment (Zimmerman & Schunk, 2001). Recent studies indicate that customers who act socially responsible and offer advice to others feel proud (Duda & Nicholls, 1992). This relationship is supported by the findings regarding discount customers. Consequently, discount customers will experience greater overall contentment when they take pride in achieving objectives they hold dear. Social approval-oriented goals are achieved when the discount shopper is recognized for their expertise (Mortimer et al., 2022).

Fairness

The concept of fairness is based on the theory of justice, which is adapted from the theory of equality (Giovanis et al., 2015). When we talk about service fairness, we mean the customer's perception of the degree of fairness in the service provider's behaviour (Guchait et al., 2011). When customers' experiences are compared to their standards of fairness and they identify that they are treated fairly or unfairly, their assessment of service fairness will emerge. To feel satisfied in a relationship, people seek a fair ratio between inputs and outputs. While perceptions of fairness lead to positive feelings and satisfaction, perceptions of unfairness lead to dissatisfaction. On the other hand, companies will find it difficult to gain customer trust and loyalty if they cannot project an image of fairness. Interactional justice includes politeness or interpersonal fairness, respect, consideration shown during transactions, and the quantity and quality of customer-service provider communication. Interactional justice has the greatest impact on customer satisfaction and trust in service providers of the three types of justice (Herrmann et al., 2007).

Effort & Fairness

According to a number of studies using various price promotion strategies, customers' perception of price fairness when they reject the promoted price is negatively affected by the amount of effort they believe is required to obtain the lower price (Kukar-Kinney et al., 2011). However, the less promotion and price fairness, the more people believe that the effort they put into the purchase will be wasted (Xia et al., 2010). In the context of price promotion, this study investigates how consumer effort as a nonmonetary sacrifice affects consumers' perceptions of price fairness and promotion. According to research, Customer effort is more important than price adjustments made by retailers. Customers can be persuaded and

provoked by incentives. Rewards that match the promoted consumption effort are suggested as a way to reassert consumer autonomy (Herrmann et al., 2007). This gives credence to this idea:

H1 The effort has a positive impact on Fairness

Pride and Fairness

Perceived control and fairness have been shown to positively impact consumer satisfaction and behavior intentions in a number of studies (Guchait et al., 2011). As significant antecedents of consumer satisfaction and behavioural intentions, the majority of researchers have examined fairness and control. However, aside from studies on service failure and recovery, research on the antecedents of control and fairness has received little attention (Giovanis et al., 2015). This study reveals that service providers' knowledge management practices have a significant impact on customers' perceptions of control and fairness. Additionally, when consumers perceive fairness and high levels of control in service exchanges, they are more likely to rate services positively (Amos et al., 2008). Therefore, it is thought that:

H2 Pride has a positive impact on Fairness

Knowledge & Fairness

"Discount" customers pursue products and brands with determination, effort, and task focus as a result of the previously mentioned discount shopper behaviour, demonstrating highly developed skills and mastery. The desire to locate the desired product grows with confidence in the discount shopper task. As a result, customers are more satisfied with their shopping experience. In addition, discount customers take genuine pride in completing tasks successful (Mortimer et al., 2022). The connection between discount shoppers' overall satisfaction while shopping and their pride in accomplishing their objectives is explained by social cognitive theory. People compare their current performance to their desired outcomes, according to the theory. The standards they set for themselves and the significance of the goal then have an impact on their level of contentment (Herrmann et al., 2007). Recent studies indicate that customers who act socially responsible and offer advice to others feel proud (Giovanis et al., 2015). This connection is supported by the findings regarding customers who take advantage of discounts; Discount customers will be happier overall if they take pride in achieving goals they hold dear. Last but not least, people who buy cheap shoes think they know a lot about the footwear industry and its goals. They share their knowledge and strategies with the group in order to gain social approval because they want to be seen as an authority. When a discount customer achieves social validation from others by recognizing their expertise, social approval-oriented goals are achieved (Mortimer et al., 2022). Therefore, it is thought that:

H3 Knowledge has a positive impact on Fairness



Fairness and Overall Satisfaction

The factors that increase customer satisfaction in various contexts have been examined in previous customer satisfaction research (Giovanis et al., 2015). The role of product or service prices in determining customer satisfaction has not been extensively studied in prior customer satisfaction research, despite its importance in the marketing mix (Herrmann et al., 2007). One of the few aspects of the product that are deemed important when price is included (Devica, 2015) ; However, it is still unclear how product price affects ratings of satisfaction. We include consumers' perceptions of prices as a significant determinant of overall satisfaction ratings in this study. Through the perception of price fairness, this influence is both direct and indirect argue that the relationship between satisfaction and expectations is weak and that price, satisfaction, and expectations are all linked to satisfaction. They argue that perceived price fairness may be the most important factor in customer satisfaction, in contrast to performance. According to their empirical findings, ratings of satisfaction suffer more severely when perceived price performance is inconsistent. Oliver and DeSarbo also discovered results that were similar Oliver and DeSarbo (1988) , Oliver and Swan (1989a). Equity is also linked to happiness, according to research. The judgment of fairness, rightness, or appropriateness that consumers make when comparing others is commonly used to define equity, a concept that is closely related to fairness (Herrmann et al., 2007).

H4 Fairness has a positive impact on Overall Satisfaction

Overall Satisfaction and Repurchase Intention

A customer who plans to buy a product again is open to doing so in the future. (Budiarti, 2020) defines consumer intention to repurchase an item they have purchased. Consumers' desire to buy or not buy a product is known as repurchase intention (Devica, 2015). Repurchase intention and the reasons he has for using or purchasing a particular product are closely linked throughout the buying process. This purchase is made by each customer for various reasons. Repurchase intention, as mentioned earlier, is the consumer's decision to make the first purchase and positive attitude toward future purchases. According to Kotler (2009) Consumer satisfaction refers to a person's feelings of pleasure or disappointment after comparing his perceptions or impressions of performance that are not in accordance with expectations (Budiarti, 2020). Customers, on the other hand, are very happy when performance meets or exceeds expectations. If the perceived performance does not match expectations, the customer will be dissatisfied; if the performance meets expectations, the customer will be very satisfied. Hansemark & Albinsson (2004) say that the overall level of customer satisfaction reveals how they feel about the service provider or when they do not get what they expect (Guchait et al., 2011). In contrast, Bitner & Zeithaml (2003) define customer satisfaction as the extent to which a product or service meets customer needs and expectations. Zeithaml (1996) asserts that price fairness is a factor that directly affects consumer loyalty and sensitivity to price. A fair price motivates customers to recommend it to others. Price fairness, as defined by Gilbert (2003), is the monetary value placed by the seller on something bought, sold, or offered for sale, as well as the value placed by the buyer on the

transaction because customers are willing to pay for the benefits of products and services. This definition clearly identifies how to treat price as a cash flow or revenue-generating function from the consumer's point of view, which views price as more than just money. Consumers' perception of value is complex as they derive various emotional and practical benefits from products and brands when they shop (Guchait et al., 2011).

H5 Overall Satisfaction has a positive impact on repurchase Intention

2. METHODOLOGY

Collection of Data

An online survey was used to collect information about shoe buyers in Indonesia for this study. Customers who had made at least two purchases in the previous six months and were interested in using a discount program to make additional purchases were the focus of the study. A group of customers were recruited for the survey by our Indonesian research team. Participants were given an overview of the study as well as definitions of key terms like fairness and overall satisfaction. After that, participants talked about the kinds of shoes that they had bought in the past six months. At this point, participants who had not purchased the product at least once in the preceding six months were excluded from the survey. 280 valid responses were gathered for the purpose of data analysis.

Measurement

There were five sections to the survey questionnaire, each with a set of questions intended to evaluate the research variables: 1) Information about a person's demographics; 2) how the customer perceives effort, pride, and knowledge; and 3) how the customer perceives fairness. 4) The perception of overall satisfaction and (5) the intention to repurchase by the customer. All of the measures were adapted from existing scales, and previous research confirmed their reliability and validity.

3. RESULT

Characteristics of the Sample

The majority of respondents are female, with 56.4% being between the ages of 31 and 35. Employees who earn more than IDR 10,000,000 per month (56.8%) are the respondents implying that they hold middle- to upper-level managerial positions. Over a one-year period, 70% are most likely to purchase shoes 2-4 times in the last 1-4 months.

Data Analytics

Table-1: Validity & Reliability

Variable	Loading Factors	Cronbach α
Effort		0,842
Try your best to score deals on exclusive shoe brands.	0,666	
Willing to queue for hours.	0,736	
I have experience in hunting for heavy	0,816	



discounted products. When I commit to finding discounted shoes, I will do my best.	0,839	
Pride I'm happy when I find a high-end shoe product at a very low price. Feeling the "thrill of victory" every time I find designer brand shoes at a cheaper price. It feels like a great win when you find shoes at a significantly reduced price.	0,918 0,929 0,832	0,921
Knowledge I'm well-versed in the process of finding low-cost exclusive shoe brands. I know where to look for designer shoe brands at very low prices. I know where to go to get great prices on well-known shoe brands. I was asked by friends where I could buy discounted exclusive shoe brands. When it comes to sought-after shoe brands, I know precisely when to shop. I excel at finding well-known shoe brands at extremely low prices.	0,788 0,922 0,877 0,831 0,797 0,887	0,940
Fairness In general, I think the discount is fair. I'm happy with how this discount works. The discount will reflect the shoe's high quality. Discounts will lead to a fair outcome.	0,886 0,800 0,755 0,800	0,915
Overall Satisfaction Discounts will enable brands to meet my requirements. I'm pleased with my decision to save money on high-quality footwear.	0,843 0,843	0,932

Accounting Inquiries with New Approaches in the Post-Pandemic Era
Volume I

Brands will be able to meet my need with discounts.	0,860	
Buying a shoe brand at a lower price a good experience.	0,844	
I was pleased with my decision purchase discounted footwear.	0,892	
When I go shopping again, I will buy the same pair of shoes again.	0,624	
Repurchase Intention		0,912
Buying a shoe brand at a discount will satisfy my future shopping requirements	0,880	
I'll think about buying more discounted shoe brands in the future.	0,861	
As a result, you're anxious to avoid being distracted by the discount.	0,870	
Will look for significant savings the next time I shop for shoes.	0,871	

Data analysis was provided in two phases (Hair et al., 2010). To begin, confirmatory factor analysis (CFA) was conducted to guarantee the proposed measurement model's high quality. Second, the proposed hypotheses were tested using structural equation modelling. proposed theories The covariance matrix was estimated using maximum likelihood in both analyses that were carried out with Amos 23.0. The measurement model's suitability was assessed using construct reliability, convergent validity, discriminant validity, and Cronbach's alpha. Common internal consistency indices are construct reliability and Cronbach's alpha. The measurement model's factors were all utilized by the CFA.

Table-2: Goodness of Fit

Goodness of Fit Index	Criteria	Value	Conclusions
Chisquare	Small Chi-square	1304,89	Poor
p-value Chisquare	$\geq 0,05$	0,000	Poor
RMSEA	≤ 0.10	0,100	Good
RMR	≤ 0.10	0,153	Poor
GFI	≥ 0.90	0,745	Poor
NFI	≥ 0.90	0,832	Marginal
TLI	≥ 0.90	0,856	Marginal
RFI	≥ 0.90	0,815	Marginal
CFI	≥ 0.90	0,870	Marginal
AGFI	≥ 0.90	0,698	Poor
CMIN/DF	Lower limit: 1.0 Upper limit: 2.0; 3	3,815	Good

The proposed hypotheses were tested using structural equation modelling. The outcomes demonstrated an adequate model fit ($\chi^2 = 1304.89$, $df = 3,815$, $\chi^2/df = 5.06$, $CFI=0.870$, $TLI = 0.856$, $IFI = 0.870$, $RMSEA = 0.14$, $RMR \leq .10$), The results are presented in 2nd table.

Figure 1 Generated Research Model

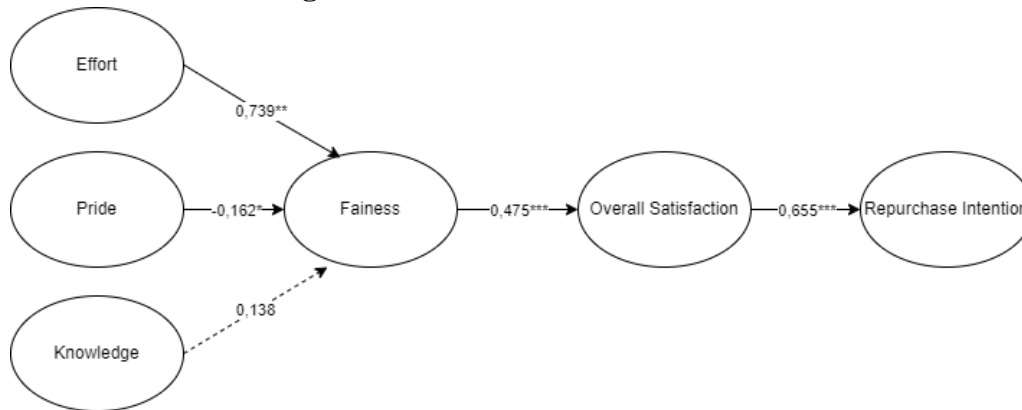

Note: * $p < 0.05$, ** $p < 0.01$, *** $p < 0.0001$ - - - - Insignificant

Direct Hypothesis

The effects of effort, pride, and knowledge on fairness were predicted by hypotheses 1 through 3. The analysis revealed that Effort ($\beta = 0,739$, $P < 0.05$), Pride ($\beta = -0.162$, $P < 0.001$), Knowledge ($\beta = 0.138$, $P < 0.05$) significant contribution to fairness. The results indicate that Fairness has a positive and significant effect on Repurchase Intention, which is consistent with Hypothesis 4, which predicts the effect of Fairness on Overall Satisfaction ($\beta = 0,655$ $P < 0,001$). As a result, H1, H2, H3, and H4 receive support. Table 3 provides an overview of direct hypothesis testing.

Table-3: Structural Model Results

Hypothesis	Standardized Estimates	Profitability	Conclusion
H1 : Effort>Fairness	0,739	0,005	Accepted
H2 : Pride>Fairness	-0,162	0,034	Accepted
H3 : Knowledge>Fairness	0,138	0,510	Rejected
H4 : Fairness > Overall Satisfaction	0,475	0,000	Accepted
H5 : Overall Satisfaction > Repurchase Intention	0,655	0,000	Accepted

Note : $p < 0.05$ conclusion is accepted, but by $p > 0.05$, conclusion is rejected.

The P-value of 0.739 and Estimate of 0.005 exhibited that the results support the impact of effort on fairness; so that customers' perceptions of fairness will rise when they have a positive shopping experience for discounts. By waiting in line for hours, customers will try to get discounts on exclusive shoe brands. Customers will try their hardest when they are committed to finding discounted shoe products in every massive discount product hunting experience. In the meantime, consumers' awareness of discounted shoe products will not have a significant impact on fairness in their minds because there is no evidence to support the effect of knowledge on fairness. This is because the demographic results of the respondents are dominated by millennials, who also tend to be close to technology and shopping. Millennials also go through a lengthy process when they shop online, beginning with conversation and trend analysis before making a purchase decision (Kahfi Dirga Cahya, 2018).

Discussion

Studies that only focus on fairness and Achievement Goal Theory A number of recent studies show that Achievement Goal Theory has a big effect on repurchase intention. This study specifically addresses the role of Achievement Goal Theory by using effort, pride, knowledge, and fairness as intermediate variables. This study also demonstrates that fairness acts as a mediator, influencing consumers' perspectives on repurchase intention.

4. IMPLICATION

Theoretical implications

Numerous significant contributions to our understanding are made by this study. First, it uses Achievement Goal Theory to determine whether shoe retailers' discount programs meet customer expectations (Duda & Nicholls, 1992). Second, this study shows that fairness acts as a middleman between products and customers. Lastly, the previous journal's study of the shopping experience looked at the discount shopping habits of two different kinds of customers from two very different cultural backgrounds. It found that shopping habits in both markets went beyond price, making the findings more reliable and capable of explaining things. The reliability and efficacy of these findings as explanations (Mortimer et al., 2022).

Limitations and future research

This study, like all others, has limitations that point to potential areas for additional research. A large-scale survey that measures the "discount" shopper experience over a long period of time might be part of future research. Second, the fashion of shoes was the setting for this study. Discounters, on the other hand, might also be active in travel, home appliances, consumer electronics, sporting goods, and other product and service categories. The antecedents included in this study may have an impact on discount shopping behaviour in these categories, which could be the subject of future research. Thirdly, this study did not focus on online discount shopping. Fourthly, the study found that discount shopping appears



to be driven by consumers' need to conduct extensive research before making a purchase, indicating a risk-averse mindset. Avoi & Ce and future risk tolerance studies may yield useful findings. Finally, the three types of consumer involvement examined in this study are advertising involvement, product involvement, and purchase decision involvement. Other psychological constructs may also be investigated as antecedents associated with the discount shopping experience in future research. As discount retail continues to evolve into a significant and distinct retail format, it is important for retail managers and marketing academics to have an understanding of the shopping habits of discount shoppers.

REFERENCES

- Akhter, S., Rizwan, M., & Manajemen, J. I. (2014). Dampak kegiatan promosi penjualan sepatu retail pada niat pembelian wanita. 2, 166–178.
- Amos, C., Holmes, G., & Strutton, D. (2008). Exploring the relationship between celebrity endorser effects and advertising effectiveness: A quantitative synthesis of effect size. *International Journal of Advertising*, 27(2), 209–234. <https://doi.org/10.1080/02650487.2008.11073052>
- Budiarti, novi yulia. (2020). Pricing. *Sustainability (Switzerland)*, 4(1), 1–9.
- Devica, S. (2015). Pengaruh Harga Diskon Dan Persepsi Produk Terhadap Nilai Belanja. In *Appl. Phys. A (Vol. 73)*.
- Duda, J. L., & Nicholls, J. G. (1992). Dimensions of Achievement Motivation in Schoolwork and Sport. *Journal of Educational Psychology*, 84(3), 290–299. <https://doi.org/10.1037/0022-0663.84.3.290>
- Fadillah, A., & Syarif, R. (2013). Pengaruh Program Diskon Terhadap Keputusan Pembelian. In *Jurnal Ilmiah Manajemen Kesatuan (Vol. 1, Issue 1)*. <https://doi.org/10.37641/jimkes.v1i1.256>
- Giovanis, A., Athanasopoulou, P., & Tsoukatos, E. (2015). The role of service fairness in the service quality – relationship quality – customer loyalty chain: An empirical study. *Journal of Service Theory and Practice*, 25(6), 744–776. <https://doi.org/10.1108/JSTP-11-2013-0263>
- Guchait, P., Namasivayam, K., & Lei, P. W. (2011). Knowledge management in service encounters: Impact on customers' satisfaction evaluations. *Journal of Knowledge Management*, 15(3), 513–527. <https://doi.org/10.1108/13673271111137466>
- Herrmann, A., Xia, L., Kent, M. B., & Huber, F. (2007). The influence of price fairness on customer satisfaction: An empirical test in the context of automobile purchases. *Journal of Product and Brand Management*, 16(1), 49–58. <https://doi.org/10.1108/10610420710731151>
- Kahfi Dirga Cahya. (2018). Bagaimana Generasi Milenial Berbelanja Online? Merdeka.Com.
- Kukar-Kinney, M., Xia, L., & B. Monroe, K. (2011). When a promotion is denied: the effects of decision stage on perceptions of promotion and price fairness. *Economic and Business Review*, 13(3). <https://doi.org/10.15458/2335-4216.1237>
- Kumar, V., Goreczny, A., & Maurer, T. (2018). What drives a salesperson's goal achievement? An empirical examination. *Journal of Business and Industrial Marketing*, 33(1), 3–18. <https://doi.org/10.1108/JBIM-06-2017-0128>
- Liputan6.com. (2020). Jadi Negara Produsen Terbesar Keempat, Industri Sepatu Indonesia Kian Menggeliat. November, 12, 2020.
- Lumpkin, R. B., & Florida, A. (2009). School Buildings, Socioeconomic Status, Race, and Student Achievement. 2006, 170–186.
- Mortimer, G., Grimmer, M., Grimmer, L., Wang, S., & Su, J. (2022). A cross cultural examination of “off-price” fashion shopping. *International Journal of Retail and Distribution Management*, 50(12), 1494–1517. <https://doi.org/10.1108/IJRDM-09-2021-0457>
- Nutrition, H. (2021). Sebanyak 63% Konsumen di Indonesia Menganggap Kesehatan Mereka Kurang Ideal.
- Rifai, A. (2021). Pengaruh Harga Dan Diskon Terhadap Keputusan Pembelian Konsumen Pt Utama Sejuk Abadi. Neliti.Com.
- Sari, M. W., & Alexander, O. (2021). Sistem Pendukung Keputusan Pemilihan Sepatu Pada Online Shop Choice Fashion Dengan Menggunakan Metode Moora. DoubleClick: *Journal of Computer and Information Technology*, 5(1), 43. <https://doi.org/10.25273/doubleclick.v5i1.10038>

Accounting Inquiries with New Approaches in the Post-Pandemic Era
Volume I

- Shehryar, O., & Hunt, D. M. (2005). Buyer behavior and procedural fairness in pricing: Exploring the moderating role of product familiarity. *Journal of Product and Brand Management*, 14(4), 271–276. <https://doi.org/10.1108/10610420510609294>
- Xia, L., Kukar-Kinney, M., & Monroe, K. B. (2010). Effects of Consumers' Efforts on Price and Promotion Fairness Perceptions. *Journal of Retailing*, 86(1), 1–10. <https://doi.org/10.1016/j.jretai.2009.10.003>
- Yoon Kin Tong, D., Piew Lai, K., & fa Tong, X. (2012). Ladies' purchase intention during retail shoes sales promotions. *International Journal of Retail & Distribution Management*, 40(2), 90–108. <https://doi.org/10.1108/09590551211201856>

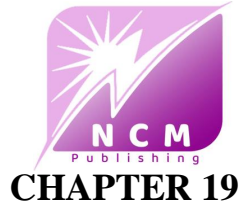

Employees' Performance Enhancement Based on Collaborative E-Learning and Mediated by Training in Bank Syariah Indonesia: A Human and Organization Development Perspective

Dewi Puspitaningtyas Faeni

Universitas Bhayangkara Jakarta Raya
dewi.puspaningtyas@dsn.ubharajaya.ac.id
Orcid: 0000-0002-1911-4425

Sri Wulandari, S.T

Universitas Bhayangkara Jakarta Raya
sri.wulandari@mhs.ubharajaya.ac.id
Orcid: 0009-0004-3195-9879

Rachmat Pramukty, M.Si

Universitas Bhayangkara Jakarta Raya
Rachmat.pramukty@dsn.ubharajaya.ac.id
Orcid: 0000-0002-8418-6396

ABSTRACT

This study aims to determine the effect of e-learning, industrial revolution 4.0, and collaborative learning on employee performance at Bank Syariah mediated by training. Data were collected by distributing questionnaires to 133 respondents, of which 100 were returned and analyzed using SmartPLS software. The results showed that Collaborative Learning has a positive (4.8%) and insignificant effect (76.0%) on Training Mediation. Training Mediation has a positive (73.3%) and significant effect (0.00%) on Employee Performance, while the e-Learning variable has a positive (11.8%) and significant effect (39.1%) on training mediation. Furthermore, the industrial revolution era 4.0 has a positive (58.9%) and significant effect (0.00%) on Training Mediation.

Keywords: E-Learning, Industrial Revolution Era 4.0, Collaborative Learning, Training Mediation, Employee Performance Syariah Banking

INTRODUCTION

PT Bank BRI Syariah Tbk (BRIS) officially changed its name to PT Bank Syariah Indonesia (BSI) after the merger with two state-owned Islamic banks, namely PT Bank Syariah Mandiri and PT Bank BNI Syariah, with the approval of the Financial Services Authority (OJK). OJK Logistics under the permit numbered SR-3/PB.1/2021. "The name change permit using the business license of PT Bank BRI Syariah Tbk, becomes a business license on behalf of PT Bank Syariah Indonesia Tbk as the bank resulting from the merger," quoted from *cnnindonesia.com*, Friday (29/1/2021). The name and logo, later BSI will use the BRI Syariah business license for business purposes. Then, BSI will manage changes to the articles of association at the Ministry of Law and Human Rights, changes or listing shares on the Indonesia Stock Exchange (IDX). Previously, Deputy Minister of SOEs targeted the merger process for state-owned Islamic banks to be completed in February 2021. Third the bank has also signed the deed of merger which signifies the start of the merger process. "We are grateful that the three banks that will be merged have signed the merger agreement, which is the first step for a legal merger which was originally scheduled to take place in February 2021," said Kartika. The initial capital of 214,6 trillion, with a core capital of more than Rp20.4 trillion. In addition, the merged bank will target MSME financing to large-scale infrastructure projects. Meanwhile, the majority of shares in the new entity will be held by PT Bank Mandiri (Persero) Tbk with 51.2 percent. Then, PT Bank Negara Indonesia (Persero) Tbk as much as 25 percent, PT Bank Rakyat Indonesia (Persero) Tbk 17.4 percent, DPLK BRI-Shaham Syariah 2 percent, and the public 4.4 percent (Wirjoatmodjo, 2022).

The rapid competitive pace and rise in employee performance among banks in the financial sector due to changes in the environment, technology, and science are becoming increasingly intense. This competitive pace led to the consolidation of Bank Mandiri Syariah and Bank BNI Syariah merged to form Bank Syariah Indonesia,. Therefore, organizations need to improve their employees' skills through training to maintain the development sustainably. Commercial banks, such as Bank Syariah, must increase their competitiveness by having qualified Human Resources (HR) with the ability to organize and plan properly to achieve the specified objectives. When the HR management carries out its function adequately, the work outcomes obtained exceeds the performance standards. Therefore, it is imperative to measure and assess the performance of each employee in the Bank Syariah Indonesia. Human resources are the driving force of creativity and innovation within a company, increasing its reputation and profit in the long run. Edi (2016) stated that when organizations can meet the psychological, social, physical, and financial factors, employees feel comfortable in their work environment. Work standards must be measured and understood to support employee performance assessment and promote its objectives (Faeni, 2017).

Human resource management is the science and art of regulating the relationship and role of the workforce to be effective and efficient in supporting the realization of the company's goals, employees, and society (Hasibuan, 2017). Presently, there is a significant rise in the development of human resources, and in accordance with this rise, companies must not only recruit employees based on their talents and abilities but also on their ability to carry out the task efficiently and effectively.



Irrespective of the numerous benefits and conveniences of using e-learning facilities, it creates a sense of laziness among employees. Therefore, companies must provide incentives to make the employees enthusiastic about learning in a more relaxed and flexible model. Strategies are needed to grow and survive in the business world to produce high-quality goods and services. This led to the transition from traditional training to e-learning for employees to work optimally, effectively, and efficiently. Therefore, the main purpose of a knowledge management system through digital banking is to improve employee competence in human resource management which has created a new culture for people globally.

The world is now shifting to the Industrial Revolution Era 4.0, where information technology has become the basis of human

life. Everything has become borderless with unlimited computing capability and data due to the evolution of the internet and massive digital technology as the core of the movement and connection of humans and machines. With the fast development of more sophisticated technology, every individual needs to discover all the human resources they possess to support their performance and daily tasks. Even the company's facility and infrastructure system are likely to expand and be enhanced, allowing it to grow in line with its current human resources. Many experts argue that the competency of each present employee determines the success or failure of a company. However, this takes a lengthy process and continuous efforts because this era tends to disrupt various human operations, with human resources being one of the most crucial parts of the company. The integration of information technology into the business world has strongly affected the effective, efficient, and sustainable use of sophisticated systems, such as e-learning. Many parties from academics, professionals, companies and industries are currently interested in e-learning.

1. DISCUSSION

Data on the theories justifying the role of e-learning, the Industrial Revolution 4.0, and Collaborative Learning on Employee Performance Mediated Training for Employees of BSI were collected from scientific books, preliminary studies, regulations, and electronic media. Wibawa and Cholifah (2016) stated that learning media is one of the methods used to support learning objectives. E-learning is based on the principle of learning to utilize electronic services as a tool not restricted by space or time. It is the unavoidable consequence of the advancement of information and communication technologies (Faeni, 2016).

1.1 E-learning

The implementation of e-learning varies greatly, but all are founded on the premise or notion that this process is intended to disseminate learning materials via electronic media or the internet. There are three crucial aspects of e-learning learning. First, it is related to electronic networks that allow information and instructions to be delivered. Second, e-learning is delivered to students using computers with an internet connection. Third, e-learning is the solution that goes beyond conventional training, including delivering information and tools to improve performance.

Rapid technological advancements have encouraged banks to expand their services with the establishment of digital banking. This platform aims to optimize banking performance in its customer services and increase operational quality while supporting employee training through technology. A digital banking system is also designed to allow customers to carry out activities, such as creating accounts, obtaining information, transactions, closing accounts, and other customer demands on their own. Banking industry actors need to be able to evaluate public needs in order to provide fast service. Additionally, the availability of sophisticated communication tools is increasingly driving the evolution of these services for people to access banking services anywhere and anytime easily.

1.2 Industrial Revolution

The industrial revolution is a fundamental change in humans' way of life and work processes, where advances in information technology can integrate the digital world of life and impact all disciplines. The rapid development of information technology has led to breakthroughs in artificial intelligence by creating automated applications. The development of digital technology in the industrial revolution 4.0 influences human life globally. This era is associated with an automation system and a fundamental basis for online trade and transportation. The advancement in technology also led to the evolution of several online transportation services, such as Go-Jek, Uber, and Grab, which demonstrate the integration of human activity, thereby increasing economic growth. These transportation companies did not only apply their strategies to business but also in employee training, including banking.

Industrial revolution 4.0 makes it faster for products to be developed, creates diverse consumers, and results in cheap prices. Changes in this era are not just shifting strategies or tactics in the marketing process due to the increase in several business model revolutions. First, businesses provide solutions to problems faced by the community. Second, companies are never satisfied with their results; therefore, they strive to innovate continuously. Third, there is a new monopolistic capitalism model in which corporations' business models comply with the sharing economy, thereby it is regarded as a solution to economic inequality. Fourth, the 3.0 marketing model rises with Era 1.0, 2.0, and 3.0 focused on products, marketing product users as consumers from the multidimensionality of humans to satisfy their desire for participation, creativity, community, and idealism.

The use of technology, such as digital banking in service innovation as a training medium to shape and provide more knowledge to meet customer needs is best understood in relation to services. Workers in all fields in the Industrial Revolution Era 4.0 are required to have digital-related skills. Service is not limited to serving but understanding and experiencing customers. Heart and mind shares foster customer loyalty to a product and positively impact the company's image. Service in conventional companies is provided to business people in physical form using Servqual indicators of constraints, guarantees, tangibles, responsiveness, and empathy. In the digital era, a new model capable of meeting customer needs in getting direct services is courtesy, friendliness, and personal care. A new measure of service quality that moderates customer satisfaction in digital banking has emerged, which has the potential and opportunity to increase the

interest of prospective customers and provide services to those still loyal to the bank. Since this study employs several service quality measures, such as experience, satisfaction, and loyalty, a significant relationship between digital banking and performance is possible. The technologies used include 3D Printing, Location Detection Technology, Advanced Human-Machine interfaces, and authentication and fraud detection.

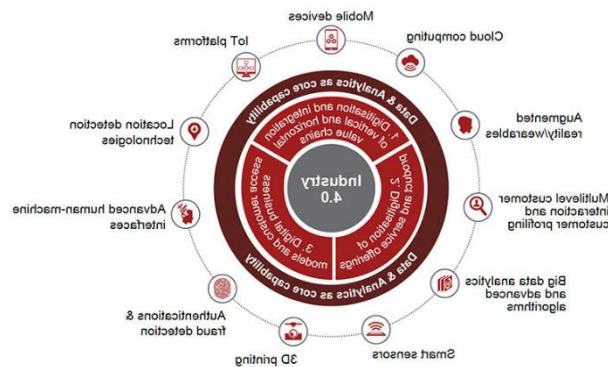

Figure 21
IR 4.0 Framework

1.3 Collaborative Learning

Industry players are increasingly convinced that artificial intelligence will play a bigger role in various sectors and be increasingly capable of being involved in numerous operational and strategic decisions in the Post-2017 Era. Therefore, they have adopted the use of collaborative learning, which is a technique used by two or more people to learn something together using each other's resources and skills by asking questions, assessing and monitoring ideas. More specifically, collaborative learning is based on a model in which knowledge is generated in a population whose members actively interact by sharing experiences and playing different roles. In other words, it refers to the environment and methods of student activities used to complete shared tasks in which each individual is dependent on and responsible to one another. This includes face-to-face and online discussions, such as forums, chat rooms, etc. The methods used to examine the collaborative learning process include conversational and statistical discourse analysis.

1.4 Trainings

Dessler (2016) stated that training teaches new employees the skills required to do their jobs. It is also defined as a program established and offered by the company to its employees to train and develop knowledge and skills that may be utilized later in careers or promotions. Training is also a planned effort by the company and employees to facilitate learning of job-related knowledge, skills, and behavior. The benefits of training can be seen from three perspectives: for employees, organizations, and human resource interactions within and

outside groups (Rivai and Sagala, 2016). According to Mangkunegara (2017), training consists of dimensions and indicators, such as the instructor, participants, materials, and objectives.

Performance is the implementation of the prepared plans comprising human resources with the necessary ability, competence, motivation, and interests needed for proper implementation. The attitude and behavior of employees will be affected by how the organization appreciates and treats its human resources.

The success rate of performance includes both quantitative and qualitative aspects, which is dependent on how employees carry out tasks assigned to them (Faeni, 2019).

The level of performance expected in an organization is a benchmark, goal, or target that depends on the approach taken. Therefore, good work standards must be realistic, measurable, and easy to understand to obtain the right strategies beneficial to the organization and employees (Abdullah, 2014). The expected level of a certain task to be conducted functions as a comparison for the goals or targets achieved, while an employee obtains work results according to job criteria or performance standards.

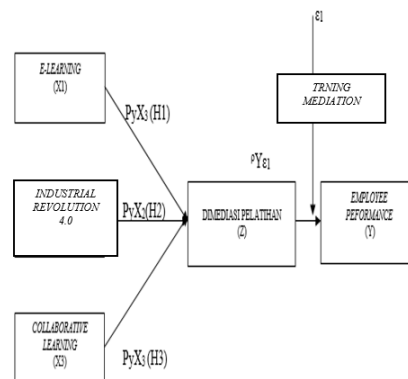

Figure 2.2

Research Framework

Based on the theoretical relationships described above, several hypotheses were formulated as follows:

H₁: There is a positive and significant effect of Collaborative Learning on Training Mediation

H₂: There is a positive and significant effect of Training Mediation on Employee Performance

H₃: There is a positive and significant effect of E-Learning on Training Mediation

H₄: There is a positive and significant influence of Industrial Revolution 4.0 on Training Mediation

2. RESEARCH METHODS

The object of this research is the employees of PT. Bank Mandiri, (Persero) Tbk. Bank Mandiri was formed by consolidating four Indonesian banks, namely Bank Bumi Daya, Bank Dagang Negara, Bank Pembangunan Indonesia, and Bank Export-Import. The descriptive and verification methods were used to carry out this research. According to Sugiyono (2013),

descriptive statistics are used to analyze data by describing it without drawing conclusions or making a generalization.

research was carried out using the simple random sampling process, which is very simple with a single unit of analysis (Slovin, 1994).

The iteration technique with the following formula was used to determine the minimum sample size in this study:

$$\begin{aligned} &\text{First iteration} \\ n &= N / (1 + N(e)^2) \\ n &= 133 / (1 + [(133(0,05))^2]) \\ n &= 133 / (1 + 133(0,0025)) \\ n &= 133 / (1 + 0,33) \\ n &= 133 / 1,33 \\ n &= 100 \end{aligned}$$

In the iteration above, the value of n is rounded down from 133 to 100 respondents.

Primary data were obtained from respondents' answers provided in the form of research questionnaires and were substantially decided by the valid and reliable criteria. The research instruments were tested for validity and reliability before data processing. Verification analysis was performed to determine the relationship between variables using SmartPLS 3.0, Partial Least Squares software.

PLS is also used to determine the reflective, flexibility and size of an algorithm that needs to be analyzed along with its numerous indicators (Ghozali, 2008).

3. RESULTS

The random sampling technique was used to collect data from 100 employees at PT. Bank Mandiri Tbk. using a questionnaire. The data collected were verified using the SmartPLS 3.0 software to determine the relationship between variables through hypothesis testing. This analysis consists of the following stages:

a. Measurement Model Evaluation (Outer Model)

Measurement model evaluation is the relationship between variables and their indicators used to test the validity and reliability of the equation obtained by running the PLS Algorithm on SmartPLS 3.0 Software. Figure 4.1 shows the output of the PLS Algorithm process:

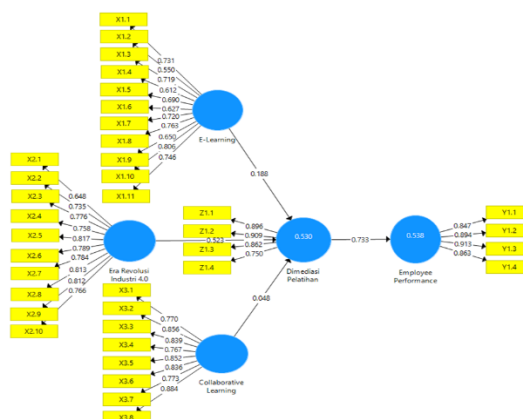

• **Validity Test**

The validity test in SmartPLS 3.0 can be evaluated in two ways, namely convergent and discriminant. Convergent validity is determined by the loading factor value, whereas discriminant is evaluated by the Average Variance Extracted (AVE) value, square root of AVE, and cross-loadings.

The loading factor describes how much the indicators are related to each variable. According to the Rule of Thumb Evaluation of the Measurement Model, the loading factor value is considered valid above 0.5 (>0.5). Each indicator's loading factor analysis is as follows:

Table 4.1
Cronbach's Alpha of the Variables

	<i>Cronbach's Alpha</i>
<i>Collaborative Learning</i>	0.932
<i>Training Mediation</i>	0.878
<i>E-Learning</i>	0.868
<i>Employee Performance</i>	0.902
<i>Industrial Revolution 4.0</i>	0.923

Source: Data Processed 2020

Table 4.11 shows that the Cronbach's alpha value of each variable has a value of more than 0.7

Table 4.2
Results of Composite Reliability Test

	<i>Composite Reliability</i>
<i>Collaborative Learning</i>	0.944
<i>Training Mediation</i>	0.916
<i>E-Learning</i>	0.901
<i>Employee Performance</i>	0.932
<i>Industrial Revolution 4.0</i>	0.936

Table 4.2 shows that the composite reliability value of each variable is greater than 0.5 or (>5%)
(%)

Table 4.3
Reliability Test

Variable/Construct	Test Results		Reliability
	<i>Cronbachs Alpha()</i>	<i>Composite Reliability()</i>	
<i>Collaborative Learning</i>	0.932	0.944	Reliable
<i>Training Mediation</i>	0.878	0.916	Reliable
<i>E-Learning</i>	0.868	0.901	Reliable
<i>Employee Performance</i>	0.902	0.932	Reliable
<i>Industrial Revolution 4.0</i>	0.923	0.936	Reliable

Source: Data Processed 2020



Based on Table 4.13, it can be seen that the Cronbach's alpha and composite reliability values of each variable are greater than 0.7 and 0.5 or ($> 5\%$). Therefore, it can be concluded that all constructs are reliable.

1) Convergent Validity.

The convergent validity value is the latent variable's loading factor with its indicators above 0.7 (>0.7).

Table 4.4
Validity Test

Statement Number	Test Results	Validity
<i>E-learning (X1)</i>		
X1.1 (Statement 1)	0.731	VALID
X1.10 (Statement 2)	0.806	VALID
X1.11 (Statement 3)	0.746	VALID
X1.3 (Statement 4)	0.719	VALID
X1.5 (Statement 5)	0.690	VALID
X1.7 (Statement 6)	0.720	VALID
X1.8 (Statement 6)	0.763	VALID
X1.9 (Statement 6)	0.650	VALID
<i>Industrial Revolution 4.0 (X2)</i>		
X2.10 (Statement 7)	0.766	VALID
X2.2 (Statement 8)	0.735	VALID
X2.3 (Statement 9)	0.776	VALID
X2.4 (Statement 10)	0.758	VALID
X2.5 (Statement 11)	0.817	VALID
X2.6 (Statement 12)	0.789	VALID
X2.7 (Statement 13)	0.784	VALID
X2.8 (Statement 14)	0.813	VALID
X2.9 (Statement 15)	0.812	VALID
<i>Collaborative Learning (X3)</i>		
X3.1 (Statement 16)	0.770	VALID
X3.2 (Statement 17)	0.856	VALID
X3.3 (Statement 18)	0.839	VALID

**Accounting Inquiries with New Approaches in the Post-Pandemic Era
Volume I**

Statement Number	Test Results	Validity
X3.4 (Statement 19)	0.767	VALID
X3.5 (Statement 20)	0.852	VALID
X3.6 (Statement 21)	0.836	VALID
X3.7 (Statement 22)	0.773	VALID
X3.8 (Statement 23)	0.884	VALID
<i>Training Mediation (Z)</i>		
Y1.1 (Statement 24)	0.896	VALID
Y1.2 (Statement 25)	0.909	VALID
Y1.3 (Statement 26)	0.862	VALID
Y1.4 (Statement 27)	0.750	VALID
<i>Employee Performance (Y)</i>		
Y1.1 (Statement 28)	0.847	VALID
Y1.2 (Statement 29)	0.894	VALID
Y1.3 (Statement 30)	0.913	VALID
Y1.4 (Statement 31)	0.863	VALID

Source: Output of SmartPLS 3.0

The convergent validity test result in Table 4.14 showed that all statement indicators from the Social media variable are valid because the value is > 0.7 , which means that all statements can be processed. Similarly, the internet, communication, and academic achievement are valid; hence, they can all be used for data processing.

2) Discriminant Validity.

The discriminant validity is the value of the cross-loading factor used to determine whether the construct has an adequate discriminant by comparing the loading value on the intended construct, which needs to be greater than the loading value with other constructs.

**Table 4.5
Discriminant Validity**

	<i>Collaborative Learning</i>	<i>Training Mediation</i>	<i>E-Learning</i>	<i>Employee Performance</i>	<i>Industrial Revolution 4.0</i>
<i>Collaborative Learning</i>	0.8				
<i>Training Mediation</i>	0.6	0			
<i>E-Learning</i>	0.7	0.6	0.6		
<i>Employee Performance</i>	0	0.7	0.6	0.8	
<i>Era Revolusi 4.0</i>	0	0	0.8	0.7	0.7

Source: Data Processed 2020

3) Composite Reliability

A construct is reliable assuming it fits the value criteria outlined in Table 3.3 for the Rule of Thumb Evaluation of the Measurement Model (Outer Model), namely Cronbach's alpha, composite reliability, and AVE value of > 0.7 , > 0.5 , and > 0.5 , as shown in Table 4.16:

Table 4.6
Construct Reliability and Validity

Matrix	Cronbach's Alpha ()	rho_A	Composite Reliability	Average Variance Extracted (AVE)
<i>Collaborative Learning</i>	0.932	0.937	0.944	0.678
<i>Training Mediation</i>	0.878	0.897	0.916	0.733
<i>E-Learning</i>	0.868	0.892	0.901	0.604
<i>Employee Performance</i>	0.902	0.902	0.932	0.774
<i>Era Revolusi 4.0</i>	0.923	0.929	0.936	0.618

Source: Data Processed 2020

Table 4.6 shows that the reliability tests, including Cronbach's alpha, rho_A, and Composite Reliability for E-Learning (X1), Industrial Revolution 4.0 (X2), Collaborative Learning (X3) and Employee Performance (Y) and Training Mediation (Z) are all reliable with a value > 7 .

4) Average Variance Extracted (AVE)

The AVE value measures the number of variances that the construct can capture compared to the variances due to errors. The AVE value must be greater than 0.5 (> 0.5).

Table 4.3 shows that all variables have an AVE value greater than 0.5, meaning that the construct can accept more than 50% of the indicators.

Table 4.7
Average Variance Extracted (AVE) Value

Matrix	AVE
<i>Collaborative Learning</i>	0.67
<i>Training Mediation</i>	0.73
<i>E-Learning</i>	0.60
<i>Employee Performance</i>	0.77
<i>Era Revolusi 4.0</i>	0.61

Sumber: Output SmartPLS 3.0-2020

Table 4.7 shows that the AVE value of each variable is greater than 0.5, indicating that it is discriminately valid.

a. Inner-Model

Inner model can be conducted in three methods by analyzing the R Square (R²), Predictive Relevance (Q²), and Goodness of Fit (GoF). The Q² formula is $Q^2 = 1 - (1 - R^2)(1 - R^2)^2 \dots (1 - R^2)^p$, while the GoF value must be calculated manually by PLS-SEM. The results of the Inner Model Analysis are as follows:

Table 4.8
Inner Model Analysis

Accounting Inquiries with New Approaches in the Post-Pandemic Era
Volume I

Variable	Average Variance Extracted (AVE)>0.5%	R Square	Q ²	GoF
Collaborative Learning	0.6			
Training Mediation	0.7			
E-Learning	0.6			
Employee Performance	0.7	0.5	0.473	0.618
Industrial Revolution 4.0	0.6	0.5		0.573

An inner or structural model analysis is used to determine the relationship between constructs and the significance value of the research model, evaluated using the t-statistic value. The bootstrapping method is also used to find the results of the Inner model evaluation on the SmartPLS 3.2 software. Figure 4.3 shows the result of the structural model after the bootstrapping process:

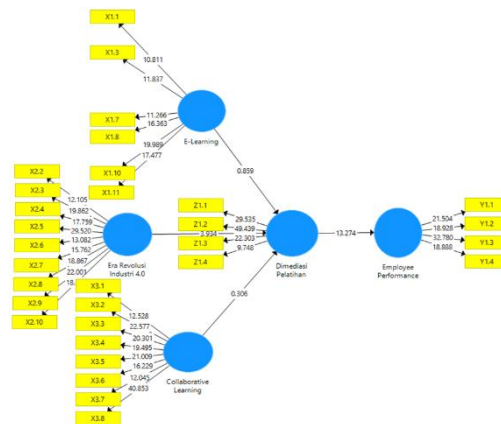

Figure 4.3: Inner Model (Path Bootstrapping)

Source: Data Processed 2020

Table 4.9 shows an insignificant direct effect of Collaborative Learning on training mediation with a P-value of 0.760, which is above 5% significance. Besides, there is a significant direct positive effect of Training Mediation on Employee Performance because the P-value is less than 0.5 (<5%). E-Learning has a significant direct effect on training mediation with a P value of less than 0.5 (<5%). Subsequently, there is a significant direct positive effect of Industrial Revolution Era 4.0 on training mediation with a P value of less than 0.5 (<5%).

The hypothesis test was then used to decide based on the original sample estimate and t-statistics. The hypotheses were tested as follows:

H₁: There is a positive and significant effect of Collaborative Learning on Training Mediation

Path Coefficients

	T Statistics (O/STERR)	P Values	Significance
Collaborative Learning -> Training Mediation	0.306	0.760	Not significant
Training Mediation -> Employee Performance	13.274	0.000	Significant
E-Learning -> Training Mediation	0.859	0.391	Non-significant
Industrial Revolution 4.0 -> Training Mediation	3.934	0.000	Significant

Source: Data Processed 2020



The original sample has a positive t-statistic and p values of 0.048, 0.306 or 30.6% which is above > 1.96 significance, and 0.760 or 76.0%, which means it is insignificant. The test results show that Collaborative Learning has a negative and insignificant effect of 4.8% and 76.0%, respectively on training mediation; therefore, H_1 is rejected.

H_2 : There is a positive and significant effect of Training Mediation on Employee Performance

Based on the test results, it shows that the original sample has a positive t-statistic and p values of 0.733, 13.274 or 13.274%, and 0.000 or 0.00% with a significance criteria above 5%, which means that it is significant. The test results show that Collaborative Learning has a positive (73.3%) and significant effect (0.00%) on training mediation; hence, H_2 is accepted.

H_3 : E-Learning has a positive and significant effect on Training Mediation.

The test results show that the original sample has a positive t-statistic and p-values of 11.8, 0.859 or 85.9%, which is above 1.96%, and 0.391 or 39.1%, which means it is insignificant. The test results show that E-Learning has a negative (11.8%) and insignificant (39.1%) effect on training mediation; consequently, H_3 is rejected.

H_4 : There is a positive and significant influence from the Industrial Revolution Era 4.0 on Training Mediation

The result shows that the original sample has a positive, t-statistic and p-values of 0.589, 3.934 or 3.934%, and 0.000 or 0.00%, which implies that it is significant at a rate above 1.96%. The test results show that the Industrial Revolution Era 4.0 has a positive (58.9%) and significant (0.00%) effect on training mediation; thereby, H_4 is accepted.

Discussion

a. There is no significant effect of Collaborative Learning on Training Mediation.

The partial test shows negative effect of Collaborative Learning on training mediation. This implies that the management of employees at PT. Bank Mandiri Tbk has not been able to give a significant effect directly on the training mediation for the employees with work achievement and an insignificant direct.

b. The Effect of Training Mediation on Employee Performance

The results indicate that training and development are two indicators needed to support career and work needs. Training and development materials can be applied to work because they increase knowledge and skill significantly affect employee performance based on the targets set by the company on time, re-scheduling, and inability to procrastinate. Training mediation is aimed at the career development process and e-learning and supports the availability of a new system for employees to obtain high performance.

c. There is no effect of E-Learning on Training Mediation

The partial test shows a negative and significant effect of e-learning on training mediation, which denotes it cannot provide quick results with difficulty in using up-to-date materials. Examination methods such as tasks via an e-learning system are fair to the employees, therefore, it needs to be applied more consistently. In other words, the better the knowledge management, the higher the employee satisfaction and engagement at work.

d. The Effect of the Industrial Revolution 4.0 on Mediated Training

The partial test shows a positive and significant effect of the Industrial Revolution Era 4.0 on training mediation. The availability of sophisticated E-Learning Technology improves Employee Knowledge, work pace, eases tasks, and becomes a source of appropriate learning. E-Learning improves Employee Performance and training mediation; therefore, it supports career and job needs, using training materials, which increases workers' knowledge and skills.

CONCLUSION

Based on the discussion in the previous chapters, the results of data analysis, as well as partial and simultaneous hypothesis testing, can be concluded as follows:

1. Collaborative learning has a negative and significant effect on the training mediation for BSI employees.
2. Mediated training has a positive and significant impact on Employee Performance.
3. E-Learning has a negative and significant effect on the training mediation for employees.
4. The Industrial Revolution Era 4.0 has a positive and significant effect on the training mediation for employees.

Managerial Implications

1. This research provides several important implications, especially for BSI to improve employee performance.
2. The result shows that this bank still needs to strengthen employee interaction to improve its performance.
3. Based on E-Learning in the Industrial Revolution 4.0 Era, employees in all fields are required to have digital capabilities and enhanced knowledge through the availability of E-Learning Technology.

Collaborative learning mediated by Training on Employee Performance needs to ensure employees stop procrastinating any work assigned by the leader and possess a broad range of knowledge and abilities.

REFERENCES

- Amelia, D., L Syukmayettil, Zuripal. (2021). The Effect of Business Knowledge, Business Skill, Self Confidence and Innovation on Business Performance of Small and Medium Industry in The City of Bukittinggi. IOP Conference Series: Earth and Environmental Science, 2021.
- Arikunto, S., (2002). *Prosedur Penelitian, Suatu Pendekatan Praktek.*, Jakarta: Rineka Cipta
- Bernadin, H.J., & Russel, Joyce. A. (1992). *Human Resource Management (An Experimental Edition)*. Singapore: Mc Graw Hill Inc.
- Buckingham, M., & Vosburgh, R.M. (2001). *The 21st Century Human Resources Function: It's The Talent, Stupid! Human Resource Planning*, Vol.24..No.4.
- Coleman, A. (2006). *Collaborative Leadership in Extended Schools*. National College for School Leadership. *Human Resource Management Review*, Vol. 19: 304-313.
- Dessler, G. (2006). *Manajemen Sumber Daya Manusia Edisi Kesepuluh Jilid 1 (terj.)*. Jakarta: Indeks Manajemen.
- Inah, Nur Inah Ety dan Utami Anggun Pertiwi. (2017). Penerapan Collaborative Learning melalui Permainan Mencari Figure untuk meningkatkan hasil belajar IPA kelas V di SDN Tanggele, Kecamatan Anggalmoare Kabupaten Konawe *Jurnal Al-Ta'dib* Vol. 10 No. 1, Januari-Juni 2017.
- Faeni, Dewi P., Ratih Puspitaningtyas Faeni, Dewi Puspaningtyas Faeni, Hakam Ali Niazi Ravindra Safitra Hidayat, Retno Fuji Oktaviani (2017). Influence of Leadership, Organizational Culture and Commitment to the Effectiveness of Independent Bank Employee Performance. *Journal of Law and Society Management* 6 (1) © Nabu Research Academy, Paages 163-168. 2019



- Faeni, Dewi P., Ratih Puspitaningtyas Faeni. (2019) Determinants That Affecting Accounting Information System Success and Its Implication on Accounting Information Quality in ERP Environment: Empirical Study on the Indonesian Plantation Company Anita Wahyu Indrasti, Dewi Puspitaningtyas Faeni, Indah Rahayu Lestari, Berlian Karlina, ICT4BL 2019 - International Conference on IT, Communication and Technology for Better Life. Pp: 108-113. 2019.
- Faeni, Dewi P., Ratih Puspitaningtyas Faeni, Hakam Ali Niazi Ravindra Safitra Hidayat, Retno Fuji Oktaviani (2017). Influence of Leadership, Organizational Culture and Commitment to the Effectiveness of Independent Bank Employee Performance. *Journal of Law and Society Management* 6 (1) © Nabu Research Academy, Paages 163-168. 2019
- Faeni, Dewi P., Ratih Puspitaningtyas Faeni, (2017) Absorptive Capacity, Creativity Development and Participation Intention Toward SMES Knowledge Alliances in E-Technology. *Journal of Biomedic and Comset IJCTA*. Volume 5 No.3. 2017.
- Faeni, Dewi P., Ratih Puspitaningtyas Faeni, (2016). Cognitive Style and Composition of Employees in Shaping Intellectual Sales Team. *Business Economig Social Science Humanities Conference (BESSH)*. Volume 11. Pages: 56-62. Willey Publisher. 2016/9.
- Gadis Ayu Putri Gayatri, Amir Imbaruddin, Muttaqin, (2018). Analysis of Employee Performance In Pt. Bank Mandiri (Persero), Tbk. Cendrawasih Makassar Branch. *Jurnal Administrasi Negara*, Volume 24 Nomor 3, Desember (2018)
- Hakim Arif Rahman. (2018). Pengembangan E-Learning Berbasis Moodle Sebagai Media Pengelolaan Pembelajaran. *Jurnal Kodifikasi*, Volume 12. No. 2, tahun 2018
- Hamdan, (2018). Industri 4.0: Pengaruh Revolusi Industri Pada Kewirausahaan Demi Kemandirian Ekonomi. *Industri 4.0 Jurnal Nusamba* Vol. 3 No.2 Oktober 2018.
- Hardidanto, Dimas Satrio, Permata Wulandari. (2016). Islamic Bank Vs. Conventional Bank: Intermediation Fee Based Service Activity and Efficiency. *International Journal of Islamic and Middle Eastern Financeal and Management*. Volume 5. No.4. 2016.
- Hanny Hafiar, Lilis Puspitasari. (2014). E-Learning: Media Substitusi Pembelajaran Dalam Upaya Peningkatan Kualitas SDM Melalui Kegiatan Humas Internal. *Jurnal Ilmiah Komunikasi / Volume 3 / Nomor 2* Desember 2014.
- Hoedi Prasetyo, Wahyudi Sutopo, (2018). Industri 4.0: Telaah Klasifikasi Aspek dan Arah Perkembangan Riset. *J@ti Undip: Jurnal Teknik Industri*, Vol. 13, No. 1, Januari 2018.
- I Gede Agus Krisna Warmayana, (2018). Pemanfaatan Digital Marketing Dalam Promosi Pariwisata Pada Era Industri 4.0 *Jurnal Pariwisata Budaya*, Volume 3, Nomer 2, Tahun 2018 Halaman 81-92
- Ike Yustanti, Dan Dian Novita. (2019). Pemanfaatan E-Learning Bagi Para Pendidik Di Era Digital 4.0 Utilization Of E-Learning For Educators In Digital Era 4.0. *Prosiding Seminar Nasional Pendidikan Program pasca sarjana Universitas PGRI. Palembang* 12 Januari 2019
- Indah Purnama Sari. (2017). Implementasi Pembelajaran Berbasis E-learning Menggunakan Claroline, Research and Development. *Journal of Education* Vol. 4 No. 1 Oktober 2017 ISSN 2406-9744
- Intan Mutia. (2013). Kajian Penerapan E-Learning Dalam Proses Pembelajaran Di Perguruan Tinggi. *Faktor Exacta* 6 (4): 278-289, 2013 Issn: 1979-276x
- Julianry Anriza, Rizal Syarif, dan M. Joko Affandi. (2019). Pengaruh Pelatihan Dan Motivasi Terhadap Kinerja Karyawan Serta Kinerja Organisasi Kementerian Komunikasi Dan Informatika. E-Issn: 2460-7819P-Issn: 2528-5149, Nomor Doi: 10.17358/Jabm.3.2.236. *Jurnal Aplikasi Bisnis Dan Manajemen*, Vol. 3 No. 2, Mei 2019.
- Jumawan, Martin Tanjung Mora. (2015). Pengaruh pelatihan dan pengembangan karier terhadap kinerja karyawan perusahaan korporasi, *jurnal riset manajemen dan bisnis (jrmb) fakultas ekonomi uniat* vol.3, no. 3 oktober 2018: 343 - 352 p-issn 2527-7502 e-issn 2581-2165, journal homepage: <http://jrmb.ejournal-feuniat.net/index.php/JRMB>
- La Hadisi dan Wa Muna. (2015) Pengelolaan Teknologi Informasi dalam Menciptakan Model Inovasi Pembelajaran (E-learning), *Jurnal Al-Ta'dib* Vol. 8 No. 1, Januari-Juni 2015
- Leni Rohida, (2018). Pengaruh Era Revolusi Industri 4.0 terhadap Kompetensi Sumber Daya Manusia. *Jurnal Manajemen Bisnis Indonesia* Vol. 6, Nomor 1 Oktober 2018
- Lewis, R.E., & Heckman, R.J. (2006). Talent Management: A Critical Review. *Human Resources Management Review*. Vol.16 (Hidayat, Penerjemah). Jakarta: Bhuana Ilmu Populer.
- Malkawi, Nazem, Mohammad, Haidar, S. Mohailan. (2022). E learning adoption during Covid-19 crisis and its effort on achievieng students' performance: evidence from Jordanian Universities. *Journal of Technology and Science Education*. Volume 4., Issue 2. 2022.

Accounting Inquiries with New Approaches in the Post-Pandemic Era
Volume I

- Mukhammad Hilmi Muzakki, Heru Susilo, Saiful Rahman Yuniarto (2016). Pengaruh Penggunaan Teknologi Informasi Terhadap Kinerja Karyawan (Studi Pada Karyawan PT. Telkom Pusat Divisi Regional V Surabaya) *Jurnal Administrasi Bisnis (Jab)* | Vol. 39 No.2 Oktober 2016|
- N. Lilis Suryani, (2020). Pengaruh Pengembangan Karir Dan Disiplin Terhadap Kepuasan Kerja Karyawan Pada PT. Qeon Interactive - Jakarta Pusat, *Jurnal Ilmiah, Manajemen Sumber Daya Manusia. JENIUS. Vol. 3, No. 2, Januari 2020*
- Novi Rukhviyanti. (2018). Pengaruh Penggunaan Teknologi Informasi Terhadap Kinerja Karyawan. *Jurnal Informasi Volume X No.2 / November / 2018*
- Numiek Sulisty Hanum (2013). Keefektifan E-Learning Sebagai Media Pembelajaran (Studi Evaluasi Model Pembelajaran E-Learning Smk Telkom Sandhy Putra Purwokerto). *Jurnal Pendidikan Vokasi, Vol 3, Nomor 1, Februari 2013.*
- Nur Kholis, (2018). Perbankan Dalam Era Baru Digital. *Economicus, Vol.9 No. 1 Juni 2018 E-Issn: 2615 – 8078*
- Rahman, A & Hasan, N. (2017). Modeling Effect of KM and HRM Processes to the Organizational Performance and Employee's Job Satisfaction. *International Journal of Business and Management Vol. 12, No. 7: 35-45.*
- Rima Handayani, Via Soliha. (2020). Pengaruh Disiplin Kerja Dan Suasana Kerja Terhadap Kinerja Karyawan Pada PT. Gunung Agung Tangerang Selatan. *Jurnal Ilmiah, Manajemen Sumber Daya Manusia. JENIUS. Vol. 3, No. 2, Januari 2020.*
- Saptono, Ari., Agus Wibowo, Bagus Shandy, Namaditya, Rr. Ponco Dewi Karyaningsih, Heri Yanto. (2020). Does Entrepreneurial education matter for Indonesian preparation: The mediating role of entrepreneurial mindset and knowledge, *Cognitive Education.*
- Simamora, H. (2004). *Manajemen Sumber Daya Manusia edisi Bahasa Indonesia.* Yogyakarta: STIE YKPN.
- Suharman, Hari Wisnu Murti (2019). Study On Industry 4.0 For The Application In Indonesia. *Jurnal Manajemen Industri Dan Logistik Vol. 03 No. 01 (01-13)*
- Timpe, A. Dale. (1996) *Seri Manajemen Sumber Daya Manusia: Kinerja* (Sofyan Cikmat, Penerjemah). Jakarta: PT Alex Media Komputindo.
- Wahyono, N.D., N Hasanah, S.B. Kusuma. (2021). Analysis up-stream agribusiness and counseling beef cattle development in Jember. *IOP Conference Services: Earth and Environmental Science, 2021.*
- Yosep Satrio Wicaksono. (2016). Pengaruh Pelatihan Dan Pengembangan Sumber Daya Manusia Dalam Rangka Meningkatkan Semangat Kerja Dan Kinerja Karyawan (Studi Di Skm Unit V Pt. Gudang Garam Tbk Kediri). *Jurnal Bisnis Dan Manajemen Vol. 3 No.1, Januari 2016*



CHAPTER 20

Design of Research Reporting and Data Collection Information System at Public University Using The Design Thinking Method

Ms. Kendry Ayu Laksana

Institute Teknologi Sepuluh November
kendryayulaksana@gmail.com

Ms. Ika Raharja Salim

Institute Teknologi Sepuluh November
Universitas Ciputra Surabaya
ika.salim@ciputra.ac.id
Orcid: 0000-0002-9851-3327

Wirawan E. D. Radianto

Universitas Ciputra Surabaya
wirawan@ciputra.ac.id
Orcid: 0000-0001-6569-7142

ABSTRACT

Current digital developments encourage the world of education to also participate in developing a digitalization environment, especially in higher education. Not only in terms of the learning process, but also in the managerial process, especially in the tridharma business process. This research aims to develop higher education information systems to be more efficient and effective, especially in research business process, namely the process of data reporting and data management. The method used in this research is design thinking, which consists of the empathize, define, ideate, prototype, and testing stages. At the empathize stage, data is collected in the form of strategic plan documents which are then mapped in the form of a business model canvas. Then a user interview is conducted which is then mapped into an empathy map. At the define stage, the results of the interview are detailed in the form of a user persona. From the results of document mapping and user interviews, we enter the ideate stage, namely making user flows and flowcharts. After validating user flow and flowcharts for the user, the prototype stage is carried out, where at this stage Balsamiq 3 tools are used to design the user interface. The results of this study indicate that the designed user interface and flow are in accordance with user needs.

Keywords: Information system; design thinking; public university; reporting; data

INTRODUCTION

The era of digitalization which is dynamic and continues to move forward, requires all industries to be able to adapt, especially education. Digitalization in education, especially at universities, was first introduced in the 1960s at Stanford University, namely the use of computers in the learning process (Keegan, 2020). In the 1970s lectures were held online, and in the 1990s the LMS or Learning Management System was introduced. However, with the emergence of the Covid-19 pandemic, the digitalization process in the education industry is increasingly required to cover all aspects of implementation, both learning and managerial (Marinoni, van't Land, & Jensen, 2020).

The application of digitalization in higher education is also considered a significant change, based on the results of a survey conducted by the University of Oldenburg in Germany, 74% of lecturers stated that the workload on online lectures was heavier, and 42% of lecturers preferred hybrid lectures rather than completely online. (Richter, 2020). Through the Covid-19 pandemic, educational institutions, especially higher education institutions, are working hard to create an information system that not only facilitates the learning process for the academic community, but also ensures that management processes can be carried out online (Richter, 2020). This online management process includes access to all data that can be accessed from anywhere, to support the WFH (Work From Home) process. In this research, researchers will design a new information system user interface.

Based on the analysis of the company's condition, the results of the mapping of the university's strategic plan documents resulted in the Business Model Canvas or BMC, which later identified that tridharma is the main key activity. Tridharma itself consists of teaching, research and community service. This research focuses on business process research, which is under the research and community development department or in Indonesia LPPM short for Lembaga Penelitian dan Pengabdian Masyarakat. From this business process, it is revealed in BMC research and community development, where the main points in the key activities of research and community development that are highlighted are verification services, documentation, research & community service data administration, as well as data presentation for stakeholders. Analysis of the company's condition also shows that there is an urgency for efficient reporting and data management. Where based on key performance indicators (KPI), information system needs and key research and community development activities account for 60% of the total KPI.

Analysis of the condition of the company is also then followed by an interview process with users, where user opinions play an important role in the user interface development process. In this study, the user persona was also explained based on the results of interviews conducted, the results showed that users have the same need for the presence of a system to assist in the process of managing research data. Based on the explanation of the problems originating from these users, supported by the demands for digitalization in the management process, the researchers tried to analyze and design information system solutions that can support the process of reporting and research data collection at Private University by applying the Design Thinking method.

1. Literature Review

1.1 Information System

Information systems have the benefit of being a place to store a number of data containing company information (Pauziah, 2022). The information system itself is defined as a system that helps manage information, such as storing, organizing, and retrieving information. According to Laudon, K. C., & Laudon, J. P. (2016) the benefits of information systems for organizations can include:

1. Improved Operational Efficiency
2. Better Decision Making
3. Improved Coordination and Collaboration
4. Improved Customer Service
5. Competitive Advantage

1.2 Business Model Canvas (BMC)

The Business Model Canva or BMC was first introduced by Alexander Osterwalder (2004). However, the development of BMC was then introduced in a simpler form called canvas and introduced by Osterwalder and Pigneur (2010), which introduced important indicators of BMC:

1. Customer Segments
2. Value Propositions
3. Channels
4. Customer Relations
5. Revenue Streams
6. Key Resources
7. Key Activities
8. Key Partners
9. Cost Structure

1.3 Design Thinking

Design Thinking is a method introduced by David Kelley and Tim Brown. This approach involves a series of stages that are carried out repeatedly, and do not always follow a linear or sequential order (Puspita, Niniek F., 2023) as shown in Figure 1.

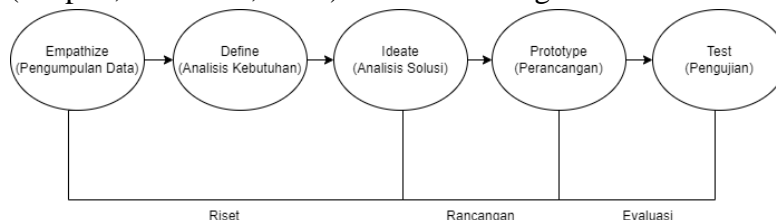

Figure 1. Design Thinking Method based on Dell'Era et al. (2020)

Design thinking consists of several stages including:

1. Empathize

According to Hasso Plattner (2010) this stage involves deeply understanding users, their goals, their needs, and the challenges they face. The results of observations on the empathy process are then analyzed to find/identify the focus of the problems faced by users (Sari et al., 2020). This empathy process must be interpreted as a number of things, namely observation where researchers must examine users and their behavior in the context of their lives, attachment, namely interacting or communicating with users on scheduled or incidental occasions and immersion, namely trying to experience what users also experience (T. Tatang, 2023) .

2. Define

After gaining insight from the Empathize stage, this stage involves formulating a specific problem and focus. At the end of this stage, the design team must have a clear definition of the problem to be solved (Plattner, 2010). The information that has been collected is also then analyzed and synthesized to determine the core problem. This definition is called a problem statement.

3. Ideate

The ideas obtained through the brainstorming process will generate ideas in the form of solutions to the problems faced by users (Wibowo & Setiaji, 2020). In describing this stage, you can generally use diagrams or tables that represent the results of the analysis. Several previous studies have used userflow, sitemap, and flowcharts. The function of userflow is to make it easier for designers to determine the flow before making a system design and avoid navigation that is too complicated to make it easier for users (user friendly) (Wulandari & Widianoro, 2017). In addition, there are also stages of making a wireframe to make it easier for designers to design the system interface. Meanwhile, a flowchart is a diagram of a system flow that will show logic.

4. *Prototype*

According to Hasso Plattner (2010) this stage involves creating a concrete prototype or visual representation of the proposed solution. This prototype can be a physical model, drawing, storyboard, or even a simple digital prototype.

The stages of the prototyping method according to Marthasari, Risqiwati, and Dewi (2017) are described as follows:

1. Analysis of system requirements
2. System design
3. Implementation of prototypes
4. Prototype testing
5. Test

The user performs final testing of the prototype, at this stage the user often uses the results of trials and prototype evaluations to redefine one or more further problems.

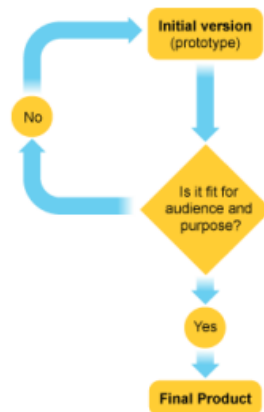

Figure 2. Testing Stage

Sumber: Bullock, 2015

https://dloft.stanford.edu/sites/default/.../college_access_design_challenge_slides.pptx

Testing on system design is carried out to improve problem solutions, get feedback from users, and study users more deeply in order to get better information system design results according to the wishes of users (Karnawan et al., 2020). There are many methods to get user feedback, one of which is the User Perception Survey. The User Perception Survey aims to understand the user's perception of the system display. This survey may contain questions about visual impression, ease of use, text readability, and the effectiveness of other display elements (Tullis, T. and Albert, B., 2023).

2. METHOD

In this study the method used is a descriptive qualitative research method. The stages of the research carried out will adopt the process of the design thinking method where this design thinking has 5 stages including Empathize, Define, Ideate, Prototype and Testing. The implementation of each process in design thinking provides ideas for finding and solving problems in this information system design development project. A consumer-centered Design Thinking approach to produce system designs that are able to solve problems faced by users. It can be seen in Figure 9 that there is a systematic relationship between one process and another.

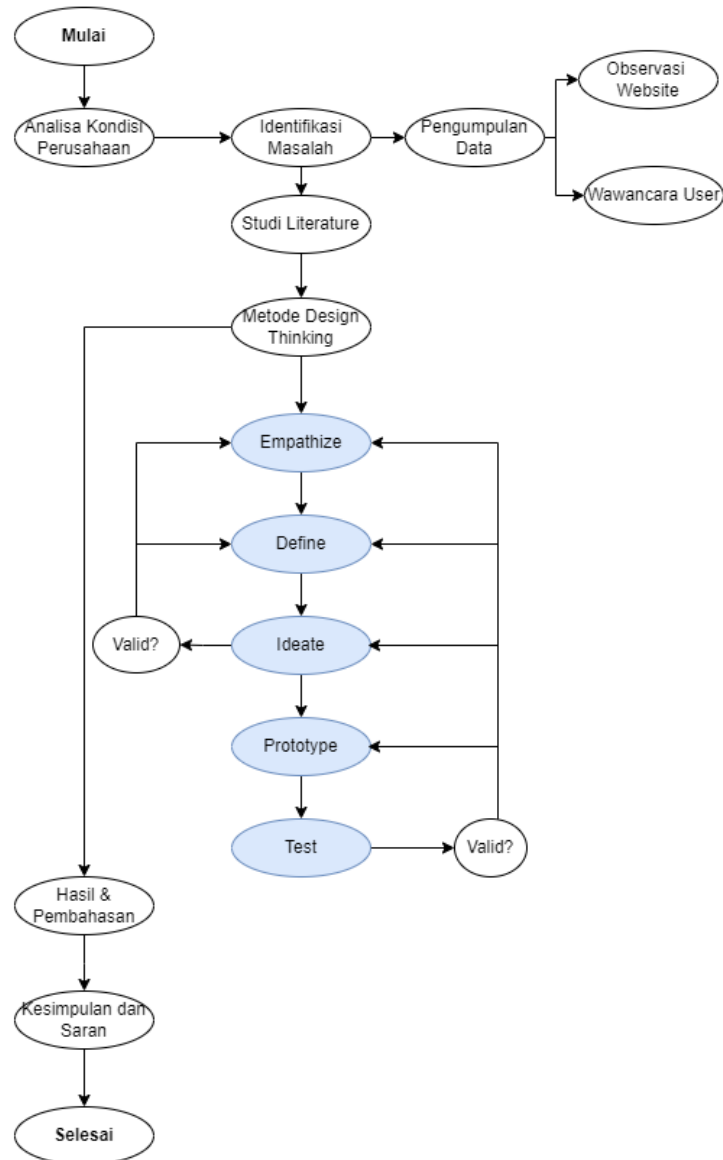

Figure 3. Design Thinking Method

In the design thinking framework, all stages have the same important goal, but in this research the prototyping stage is the main stage where in this stage the process of making a working model of the proposed system is carried out using the database desired by the user and then it will be evaluated in terms of appearance. and functions before being realized (Dalis, 2017).

3. RESULT AND DISCUSSION

3.1 Emphathize

Empathy Map is a process of gathering information for design needs with a user-centered approach that focuses on understanding other individuals by seeing the world through users.



Figure 4. Empathy map Dr. Budi Darmo, S.E., M.M

The results of Budi's empathy, one of the lecturers, showed that there was still a special need for research that had to be reported individually, even though within the same research team and a long reporting process made it late to report research.



Figure 5. Empathy map Lilis, S.T., M.M

The results of Lilis's (staff) empathy show the need for a system that can manage data collection so that research reporting can be stored properly so that in the process of output reporting for various purposes such as accreditation, performance achievements, performance evaluation will be made easier.

3.2 Define

The information gathering stage is taken from the empathize process by analyzing the observations and then synthesizing them to find the core problems that have been identified. This stage helps researchers collect ideas in building possible features, functions, and elements with the aim of solving problems that are experienced by users. Each of these parts is obtained from the user's empathy map in the previous process. The following is the stage of gathering information taken from the empathize process that has been carried out and created in the form of a user persona.

**Accounting Inquiries with New Approaches in the Post-Pandemic Era
Volume I**

	Prioritas Utama <ul style="list-style-type: none"> - Seluruh kinerja dapat dilaporkan secara lengkap dan sesuai dengan ketentuan yang berlaku 	Goal dan Motivasi <ul style="list-style-type: none"> - Terdapat sistem yang efektif dalam proses pelaporan, - Sistem yang memungkinkan pelaporan dilakukan per laporan penelitian bukan per dosen
Biografi Singkat	Personality <ul style="list-style-type: none"> - Manajemen - Administrasi pelaporan kinerja 	Kendala dan Tantangan <ul style="list-style-type: none"> - Sangat banyak kebutuhan administrasi yang harus dipenuhi, kemudian formulir pelaporan yang diisikan juga sangat banyak dan repetitif - Masing-masing dosen harus menginputkan sendiri
Nama: Dr. Budi Darmo, S.E., M.M.		
Umur: 42 tahun		
Pekerjaan: Dosen manajemen		
Lokasi Bekerja : Universitas Ciputra		

Figure 6. User Persona Dosen

	Prioritas Utama <ul style="list-style-type: none"> - Data yang ditarik merupakan data yang valid (tidak repetitif dan lengkap) - Pengelolaan data yang efektif dan efisien 	Goal dan Motivasi <ul style="list-style-type: none"> - Sistem informasi dapat membantu proses pelaporan data yang tidak repetitif dan juga pengelolaan data dapat dilakukan lebih efektif dan efisien.
Biografi Singkat	Personality <ul style="list-style-type: none"> - Administrasi database kinerja 	Kendala dan Tantangan <ul style="list-style-type: none"> - Banyaknya kebutuhan data ini tidak dibarengin dengan sistem informasi yang memadai, akhirnya data yang diberikan seringkali mengalami kesalahan seperti data yang repetitif - kebutuhan data masing-masing stakeholder juga memiliki template yang berbeda-beda, sehingga dalam proses pengelolaannya masih manual karena sistem belum dapat mengakomodir
Nama: Lilis, S.T., M.M.		
Umur: 35 tahun		
Pekerjaan: Staff LPPM		
Lokasi Bekerja : Universitas Ciputra		

Figure 7. User Persona Staff

3.3 Ideate

The results of the user persona at the define stage will be used to compile the user flow and flowchart of the research management information system as follows.

1. Userflow

Userflow is a diagrammatic depiction to find out user flow scenarios when accessing a website-based research management information system. The function of userflow is to make it easier for designers to determine flow before designing a website interface and avoid overly complicated system flows to make it easier for users/user friendly (Wulandari & Widiantoro, 2017).

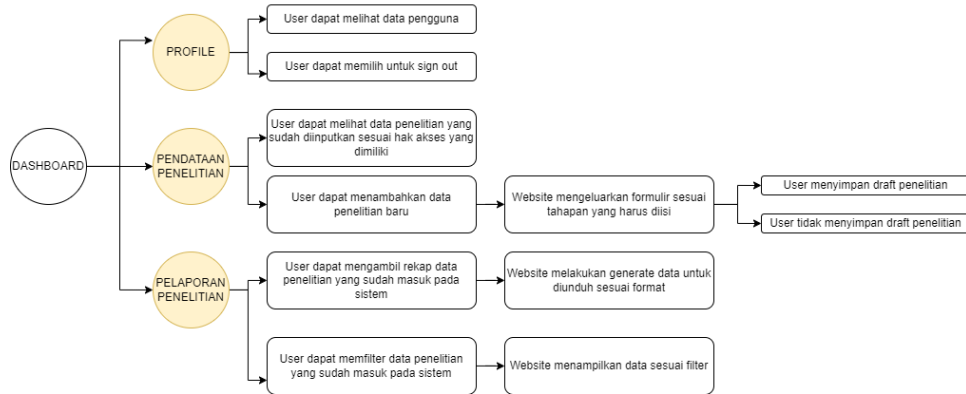

Figure 8. User flow proses ideate

2. Flowchart

Flowcharts have an important role in the research data management system. The main function of a flowchart is to help describe workflows and procedures in managing research data in a visual and structured manner. In the context of LPPM University research data management, a flowchart will help identify the steps that must be followed starting from adding research data, data management, approval to reporting.

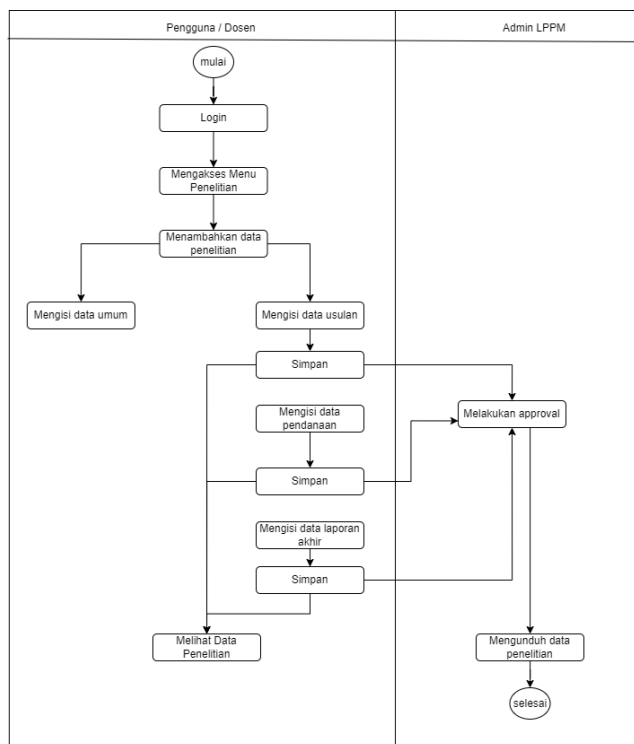

Figure 9. flowchart proses ideate

The results of this stage will be used as a validation stage for the user to ensure that the results of the system analysis and design will suit the user's needs. The method used for validation is to conduct group discussion forums with users who were previously interviewed at the

empathize stage so that users can identify if there are needs that have not been accommodated in the information system design. The number of users who participated in the FGD were five LPPM University staff by presenting the userflow and flowchart results above together with the predetermined question forms. The following is the contents of the question form that will be given to respondents before the FGD begins.

Table 1. FGD Guideline

No	Question	Yes	No
1.	Is the userflow easy to understand?		
2.	Is the flowchart or system flow in accordance with the current procedure?		
3.	Is the flowchart easy to understand?		
4.	Can the functions to be developed meet the needs in supporting the research data collection process?		
5.	Can the function to be developed meet the needs supporting the research reporting process?		

From the results of the FGD above, there are results that can be concluded as follows.

- a. All respondents answered 'Yes' to question number one (1)
- b. All respondents answered 'Yes' to question number two (2)
- c. There were 4 respondents who answered 'Yes' and 1 respondent answered 'No' for question number three (3)
 The comments given by respondents who answered no were: There is no description of the user's interaction with the system's reaction so that it is not understood at the beginning of the explanation. However, after going through the FGD process and explanation by the researcher, the flowchart is easy to understand.
- d. All respondents answered 'Yes' to question number four (4)
- e. All respondents answered 'Yes' to question number five (5)

3.4 Prototype

This stage is designing a prototype that displays the appearance of the system. Making a website display design according to the problems that have been found in the field. The results of the system design are adjusted to the existing dashboard as well as the addition of new features related to research management according to Figure. This design was made with the Balsamiq 3 application. In the prototype design it can be seen that this information system can be opened via a browser so that it is more responsive and easier to use on any device. Users do not have to open a PC/Laptop to access the system. However, the prototype design in this report is made with a display ratio on a computer or laptop.

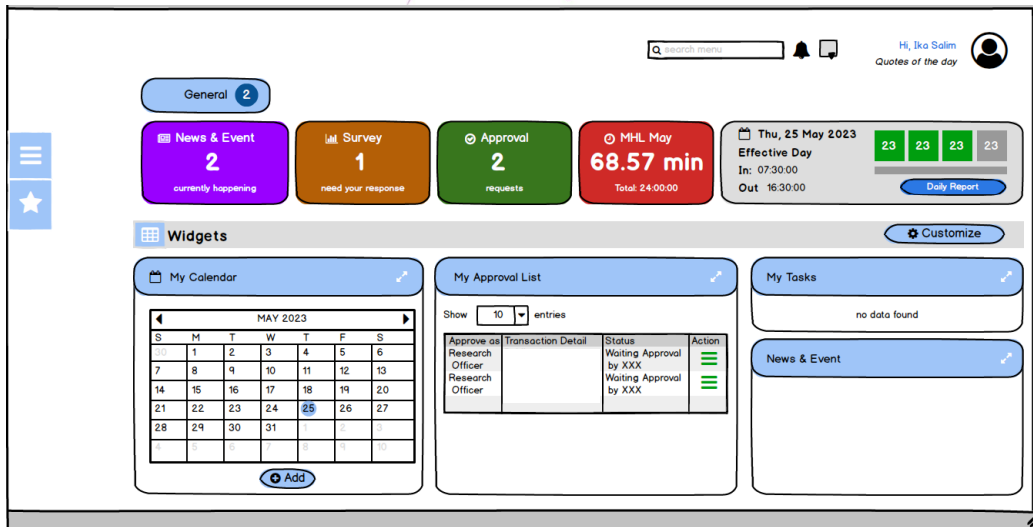

Figure 10. Dashboard Interface

Figure 10 is the main dashboard display of the system where the display reference is taken from the current system. Where researchers provide recommendations if the research data management system has the possibility to become part of an existing main system or can be developed into a separate system. In the dashboard display some important information appears that can be seen directly every time you access the system.



Figure 11. Menu Interface

Figure 11 is the display of the Menu Bar on the left and the 'Research' feature can be accessed easily through the menu. Users need to select the Menu Bar on the left then select Transaction > Research & Community Development > Research. In depicting this prototype, the researcher took references from users by using the display form that had been used earlier, namely the excel file.

Accounting Inquiries with New Approaches in the Post-Pandemic Era Volume I

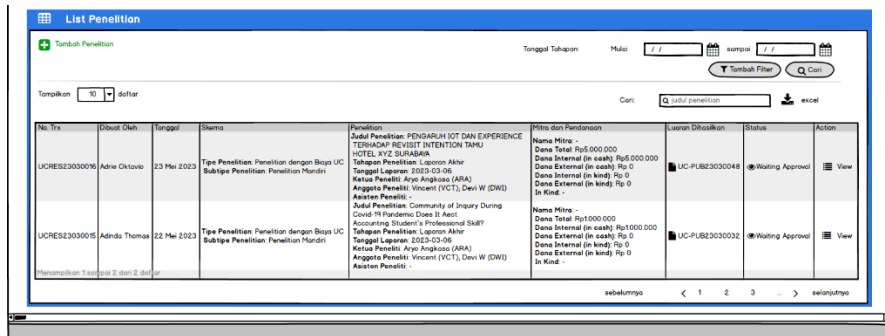

Figure 12. Research dashboard interface

Figure 12 shows the main dashboard view of the list of studies that have been entered into the system. There are several features related to Add Research, Research Filters, Search for certain Research, to Download Research Files in excel format. At the top, a menu bar is still displayed which makes it easier for users if they want to move to another transaction page or return to the system's main Dashboard.

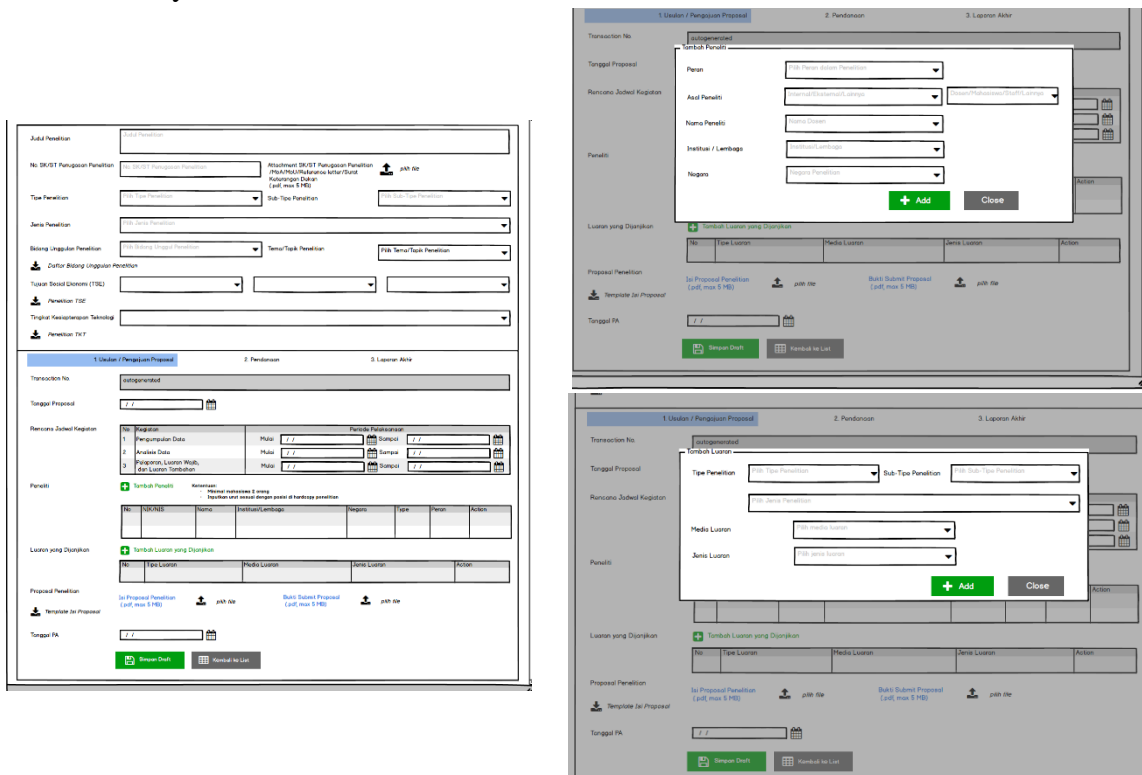

Figure 13. Research Proposal Interface

Figure 13 above shows the initial appearance of the research data form. In this menu the user can input research data. There are 2 different bars namely General Data and Detailed Data. The detailed data for this page includes the first page, namely 'Proposal'. There are two other views, namely Add Researcher and Add Output Type as different windows. When finished adding data the user can select 'Save Draft'. In depicting this prototype, the researcher took references from users by using the display form that had been used earlier, namely the excel file.



Figure 14. Research Funding Interface

Figure 14 above shows the same view in General Data. However, the detailed data for this page includes the second page, namely 'Funding'. There are two other views, namely Add Researcher and Add Output Type as different windows. When finished adding funding data the user can select 'Save Draft' or 'Submit Approval'. In depicting this prototype, the researcher took references from users by using the display form that had been used earlier, namely the excel file.

Figure 15. Research Final Report Interface

Figure 15 above shows the same appearance in General Data. However, the detailed data on this page includes the third page, namely 'Final Report'. There are two other views, namely Add Researcher and Add Output Type as different windows. When finished adding funding data the user can select 'Save Draft' or 'Submit Approval'. In depicting this prototype, the researcher took references from users by using the display form that had been used earlier, namely the excel file.

3.4.1 Evaluation

This stage is the result of the output after the testing process. In design thinking, the testing phase helps researchers to get user feedback so they can improve the design of ideas before they are used or developed further. This research accommodates changes according to the results of the feedback, namely related to the addition of file formats for downloading data on the LPPM research dashboard page. So that from the testing process the researcher returned to the prototype process to improve the appearance. This shows that the design thinking method supports processes that are iterative or iterative.

Figure 16 shows the same display in the LPPM research Dashboard data. However, based on the testing phase, there is input from users that can be accommodated, namely regarding the addition of the choice of file formats to be downloaded. The researcher added a 'download' function where if selected it will bring up a 'prompt' page to select the file format to be downloaded. The consideration for this change was accommodated by the researchers because of the overall input the 'export function' section had more than five respondents' suggestions while the other sections only amounted to two respondents.

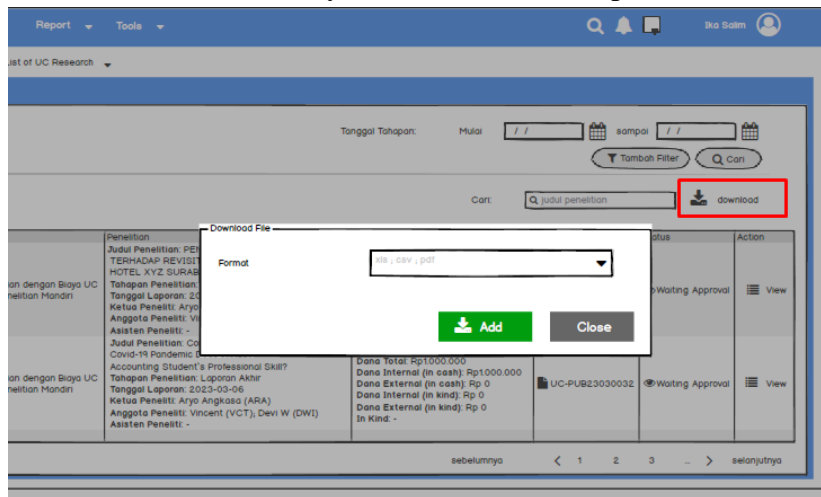

Figure 16. Fitur Development based on evaluation

3.5 Testing

The fifth stage of Design Thinking is testing the users. In the last stage of the design thinking process, researchers will conduct trials to get feedback and improve existing solutions and make products even better. Feedback from users is useful for knowing the strengths and weaknesses of the product so that improvements can be made (Ambrose & Harris, 2010). In this testing phase, the designer can make changes and improvements to rule out solutions to problems and gain the deepest possible understanding of the product and its users.

The technique for determining the number of samples, this study uses Green (1991):

$$Sample = 50 + 8 (n)$$

$$Sample = 50 + 8 (1)$$

$$= 58$$

n = variable yang digunakan

In this study, only one variable was used, namely the display of the information system. Thus, researchers distributed questionnaires and obtained a sample of 60 respondents.



This assessment uses a Likert scale, which is a method used in surveys to measure respondents' attitudes or opinions towards certain statements or statements (Rensis Likert, 1932). The feedback obtained from the User Perception Survey activities has received good results from website users.

Based on the questions given, the results are in accordance with Table 2.

Tabel 2. Testing Question

No	Question	Scale					Total	
		5	4	3	2	1		
Dashboard								
1.	Based on figure 1, how easy is it to access search the research menu?	25	34	1			60	
Research list dashboard								
2.	Is the display of the research dashboard list informative?	21	38	1				
Research Proposal Interface								
3.	Is the display for filling in the proposal easy understand?	23	35	2				
4.	Can filling out the form above (proposal section) be filled easily?							
5.	Is the data entered in the proposal repetitive? Yes= 6; No=54							
6.	How compatible are the proposal fields with the external platform reporting fields? (External platforms: SINTA, SISTER, and BIMA)	24	34	2				
Research Funding Interface								
7.	Is the funding filling display easy to understand?	20	39	20				
8.	Can filling in the form above (funding section) be filled easily?	19	41					
9.	Is the data entered in the proposal repetitive? Yes= 6; No=54							
10.	How do the funding fields match the external platform reporting fields? (External platforms: SINTA, SISTER, and BIMA)	21	37	2				
Research Final Report Interface								
11.	Is the appearance of filling in the final report easy to understand?	25	34	1				
12.	Can filling in the form above (final report section) be filled easily?	24	35	1				
13.	Apakah data yang diinputkan pada laporan akhir repetitif? Ya= 6; Tidak=54							
14.	How do the contents of the final report match those of the external platform reporting? (External platforms: SINTA, SISTER, and BIMA)	22	35	3				

Information:

Unsuitable = 1; Unsuitable = 2; Fairly Match = 3; Match = 4; Very suitable = 5.

The conclusions that researchers get from the results of open questions given through online surveys are as follows:

- Display is good and easy to fill 21
- Add format 'Export' files 5
- Need to be realized for trial 4
- Display made simpler 2
- Language consistency in the system 2

Further analysis was carried out by the researchers and it was determined that the prototype design made in Balsamiq 3 by the researchers would undergo revision so that there would be improvements in the export files configuration section on the LPPM main Dashboard page. The results of display improvements related to the export configuration can be seen in section 4.4 Prototype in the evaluation results section. Then from all the results of this prototype, the researcher will submit the results to the Ciputra University ICT department for further development.

CONCLUSION

The Design Thinking method in website design can be used to produce an information system design that fits the needs of its users. This can be seen from user feedback, namely the results of the User Perception Survey (testing) stage of sixty participants who are prospective system users and LPPM administration staff in the field of research regarding the appearance of system design are good. The conclusions that can be drawn from the results of research related to "**Research Reporting and Data Collection Information System Design at Ciputra University Surabaya with the Design Thinking Method**" are as follows:

1. The design of the information system has a simple user interface and includes the functions needed to make it easier for lecturers in the process of inputting research data.
2. The design of the information system that is made has options in extracting data as needed so that the process of withdrawing and managing research data will be more effective and efficient.

This study has important implications for theory and practice in creating a good user-oriented information system design. This study shows that design thinking provides understanding to institutions regarding problem analysis of system users, especially staff and educators, user needs, creating solutions and how products can be well received by potential users.

SUGGESTION

The stages in Design Thinking can be done repeatedly to get the best design results for its users and the empathize stage is the stage that really determines the concept and design of information systems. So, it is better at this empathize stage that observations, interviews and other elicitation processes can be carried out in depth to explore all user needs in order to provide useful input for system developers. In addition, the solutions developed provide comfort and security for users when accessing the website.

In this research at the testing stage there are open questions. Referring to the results, the researcher hopes that in future studies the design of this research management information



system will pay more attention to the language used in the system and a high-fidelity prototype can be developed.

REFERENCES

- Research.com. (2023), History of eLearning: Evolution from Stenography to Modern LMS Platforms. Diakses pada 02 Maret 2023, dari [research.com/education/history-of-elearning#:~:text=In%201999%2C%20Researcher%20and%20Educator,education%20\(Keegan%2C%202020\)](https://research.com/education/history-of-elearning#:~:text=In%201999%2C%20Researcher%20and%20Educator,education%20(Keegan%2C%202020).).
- Marinoni, G., & van't Land, H. (2020). The impact of COVID-19 on global higher education. *International higher education*, (102), 7-9.
- Zawacki-Richter, O. (2021). The current state and impact of Covid-19 on digital higher education in Germany. *Human Behavior and Emerging Technologies*, 3(1), 218-226.
- Pauziah, U. (2022). PERANCANGAN SISTEM INFORMASI BISNIS CENTER DI SMK FATAHILLAH CILEUNGSI. *Sentri: Jurnal Riset Ilmiah*, 1(1), 223-232.
- Laudon, K. C., & Laudon, J. P. (2004). *Management information systems: Managing the digital firm*. Pearson Educación.
- Osterwalder, A., Pigneur, Y., Oliveira, M. A. Y., & Ferreira, J. J. P. (2011). Business Model Generation: A handbook for visionaries, game changers and challengers. *African journal of business management*, 5(7), 22-30.
- Osterwalder, A. (2004). *The business model ontology a proposition in a design science approach* (Doctoral dissertation, Université de Lausanne, Faculté des hautes études commerciales).
- Puspita, Niniek F. (2023), *Design Thinking, Bahan Kuliah: Manajemen Teknologi dan Inovasi, Sekolah Interdisiplin Manajemen dan Teknologi, Institut Teknologi Sepuluh Nopember, Surabaya*.
- Plattner, H., Meinel, C., & Leifer, L. (Eds.). (2010). *Design thinking: understand–improve–apply*. Springer Science & Business Media.
- Sari, I. P., Kartina, A. H., Pratiwi, A. M., Oktariana, F., Nasrulloh, M. F., & Zain, S. A. (2020). Implementasi Metode Pendekatan Design Thinking dalam Pembuatan Aplikasi Happy Class Di Kampus UPI Cibiru. *Edsence: Jurnal Pendidikan Multimedia*, 2(1), 45-55.
- Taufik, Tatang A. (2023), *Perancangan Inovasi Dengan Design Thinking, Bahan Kuliah: Manajemen Teknologi dan Inovasi, Sekolah Interdisiplin Manajemen dan Teknologi, Institut Teknologi Sepuluh Nopember, Surabaya*.
- Wibowo, M. R., & Setiaji, H. (2020). Perancangan Website Bisnis Thrifdoor Menggunakan Metode Pendekatan Design Thinking. *AUTOMATA*, 1(2).
- Wulandari, W., & Widiyanto, A. D. Y. (2017). Design data flow diagram for supporting the user experience in applications. *Design Data Flow Diagram for Supporting the User Experience in Applications*, 25(2), 14-20.
- Marthasari, G. I., Risqiwati, D., & Dewi, T. B. T. (2017). Rancang bangun dan implementasi website e-commerce ukm gs4 malang menggunakan metode prototyping.
- Karnawan, G. (2021). Implementasi User Experience Menggunakan Metode Design Thinking Pada Prototype Aplikasi Cleanstic. *Jurnal Teknoinfo*, 15(1), 61-66.
- Albert, B., & Tullis, T. (2013). *Measuring the user experience: collecting, analyzing, and presenting usability metrics*. Newnes.
- Dalis, S. (2017). Rancang Bangun Sistem Informasi Lembaga Penelitian Dan Pengabdian Masyarakat Berbasis Web. *Paradigma*, 19(1), 1-8.
- Ambrose, G., & Harris, P. (2009). *Basics design 08: design thinking*. Bloomsbury Publishing.
- Green, S. B. (1991). How many subjects does it take to do a regression analysis. *Multivariate behavioral research*, 26(3), 499-510.
- Likert, R. (1932). A technique for the measurement of attitudes. *Archives of psychology*.

CHAPTER 21

The Impact of Heat waves on Food Security and The Role of International Environmental Law

Amalia ZUHRA

Universitas Trisakti, Indonesia
amalia.z@trisakti.ac.id
Orcid: 0000-0001-7481-9244

Arlina PERMANASARI

Universitas Trisakti, Indonesia
arlina.p@trisakti.ac.id
Orcid: 0000-0002-6564-3870

Siti Hafyah IDRIS

Universiti Teknologi Mara, Malaysia
sitihafsyah@uitm.edu.my
Orcid: 0000-0002-6480-3828

Mr. Muhammad Falih NASYWAAN

Universitas Trisakti, Indonesia
Muhammadfalih01@gmail.com
Orcid: 0009-0009-9794-3649

ABSTRACT

Asian countries faced unprecedented heatwaves in 2023, with temperatures reaching up to 51.2 degrees Celsius in the city of Kumarkhali, Bangladesh, in April 2023. This article will discuss the connection between climate change and heatwaves, the triggering factors of heat waves, and their impact on food security especially in Asian countries. Furthermore, it will outline the framework of international environmental law in addressing the challenges of heat waves. The purpose of this article is to provide input for policymakers in issuing regulations related to the impact of heat waves on food security in Asian countries. This article is a normative research conducted through literature review using secondary data. The article concludes that heatwaves pose a real threat to food security, primarily due to disruptions in food crop and livestock production. They also cause economic losses and food supply instability. International environmental law plays a crucial role in addressing the impact of heatwaves on food security, particularly in protecting agricultural ecosystems and biodiversity, as well as ensuring sustainable water resource management and irrigation. This article discussed heatwaves in numerous Asian countries and other parts of the world in 2023 post-COVID-19 pandemic situation, where there is still limited literature discussing this phenomenon in relation to food security.

Keywords: Heat waves, Food security, Climate change, International environmental law, Sustainable agriculture



INTRODUCTION

Heat waves are prolonged periods of abnormally hot weather, typically lasting several days or weeks. According to several studies, they are becoming more frequent, intense, and longer-lasting due to climate change (Meehl and Tebaldi, 2004; Perkins et al., 2012; Perkins-Kirkpatrick and Lewis, 2020). The studies also provide statistics on recent heat waves around the world. For example, the unprecedented heat waves in the Yangtze River Valley and Asia in general in 2022 (Ma and Yuan, 2023) and the extreme heat waves in Australia in 2019-2020 (Reddy et al., 2021). The studies highlight the impacts of these heat waves on the environment and human beings, including droughts, wildfires, crop failures, and health impacts such as heat exhaustion and dehydration. The studies suggest that heat waves are a significant and growing threat to the world's population and ecosystems. The statistics on recent heat waves underscore the urgent need for action to address climate change and mitigate its effects.

There are several studies and articles that discuss the unprecedented heat waves that occurred in the Yangtze River Valley and Asia in general in 2022. The studies explore the causes and impacts of these heat waves, as well as their relationship to climate change and other atmospheric phenomena. One study by Luo and Lau (2020) suggests that summer heat extremes in northern continents, including Asia, are linked to developing El Niño-Southern Oscillation (ENSO) events. Another study by Luo et al. (2022a) examines the propagation patterns of spatiotemporally contiguous heat waves in China. In contrast, a third study by Luo et al. (2022b) contrasts the circulation patterns of dry and humid heat waves over southern China. Ma and Yuan (2023) investigate when the unprecedented 2022 summer heat waves in the Yangtze River basin will become normal in a warming climate. Meanwhile, Zhang et al. (2023) explore why the heatwave in the Yangtze River valley was abnormally intensified in late summer 2022. Other studies in the document examine the relationship between Arctic warming and East Asian hot summers (Kim et al., 2022), the impact of diabatic heating over the Indian subcontinent on heat waves in South Korea (Kim et al., 2019), and the dominant modes of sub-seasonal variability of East Asian summertime surface air temperature (Liang et al., 2018). Overall, the studies in the document suggest that the unprecedented heat waves in the Yangtze River Valley and Asia in general are likely linked to a combination of factors, including ENSO events, Arctic warming, and sub-seasonal variability of surface air temperature. The studies also highlight the urgent need for further research and action to address the impacts of climate change on extreme weather events.

The impact of heat waves on the environment and human beings can be severe. Heat waves can cause droughts, wildfires, and crop failures, leading to food shortages and economic losses. They can also lead to the degradation of ecosystems, including coral reefs and forests. In addition, heat waves can have serious health impacts on human beings, including heat exhaustion, heatstroke, and dehydration. Vulnerable populations, such as the elderly, children, and those with pre-existing health conditions, are particularly at risk. Heat waves can also

exacerbate air pollution and increase the risk of infectious diseases. Overall, the impact of heat waves on the environment and human beings highlights the urgent need for action to address climate change and mitigate its effects. (Boqi Liu, 2023)

As global temperatures continue to rise due to increasing CO₂ emissions, heat waves are becoming more common and lasting longer. Many parts of the world will experience hot weather in excess of 40 degrees Celsius by 2060. Without more aggressive emission reductions, many people living in the tropics will be exposed to dangerous heat index values on most days of the year by 2100. Changing environmental conditions are increasing the suitability for the transmission of water-borne, air-borne, food-borne, and vector-borne pathogens, which can spread infectious diseases. Climate change is leading to closer and more widespread contact between wildlife and humans, thereby promoting the occurrence and spread of new infectious diseases. (Xinbo Lian, 2023). There is no direct connection of food security and heat waves. However, climate change can significantly impact food security, such as changes in crop yields, water availability, and food prices. (Xinbo Lian, 2023).

Climate change threatens food security and nutrition by influencing the environment and humans. Agricultural production declines, reduced wages, growing food safety challenges, and disruptions in food distribution are all effect pathways from climate change to poverty and malnutrition. Climate change can create heat stress, modify phenology, and change the environment for pests and diseases, including the rapid spread of mycotoxins and infections. Floods, droughts, storm surges, and extreme events with increased frequency and intensity can cause significant disruptions in food supply chains due to crop failures and infrastructure damage and promote rivalry among food production systems. (Alisher Mirzabaev, 2023)

Heat waves, droughts, and floods can impact people's food security, health, and nutrition and diminish their productivity, harming their livelihoods and incomes, especially for those working in climate-sensitive industries or outside. This vulnerability can significantly impact more vulnerable low- and middle-income countries, those that rely on rainfed agriculture, and certain social and economic groups such as smallholder farmers and farmworkers, low-income households, the elderly, women, and children. The severity of the risk of climate change on the number of hungry people worldwide is determined by the timing of these impacts. The ability to respond to these repercussions varies according to the GHG emissions degree and the related shared socioeconomic pathways (SSPs) features. (Alisher Mirzabaev, 2023)

Extreme occurrences such as heat waves, floods, droughts, pest outbreaks, diseases, financial crises, and human conflicts are becoming more common and threaten global food production and supply. These occurrences can reduce the availability and access to excellent and nutritious food, resulting in cascade and systemic effects that are difficult to forecast, plan for, and prepare for. Many of these concerns are rooted in unresolved governance difficulties in international relations, and coordinated research is required to assist develop and implementing governance structures for food systems that are resilient to extreme occurrences in the future.



There are many studies on the connection between climate change and food security. Several studies and reports from organizations such as the Food and Agriculture Organization (FAO) and the Intergovernmental Panel on Climate Change (IPCC) have examined the impacts of climate change on food security. Additionally, there are numerous academic articles and research reports that have explored this topic from various angles, including the effects of climate change on crop yields, food prices, and food distribution systems, as well as the social and economic factors that contribute to vulnerability to food insecurity in the face of climate change. (Alisher Mirzabaev, 2023)

According to Datta, 2023, several studies examined the impact of climate change on Indian agriculture. Some of the studies suggest that climate change is likely to have a negative impact on Indian agriculture, including increased vulnerability to extreme weather events such as heat waves and droughts, changes in precipitation patterns, and changes in pest and disease patterns. These impacts could potentially affect food security in India, as agriculture is a major source of livelihood and food for many people in the country. (Dhanya, 2016) However, the studies also suggest that there are opportunities for adaptation and mitigation strategies that could help to reduce the negative impacts of climate change on Indian agriculture. (Rickards, 2012)

Several research questions will be discussed in this chapter.

1. What is the relationship between climate change and heat waves, and how do heat waves affect Asian food security?
2. What variables cause heat waves in Asian countries, particularly in the context of unprecedented heat waves in 2023?
3. What role does international environmental law play in addressing the problems and consequences of heat waves for food security?
4. How can policymakers use the study's findings to improve legislation and policies concerning the impact of heat waves on food security?

The objectives of this chapter are:

1. To investigate the relationship between climate change and heat waves and the implications for Asian food security.
2. To investigate the mechanisms that cause heat waves in Asian countries, emphasizing the extreme heat waves that occurred in 2023.
3. To analyse the role of international environmental legislation in addressing the issues raised by heat waves and their impact on food security.
4. To provide policymakers with insights and recommendations based on the study's findings for creating appropriate regulations and policies to limit the effects of heat waves on Asian food security.

5. To add to the current literature by investigating the phenomenon of heat waves concerning food security in the post-COVID-19 era, when there has been little research on this topic.

1. LITERATURE REVIEW

1.1 Climate Change And Its Relationship With Heat Waves

Climate change is a threatening phenomenon in this modern era since 1950, reported by the IPCC Working Groups (Marx, 2021). This phenomenon triggers several changes on Earth, including the increase in sea levels and high temperatures (extreme weather events), specifically the occurrence of heat waves in Europe, Asia, and Australia (Marx, 2021). It has been proven that there is a reciprocal relationship between heat waves and climate change, where heat waves may be impacted by climate change or climate change may intensify heat waves, making them more dangerous (Puley G, 2022). This is an example of how climate change and heat waves have a strong relationship which poses a severe threat to human health and environmental ecosystem.

1.2 Triggering Factors Of Heat Waves In Asian Countries

In recent 2023, several significant events of the heat waves impacted India, China, Thailand, and Laos (Chi Hui Lin, 2023). In common research, the primary factor contributing to heat waves in Asia is the temperature threshold ranging between 40 to 45 °C (Sharma, 2022). Therefore, it can be inferred that temperature is the primary factor driving heat waves worldwide.

1.3 Impacts Of Heat Waves On Food Security

Heat waves have a negative impact on human health, the environment, and the agricultural sector. Significant research has found that food security, which is crucial for basic human needs, can be influenced by heat waves (Alisher Mirzabaev, 2023). It is important to note that heat waves also have a negative impact on food security (Sanobar N., 2023). For instance, the Indian Government banned wheat export in response to the unprecedented heatwave in May 2022 to ensure food system security for its citizens (Kroeger, C., & Reeves, A., 2022).

1.4 Existing Studies On The Role Of International Environmental Law In Addressing Climate Change Impacts

Given the strong connection between heat waves and climate change, international environmental law provides a legal framework to reduce Earth's temperature and prevent adverse impacts from climate change. It was enshrined in The United Nations Framework Convention on Climate Change (UNFCCC) regime, along with instruments such as the Kyoto Protocol and the Paris Agreement, legally bind almost all United Nations Member States (Ranjamani, L., Peel J., 2021). Additionally, customary international law plays a role in achieving the same purpose (Benoit Mayer, 2023).



2. METHODOLOGY

The methodology employed in this article is a library research approach, which uses secondary data sources related to heat waves and food security. The data is analysed through a qualitative approach, and conclusions are drawn using the deductive reasoning method. This methodology aims to explore the current state of the heat waves and its impact on food security. By analysing existing literature, this research aims to identify gaps in international laws and regulations related to heat waves and its impact on food security. Specifically, the article aims to; first investigate the relationship between climate change and heat waves and the implications for Asian food security. Secondly, to investigate the mechanisms that cause heat waves in Asian countries, emphasizing the extreme heat waves that occurred in 2023. Thirdly, this book chapter will analyse the role of international environmental legislation in addressing the issues raised by heat waves and their impact on food security. Finally, this article will provide policymakers with insights and recommendations based on the study's findings for creating appropriate regulations and policies to limit the effects of heat waves on Asian food security. Then, this book chapter aims to add to the current literature by investigating the phenomenon of heat waves concerning food security in the post-COVID-19 era, when there has been little research on this topic.

3. HEAT WAVES AND FOOD SECURITY IN ASIAN COUNTRIES

3.1 Overview Of Heat Waves In Asian Countries In 2023

Heat waves have become a severe worry in Asian countries in recent years, posing considerable challenges to human health, agriculture, and the environment. The frequency, duration, and severity of these extreme weather events, marked by prolonged periods of intense heat, have increased. This article overviews Asian heat waves, including essential statistics, current examples, and the underlying reasons.

Extensive meteorological data show a concerning pattern of growing heat waves in Asian countries. The number of heatwave days per year has more than doubled in the last decade compared to earlier decades. This trend is evident in India, China, Japan, and Southeast Asian countries. Rising temperatures and more frequent heat waves endanger the health of people all over the world. Several recent incidents demonstrate the severity and impact of Asian heat waves. India endured one of its deadliest heat waves in 2022, with temperatures reaching 50 degrees Celsius in some areas. This intense event caused many heat-related deaths and greatly strained public health systems and infrastructure. Similarly, Japan experienced a terrible heatwave in 2019, smashing temperature records and resulting in increased heatstroke cases and a tragically high number of deaths.

Heat waves in Asian countries are caused by global climate change and regional weather patterns. Increased greenhouse gas emissions and resultant global warming lead to global temperature rise. Due to its particular conditions, Asia is subject to extra elements that enhance the severity of heat waves. Rapid urbanization, deforestation, and air pollution

enhance the heat island effect, resulting in isolated heat waves in highly populated cities. Furthermore, the El Niño-Southern Oscillation (ENSO) phenomenon, which affects Pacific Ocean sea surface temperatures, might alter weather patterns and contribute to the occurrence of heat waves in the region. ENSO, refers to a naturally occurring climate phenomenon that occurs in the tropical Pacific Ocean. It is characterized by the periodic warming and cooling of ocean surface temperatures, along with changes in atmospheric pressure patterns (Subash, 2023)

Heat waves have far-reaching implications in Asian countries, affecting civilization and the environment. Human health is particularly jeopardized, with vulnerable populations such as the elderly, children, and those with pre-existing medical disorders particularly vulnerable. Heat-related disorders, such as heat stroke, dehydration, and respiratory problems, become more common during extended heat waves. Because of the burden on healthcare systems and the risk of loss of life, thorough heatwave readiness and response measures are required.

Heat waves also harm agricultural systems, resulting in lower crop yields, livestock losses, and higher water demand for irrigation. Agriculture is a crucial economic sector and a primary source of income for millions of people in Asian countries. Asian countries heavily rely on agriculture as a vital economic sector and a primary source of livelihood for millions of people. Heat stress affects crop growth and development, leading to lower-quality produce and potential crop failures. The scarcity of water resources exacerbates these challenges, further compromising food security in the region.

Beyond the immediate impacts on society and agriculture, heat waves in Asian countries also harm the environment. These extreme weather events contribute to the melting of glaciers, the drying up of water sources, and the degradation of ecosystems. The ecological balance is disrupted, with implications for biodiversity, natural habitats, and overall environmental sustainability.

Given the increasing frequency and intensity of heat waves in Asian countries, it is critical to take preventive measures to limit their effects. Governments, communities, and individuals must prioritize policies and measures to reduce greenhouse gas emissions, address climate change, and prepare for heat waves. Implementing heat emergency response plans, enhancing urban planning to reduce the heat island effect, and implementing sustainable agricultural practices are all critical steps toward increasing resistance to heat waves.

Investing in research and technology improvements can also help to control heat waves more effectively. Developing heat-tolerant crop types, improving water resource management, and improving early warning systems are critical for reducing agricultural losses and ensuring food security. International collaborations and knowledge-sharing platforms are critical in promoting the exchange of expertise, experiences, and best practices in dealing with heat waves and their consequences.



Heat waves are an increasing hazard to human health, agriculture, and the environment in Asian countries. Statistics and current occurrences show that the frequency and intensity of these extreme weather events are growing. Global climate change, regional weather patterns, and local circumstances are all contributing factors. To protect vulnerable populations, protect agricultural systems, and preserve the environment, immediate action is essential to address heatwave concerns, including mitigation and adaptation strategies. Asian countries can build resilience and secure a more sustainable future in the face of growing heat waves by responding collaboratively to this vital issue.

3.2 Impact Of Heat Waves On Food Crop Production

Agriculture is one of the most important sectors contributing to a country's economy and food security. As the climate continues to change and heat waves become more frequent and severe, it is becoming increasingly clear that crop productivity will be impacted. Research has shown that global warming is causing more extreme and frequent heat waves, which are particularly damaging to crop productivity. These heat waves have been linked to lower yields in food crops, with the primary cause of yield reduction being the impairment of plant reproductive systems. (Grusson & Barron, 2022) Therefore, to ensure food security and mitigate the effects of climate change on crop yields, there is a need for a fundamental understanding of how heat stress affects plant reproduction.

Water scarcity, severe droughts and extreme temperatures have also contributed to the decline in crop productivity and economic yields from agricultural land, thereby affecting food security. The recent worst heatwave due to global warming is threatening water supplies, while China and Europe have been facing severe droughts in recent years (Mahreen et al., 2023). Moreover, as global warming progresses, crop yields worldwide are also at risk (Zhang et al., 2021). High temperatures resulting from global warming affect both plant vegetative and reproductive growth, leading to decreased productivity and quality of crop products (Zhang et al., 2021). To combat the adverse effects of heat waves on crop yields, there is a need to understand the complex events that occur when plants are subjected to heat stress. Plants respond to heat stress by activating a suite of complex events, including various signalling pathways, changes in the expression of genes in different regulatory networks and a cascade of physiological and biochemical processes (Zhang et al., 2021). This understanding can guide breeding strategies toward generating climate change-resilient crops. In conclusion, the impact of heat waves on food crop production has become a significant concern for researchers and policymakers alike. As agriculture and food production are some of the most critical sectors in contributing to a country's economy and food security, it is imperative that we address the challenges posed by climate change and develop effective strategies to mitigate its effects on crop productivity.

The vulnerability of plant reproduction to high-temperature stresses during early reproductive development is a critical area for future research. Researchers need to focus on this aspect to

thoroughly understand the mechanisms involved and develop effective countermeasures. Furthermore, as global climate analysis predicts that high temperatures will become more frequent shortly, we must take action to address this issue.

This could include implementing sustainable farming practices, investing in climate-resilient crop breeding programs and developing robust weather monitoring systems to predict heatwave events.

3.3 Effect Of Heat Waves On Livestock Production And Animal Health

Effect of Heat waves on Livestock Production and Animal Health Introduction Heat waves have become increasingly common in recent years, bringing myriad challenges for various sectors, including agriculture and livestock production. These extreme heat events pose a significant threat to livestock production and animal health, with far-reaching consequences for both farmers and the broader economy (Prathap et al., 2021). Livestock production and animal health are intricately linked to environmental conditions, and heat waves can devastate both. Livestock, just like humans, can experience heat stress when exposed to prolonged periods of excessively high temperatures. This can lead to a range of physiological consequences, including reduced feed intake, decreased milk production, poor reproductive performance, and even death in extreme cases. Heat stress in livestock can occur when the animal's body cannot regulate its internal temperature effectively. (Hubbard et al., 2018). This can result in increased respiration rates, elevated heart rates, and decreased overall productivity. Research has shown that heat waves can have a negative impact on livestock production in multiple ways (Chisanga et al., 2022). Firstly, heat waves can directly affect the productivity of livestock by reducing feed intake. During heat waves, animals may consume less food due to decreased appetite or feed availability. This can lead to a decline in body condition and weight gain, ultimately affecting the profitability of livestock operations. Additionally, heat waves can also disrupt the reproductive cycle of livestock. High temperatures during heat waves can impair animal reproductive processes, including decreased fertility rates and increased embryonic mortality. Furthermore, heat stress can also compromise the immune system of livestock, making them more susceptible to diseases and infections. Studies have shown that heat stress weakens the immune response in animals, making them more vulnerable to various diseases. In addition to the direct effects on livestock, heat waves indirectly impact animal health and production (Chisanga et al., 2022). For instance, heat waves can change the availability and quality of water sources for livestock.

Water sources can dry up or become contaminated during heat waves, increasing the risk of dehydration and waterborne diseases in livestock. Livestock owners must take proactive measures to mitigate the adverse effects of heat waves on their animals. This includes implementing strategies such as providing shade and ventilation, ensuring access to clean and cool water at all times, adjusting feeding schedules to cooler periods of the day, and monitoring the health and behaviour of animals closely. The combined effects of heat waves



on livestock production and animal health are significant. They impact the immediate productivity and profitability of livestock operations and have long-term consequences for animal welfare and overall sustainability. (Hubbard et al., 2018) The well-being and productivity of livestock are intricately linked to the effects of heat waves. Livestock owners and producers must recognize the potentially detrimental effects of heat waves on their animals and take proactive measures to mitigate these impacts.

The negative impact of heat waves on livestock production and animal health goes beyond the immediate consequences. (Mirzabaev et al., 2023) Heat waves can have long-term effects on livestock's reproductive capacity and genetic potential. Repeated exposure to heat stress can decrease the fertility rates of livestock, affecting their ability to reproduce and maintain healthy herd populations. Additionally, heat stress can lead to genetic changes within livestock populations over time. These changes may decrease resistance to heat stress and other environmental challenges, making livestock more susceptible to disease and reduced productivity. Furthermore, heat waves can exacerbate the spread of diseases among livestock. Livestock experiencing heat stress have a weakened immune system, making them more susceptible to various pathogens and diseases. This increased vulnerability to diseases can lead to outbreaks and epidemics within livestock populations, further compromising their health and productivity. Heat waves pose a significant threat to livestock production and animal health. The direct effects of heat stress on livestock are well-documented and include altered feed intake, mortality, growth, reproduction, maintenance, and production. (Kadzere, 2018) However, the indirect effects of heat waves on livestock production and animal health are equally concerning. Not only does heat stress directly impact the physiological well-being of livestock, but it also has cascading effects that extend to their overall productivity and reproductive capacity. Livestock farmers must be proactive in implementing effective strategies to mitigate the adverse effects of heat waves on their animals.

In order to mitigate the adverse effects of heat waves on livestock production and animal health, it is essential for livestock farmers to implement proactive measures. Providing shade and shelter, ensuring access to clean and cool water, improving ventilation in livestock housing, and utilizing cooling systems are vital strategies that can help alleviate the impact of heat stress on animals. (Muthee et al., 2022) By creating a conducive environment for the animals, farmers can minimize the physiological and behavioural changes associated with heat stress. These measures can help maintain adequate feed intake, promote efficient metabolism, and reduce the risk of diseases and mortality. Furthermore, adjusting management practices and feeding strategies during heat waves is crucial.

3.4 Economic Losses And Food Supply Instability Due To Heat Waves

Heat waves have emerged as a significant concern in recent years due to their profound impact on the global economy and food supply. These anomalous episodes of extremely high surface air temperatures, lasting for several days, result in economic losses and food supply instability. The consequences of heat waves are far-reaching and affect various sectors,

including health, agriculture, ecosystems, and the national economy. When it comes to the agricultural sector, heat waves have detrimental effects on crop and livestock production. (Haile et al., 2018)

Crop yields are significantly reduced during heat waves due to increased evaporation, which leads to soil moisture depletion and drought conditions. This reduction in crop yields results in lower agricultural output, leading to economic losses for farmers and decreased food supply availability. Additionally, heat waves can also lead to the loss of livestock due to heat stress and inadequate feed availability. As a result, the agricultural sector faces financial burdens and struggles to meet the demands of the population. (Kumari et al., 2020)

4. INTERNATIONAL ENVIRONMENTAL LAW AND ITS ROLE IN ADDRESSING HEATWAVE IMPACTS

4.1 Framework Of International Environmental Law Related To Climate Change And Heat Waves

International environmental law provides a framework for addressing heatwave impacts on food security. The following are some key international legal instruments and principles relevant to this issue:

1. United Nations Framework Convention on Climate Change (UNFCCC)

The UNFCCC is a treaty aimed at stabilizing greenhouse gas concentrations in the atmosphere to prevent dangerous anthropogenic interference with the climate system. The convention acknowledges the importance of food security and emphasizes the need to promote sustainable agricultural practices and enhance resilience to climate change impacts, including heat waves.

2. Paris Agreement

The Paris Agreement is an international treaty under the UNFCCC that aims to limit global warming to well below 2 degrees Celsius above pre-industrial levels. It recognizes the importance of safeguarding food security and promotes adaptation measures to address climate change's adverse impacts on agriculture, including heat waves. The agreement also emphasizes the role of sustainable land management and resilient agricultural practices.

3. Convention on Biological Diversity (CBD)

The CBD is an international treaty that aims to conserve biodiversity, ensure its sustainable use, and promote fair and equitable sharing of benefits derived from genetic resources. Biodiversity is crucial in supporting food security and enhancing ecosystem resilience to climate change impacts. Protecting and restoring biodiversity through measures outlined in the CBD can contribute to mitigating the impacts of heat waves on agricultural systems.

4. International Treaty on Plant Genetic Resources for Food and Agriculture (ITPGRFA)

The ITPGRFA is a treaty that promotes the conservation and sustainable use of plant genetic resources for food and agriculture. It recognizes the importance of genetic diversity in



maintaining resilient agricultural systems. The treaty encourages international cooperation to ensure that plant genetic resources are available for breeding programs that develop heat-tolerant crop varieties, which can help mitigate the impacts of heat waves on food security.

5. International Covenant on Economic, Social, and Cultural Rights (ICESCR)

The ICESCR is a human rights treaty that recognizes the right to an adequate standard of living, including the right to food. States parties to the ICESCR are obliged to take measures to ensure access to food for all individuals, including in times of emergency and crisis. Heat waves can threaten food security, and the ICESCR provides a legal basis for states to protect and fulfil the right to food during such events.

6. Precautionary Principle

The precautionary principle is a fundamental principle of international environmental law that guides decision-making in the face of scientific uncertainty. It emphasises the need to take preventive measures when there are threats of serious or irreversible environmental or human health damage. In the context of heat waves and food security, the precautionary principle calls for proactive actions to reduce greenhouse gas emissions, promote climate resilience, and protect vulnerable populations from the adverse impacts of heat waves.

4.2 Protection Of Agricultural Ecosystems And Biodiversity

The legal perspective on heatwaves and protecting agricultural ecosystems and biodiversity is complex and evolving. There are a number of international agreements that address these issues, but there is no single, comprehensive legal framework.

The Convention on Biological Diversity (CBD) is one of the most important international agreements. The CBD recognises the importance of agricultural ecosystems and biodiversity for food security and sustainable development. It also provides a framework for countries to work together to conserve and sustainably use biodiversity.

Another critical international agreement is the International Plant Protection Convention (IPPC). The IPPC aims to prevent the introduction and spread of pests of plants and plant products. This protects agricultural ecosystems from pests and diseases that heat waves can transport.

The United Nations Convention to Combat Desertification (UNCCD) also addresses some issues related to heatwaves and protecting agricultural ecosystems and biodiversity. The UNCCD aims to combat desertification, land degradation, and drought. This is important because heat waves can contribute to these problems.

In addition to these international agreements, several national laws and regulations address heatwave and the protection of agricultural ecosystems and biodiversity. These laws and regulations vary from country to country, but they often include provisions on things like:

- The management of agricultural land
- The use of water resources
- The control of pests and diseases
- The protection of soil health

The legal perspective on heatwaves and protecting agricultural ecosystems and biodiversity is still evolving. As the impacts of climate change become more severe, there will likely be a need for new laws and regulations to address these issues.

Here are some specific legal actions that can be taken to protect agricultural ecosystems and biodiversity from heat waves:

- **Enforcement of existing laws and regulations:** Countries need to enforce existing laws and regulations that are designed to protect agricultural ecosystems and biodiversity. This includes laws on things like land management, water use, and pest control.
- **Development of new laws and regulations:** Countries may need to develop new laws and regulations to address the specific challenges heat waves pose. These laws and regulations could include things like requirements for heat-tolerant crops, water conservation measures, and pest management plans.
- **Provision of financial and technical assistance:** Countries must provide financial and technical assistance to help farmers and other stakeholders adapt to heat waves. This assistance could be used to support things like developing heat-tolerant crops, installing irrigation systems, and training farmers on pest management.

By taking these legal actions, countries can help to protect agricultural ecosystems and biodiversity from heat waves and ensure that they have a sustainable food supply for the future.

4.3 Sustainable Water Resource Management And Irrigation Practices

Managing water resources sustainably and using irrigation techniques from a legal perspective is a complicated and developing area of law. There are a number of international agreements that deal with these issues, but there isn't one overarching legal framework. The United Nations Convention on the Law of the Non-Navigational Uses of International Watercourses (UN Convention) is among the most crucial international agreements. In recognition of the significance of water resources for sustainable development, the UN Convention establishes a framework for international cooperation in managing shared watercourses (International Centre for Water Security and Sustainable Management, 2019)

The Watercourses Convention is another significant international treaty governing the use and protection of transboundary waterways and lakes. The Watercourses Convention expands on the UN Convention by containing more specific provisions regarding issues like water quality, the preservation of ecosystems, and the avoidance of transboundary water pollution. In addition to these international agreements, several national laws and regulations deal with heat waves, sustainable water resource management, and irrigation techniques (United



Nations, 2022). These rules and laws vary from nation to nation. Still, they frequently contain clauses about the following:

- i. Water resource allocation
- ii. Water is used for irrigation
- iii. Water quality preservation
- iv. Water pollution reduction

Irrigation techniques, sustainable water resource management, and heat waves are all still being explored legally. In order to address these issues, new laws and regulations will probably be required as the effects of climate change worsen. Here are some specific legal actions that can be taken in the context of heatwaves to advance sustainable irrigation and water resource management methods:

- i. Regulation and enforcement of current laws: It is vital for nations to uphold the existing laws and rules that support sustainable irrigation and water resource management. Laws governing water distribution, quality, and pollution are included in this.
- ii. Creating new laws and regulations: To address the unique issues presented by heatwaves, nations may need to create new laws and regulations. Laws and rules governing the use of drought-resistant crops, water-efficient irrigation systems, and requirements for water conservation are just a few examples of the types of things that could be covered.
- iii. Assistance in the form of money and expertise: To aid farmers and other stakeholders in coping with heat waves, countries must offer both financial and expert assistance. This support could be used for things like creating drought-resistant crops, installing water-efficient irrigation systems, and instructing farmers in water conservation.

Countries can support the development of sustainable irrigation and water resource management strategies in the context of heatwaves by pursuing these legal actions and ensuring their own water security in the long run.

In the context of heatwaves, the following examples of specific legal provisions can be used to encourage the use of irrigation and water resource management strategies that are sustainable:

- i. Water allocation laws: These laws can be used to ensure that water is distributed fairly and equitably, considering the needs of all users, including farmers.
- ii. Water quality laws can be used to safeguard the quality of the water supply, particularly during heat waves when it may be more easily harmed.
- iii. Legislation to prevent water pollution: This legislation can be used to stop water pollution, particularly from agricultural sources.
- iv. Irrigation laws: These regulations can be used to encourage the use of water-wise irrigation methods, particularly during heat waves when water supplies are more scarce.

Countries can support sustainable water resource management, and irrigation practises in the context of heatwaves by incorporating these legal provisions into their legal frameworks and ensuring that they have a reliable water supply in the future.

4.4 Initiatives And Agreements Addressing Heatwave Impacts On Food Security

There are a number of initiatives and agreements that address the impacts of heat waves on food security. Some of the most important include:

- i. **The Global Framework for Action on Climate Change and Food Security (GFCS):**
The GFCS is a global framework that aims to help countries adapt to the impacts of climate change on food security. It includes a number of initiatives that address the impacts of heat waves, such as the development of heat-tolerant crops and the promotion of water-efficient irrigation practices.
- ii. **The International Fund for Agricultural Development (IFAD):**
IFAD is an international organisation that provides financial and technical assistance to developing countries. IFAD has a number of programs that address the impacts of heat waves on food security, such as the promotion of climate-smart agriculture and the development of early warning systems.
- iii. **The United Nations Convention to Combat Desertification (UNCCD):**
The UNCCD is an international agreement that aims to combat desertification, land degradation, and drought. The UNCCD has a number of programs that address the impacts of heat waves on food security, such as the promotion of sustainable land management practices and the development of drought-resistant crops.
- iv. **The Food and Agriculture Organization of the United Nations (FAO):**
The FAO is a specialised agency of the United Nations that leads international efforts to defeat hunger. The FAO has a number of programs that address the impacts of heat waves on food security, such as the development of early warning systems and the promotion of climate-smart agriculture.

These are just a few of the many initiatives and agreements that address the impacts of heat waves on food security. These initiatives and agreements are essential because they help raise awareness of the issue, provide financial and technical assistance, and develop solutions to address the challenges of heat waves.

In addition to these initiatives and agreements, a number of other things can be done to address the impacts of heat waves on food security. These include:

- i. **Investing in research and development:** There is a need for more research and development into heat-tolerant crops, water-efficient irrigation practices, and other ways to adapt to the impacts of heat waves.
- ii. **Strengthening early warning systems:** Early warning systems can help farmers prepare for heat waves and reduce crop damage.
- iii. **Promoting climate-smart agriculture:** Climate-smart agriculture is a way of farming that helps reduce climate change's impacts on food security.



- iv. Increasing resilience: Farmers need to be able to adapt to the impacts of heat waves and other climate change impacts. This can be done by diversifying their crops, using water-efficient irrigation practices, and other measures.

By taking these steps, we can help protect food security and ensure everyone has access to safe, nutritious food in the face of heat waves and other climate change impacts.

4.5 Policy Implications For Addressing The Impact Of Heat Waves On Food Security

Policymakers can effectively utilize research findings on the impacts of heat waves on food security to develop regulations and policies that address these challenges. There are several actions to address the impact of heat waves on food security, namely:

1. Acknowledge and understand research findings

Policymakers should review and acknowledge the latest research findings on the impacts of heat waves on food security. This includes studying scientific studies, reports, and assessments conducted by reputable institutions and experts. Understanding the specific impacts of heat waves on crop yields, agricultural practices, and food availability is crucial in formulating appropriate policies.

2. Establish partnerships with research institutions

Policymakers can collaborate with research institutions, universities, and scientific organizations to access relevant research data and expertise. By fostering partnerships, policymakers can enhance their understanding of the complex interactions between heat waves and food security and gain valuable insights into effective policy interventions.

3. Conduct impact assessments

Policymakers should commission impact assessments to evaluate the specific vulnerabilities and risks that heat waves pose to food security within their jurisdiction. These assessments can analyze the local agricultural systems, identify hotspots, and quantify the economic, social, and environmental implications of heatwave impacts. Such assessments provide evidence-based guidance for policymaking.

4. Consult stakeholders

Policymakers should engage with various stakeholders, including farmers, agricultural associations, food producers, consumer groups, and environmental organizations. Consultations enable policymakers to understand the real-world implications of heatwave impacts on food security and consider diverse perspectives in policy formulation. Stakeholders' input can help shape effective regulations and policies that are practical and responsive to local needs.

5. Develop adaptation and resilience strategies

Based on research findings, policymakers can develop adaptation and resilience strategies that address the specific challenges of heat waves on food security. These strategies may include promoting climate-smart agricultural practices, such as water-efficient irrigation, crop

diversification, and agroforestry. They can also encompass measures to enhance post-harvest management, improve storage and distribution systems, and strengthen social safety nets to support vulnerable communities during heatwave-induced food crises.

6. Foster international cooperation

Given the transboundary nature of climate change and heatwave impacts, policymakers should engage in international cooperation and knowledge-sharing platforms. Collaborating with other countries and participating in global initiatives on climate change adaptation and food security can enhance policymakers' access to best practices, lessons learned, and innovative solutions.

By utilizing research findings and following these steps, policymakers can develop evidence-based regulations and policies that effectively address the impacts of heat waves on food security. These measures can contribute to building resilience, ensuring sustainable food production, and protecting vulnerable communities from the adverse effects of heat waves on food availability and access.

CONCLUSION

Climate change and heat waves are inextricably linked, and heat waves severely impact Asian food security. Scientific study has proven that climate change, mainly caused by human activity, is causing global temperatures to rise. This temperature rise increases heat waves' frequency, intensity, and duration. Heat waves have a multifaceted impact on Asian food security. For starters, heat waves can reduce crop yields and productivity. High temperatures can impair photosynthesis, alter plant development patterns, and increase water stress, decreasing agricultural yield and food availability. This can lead to higher food prices and a lack of access to nutritious food, especially for vulnerable populations. Second, heat waves can interrupt livestock's natural breeding cycles and reproductive processes, resulting in decreased animal productivity and potential losses in meat, milk, and other livestock products. This could put more strain on food resources and worsen food poverty. Furthermore, heat waves can raise the danger of pests, illnesses, and alien species damaging crops and negatively impacting food production. Extreme heat can also degrade crop quality and nutritional content, making them unfit for eating or processing.

Asian countries' sensitivity to the effects of heat waves on food security is determined by various factors, including their geographical position, reliance on agriculture, socioeconomic situations, and existing adaptation capacities. Low-income communities and small-scale farmers are frequently the hardest hit because they lack the means, technology, and infrastructure to deal with the challenges posed by heat waves.

Unprecedented heat waves in Asian countries in 2023 were driven mostly by a mix of meteorological and environmental factors. Rising global temperatures owing to climate change, localized weather patterns, geographical factors, and human activities are among these variables. Climate change, fueled by greenhouse gas emissions, has contributed to an overall rise in global temperatures, fostering a climate suitable to heat wave events. Heat



waves can be exacerbated and prolonged by localized weather patterns such as the presence of high-pressure systems or the absence of cooling factors such as rainfall or cloud cover. Landlocked regions or those surrounded by mountains, for example, can trap heat and enhance the severity of heat waves.

Heat waves are extended episodes of extremely high temperatures, frequently accompanied by drought conditions and low rainfall. These extreme weather occurrences, directly and indirectly, affect agricultural systems and food security. Many Asian countries' agricultural sectors are critical to their economies, providing livelihoods for millions of people and contributing to food production. Heat waves can have a significant impact on food security by reducing crop yields and quality, increasing the risk of pests and diseases, and disrupting supply chains. The effects of heat waves can be compounded by other extreme events, such as droughts and floods, which can further reduce the availability of healthy and nutritious food. The impact of heat waves on food security is a complex issue that requires coordinated research and governance to develop resilient food systems that can adapt to extreme events (Mehrabi, 2022)

International environmental law plays a crucial role in addressing heatwave impacts by providing a framework for cooperation and action at the global level. However, there are still many challenges and limitations to overcome. It is up to all of us to take action, whether as individuals, communities, or nations, to reduce greenhouse gas emissions, promote renewable energy sources, and develop adaptation measures to protect ourselves and our planet from the devastating impacts of heat waves. Therefore, the findings of this paper may indirectly contribute to discussions on food security and the need for coordinated responses to address the impacts of climate change.

Heat waves are a serious threat to food security around the world, but there are measures that can be taken to mitigate their effects. By improving agricultural practices, investing in climate-smart technologies, and supporting vulnerable populations, we can help ensure a more sustainable and secure food system for all. It is up to us to take action and address this urgent issue. Our call to action is simple, we must all do our part to reduce greenhouse gas emissions and promote sustainable development. Whether it's through individual actions like reducing meat consumption or supporting policies that prioritize renewable energy, we can all make a difference in creating a more resilient and equitable future for all.

REFERENCES

- Alisher Mirzabaev, Rachel Bezner Kerr, Toshihiro Hasegawa, Prajal Pradhan, Anita Wreford, Maria Cristina Tirado von der Pahlen, Helen Gurney-Smith (2023). “**Severe climate change risks to food security and nutrition, *Climate Risk Management***”, 39, 100473, ISSN 2212-0963,
- Benoit Mayer. (2023). “Climate Change Mitigation as an Obligation under Customary International Law”. ***Yale Journal of International Law***, 48(1).
- Boqi Liu, Congwen Zhu, Shuangmei Ma, Yuhan Yan, Ning Jian (2023). “Subseasonal processes of triple extreme heat waves over the Yangtze River Valley in 2022”, ***Weather and Climate Extremes***, 40, 100572, ISSN 2212-0947

Accounting Inquiries with New Approaches in the Post-Pandemic Era
Volume I

- Chi Hui Lin, Severe heat wave engulfs Asia causing deaths and forcing schools to close <https://www.theguardian.com/weather/2023/apr/19/severe-heatwave-asia-deaths-schools-close-india-china> (2023)
- Chisanga, Bwalya, Charles et al. (2022). “Modelling climatic trends for the Zambezi and Orange River Basins: implications on water security”. <https://scite.ai/reports/10.2166/wcc.2022.308>
- F. (n.d.). Publication preview page | FAO | Food and Agriculture Organization of the United Nations. Retrieved from <https://www.fao.org/documents/card/en?details=cb3673en/>
- Global Report on Food Crises - 2021 | World Food Programme. (2021, May 5). Retrieved from <https://www.wfp.org/publications/global-report-food-crises-2021>
- Grusson, Y., & Barron, J.. (2022, September 19). Challenges in reanalysis products to assess extreme weather impacts on agriculture: Study case in southern Sweden. **Plos Climate**, 1(9), e0000063. <https://doi.org/10.1371/journal.pclm.0000063>
- Haile, B., Signorelli, S., Azzarri, C., & Johnson, T. P.. (2018, November 28). Welfare effects of weather variability: Multi-country evidence from Africa south of the Sahara. <https://scite.ai/reports/10.1371/journal.pone.0206415>
- Hubbard, Allen et al. (2018, October 26). Identifying mechanisms of regulation to model carbon flux during heat stress and generate testable hypotheses. **Plos One**, 13(10), e0205824. <https://doi.org/10.1371/journal.pone.0205824>
- Kadzere, C.. (2018, October 9). Environmentally smart animal agriculture and integrated advisory services ameliorate the negative effects of climate change on production. <https://scite.ai/reports/10.4314/sajas.v48i5.5>
- Kroeger, C., & Reeves, A. (2022), Extreme heat leads to short- and long-term food insecurity with serious consequences for health, **European Journal of Public Health** (Vol. 32, Issue 4). <https://doi.org/10.1093/eurpub/ckac080>
- Kumari, S., George, S. G., Meshram, M. R., Esther, D. B., & Kumar, P.. (2020, December 31). A Review on Climate Change and its Impact on Agriculture in India. **Current Journal of Applied Science and Technology**, 58-74. <https://doi.org/10.9734/cjast/2020/v39i4431152>
- L. Rickards, S.M. Howden, Transformational adaptation: agriculture and climate change, **Crop Pasture Sci**, 63 (3) (2012), pp. 240-250, 10.1071/CP11172
- Mahreen, Naima et al. (2023, January 23). Mitigation of water scarcity with sustained growth of Rice by plant growth promoting bacteria. <https://scite.ai/reports/10.3389/fpls.2023.1081537>
- Marx, W., Haunschild, R., & Bornmann, L. (2021), “Heat waves: a hot topic in climate change research. Theoretical and Applied Climatology”, 146 (1–2). <https://doi.org/10.1007/s00704-021-03758-y>
- Muthee, Kennedy et al. (2022). “A quantitative appraisal of selected agroforestry studies in the Sub-Saharan Africa”, *Heliyon*, 8(9), e10670. <https://doi.org/10.1016/j.heliyon.2022.e10670>
- N. Subash, Debashis Dutta, P.C. Ghasal, P. Punia, Vinay Prasad Mandal, Brahmadrut, Ved Prakash Chaudhary, Relevance of climatological information on spatial and temporal variability of Indian Summer monsoon rainfall (ISMR) in recent El Nino years and its impact on four important kharif crops over India, **Climate Services**, Volume 30, 2023, 100370, ISSN 2405-8807, <https://doi.org/10.1016/j.cliser.2023.100370>.
- P. Dhanya, A. Ramachandran (2016), “Farmers’ perceptions of climate change and the proposed agriculture adaptation strategies in a semi arid region of south India”, **J. Integr. Environ. Sci.**, 13 (1), 1-18, 10.1080/1943815X.2015.1062031
- Prathap, P., Chauhan, S. S., Leury, B. J., Cottrell, J. J., & Dunshea, F. R.. (2021). “Towards Sustainable Livestock Production: Estimation of Methane Emissions and Dietary Interventions for Mitigation”. <https://scite.ai/reports/10.3390/su13116081>
- Pritha Datta, Bhagirath Behera, Dil Bahadur Rahut, Climate change and Indian agriculture: A systematic review of farmers’ perception, adaptation, and transformation, **Environmental Challenges**, Volume 8, 2022, 100543, ISSN 2667-0100,
- Puley, G. (2022). “Extreme Heat”. <https://www.ifrc.org/sites/default/files/2022-10/Extreme-Heat-Report-IFRC-OCHA-2022.pdf>
- Ranjamani, L., Peel J. (2021). **The Oxford Handbook of International Environmental Law**. In *The Oxford Handbook of International Environmental Law* (2nd). <https://doi.org/10.1093/law/9780198849155.001.0001>
- Sanober, N. (2023). “An overview of the influence of climate change on food security and human health.” **Archives of Food and Nutritional Science**, 7(1). <https://doi.org/10.29328/journal.afns.1001044>
- Sharma, A., Andhikaputra, G., & Wang, Y. C. (2022). “Heat waves in South Asia: Characterization, Consequences on Human Health, and Adaptation Strategies”, **Atmosphere** 13(5). <https://doi.org/10.3390/atmos13050734>
- Xinbo Lian, Jianping Huang, Han Li, Yongli He, Zhi Ouyang, Songbo Fu, Yingjie Zhao, Danfeng Wang, Rui Wang, Xiaodan Guan (2023). “Heat waves accelerate the spread of infectious diseases, *Environmental Research*”, 231(2), 116090, ISSN 0013-9351



Zhang, Yan et al. (2021). “Functional analysis of tomato CHIP ubiquitin E3 ligase in heat tolerance”.
<https://scite.ai/reports/10.1038/s41598-021-81372-8>

Zia Mehrabi, Ruth Delzeit, Adriana Ignaciuk, Christian Levers, Ginni Braich, Kushank Bajaj, Araba Amo-Aidoo, Weston Anderson, Roland A. Balgah, Tim G. Benton, Martin M. Chari, Erle C. Ellis, Narcisse Z. Gahi, Franziska Gaupp, Lucas A. Garibaldi, James S. Gerber, Cecile M. Godde, Ingo Grass, Tobias Heimann, Mark Hirons, Gerrit Hoogenboom, Meha Jain, Dana James, David Makowski, Blessing Masamha, Sisi Meng, Sathaporn Monprapussorn, Daniel Müller, Andrew Nelson, Nathaniel K. Newlands, Frederik Noack, MaryLucy Oronje, Colin Raymond, Markus Reichstein, Loren H. Rieseberg, Jose M. Rodriguez-Llanes, Todd Rosenstock, Pedram Rowhani, Ali Sarhadi, Ralf Seppelt, Balsher S. Sidhu, Sieglinde Snapp, Tammara Soma, Adam H. Sparks, Louise Teh, Michelle Tigchelaar, Martha M. Vogel, Paul C. West, Hannah Wittman, Liangzhi You (2022). “**Research priorities for global food security under extreme events, One Earth**”, 5(7), 756-766, ISSN 2590-3322

EDITORS' BIOGRAPHIES

Assoc. Prof. Dr. Muhammad Ali TARAR (Ph. D Rural Sociology)

Dr. Muhammad Ali Tarar joined University of Agriculture, Faisalabad- Pakistan as Teaching Assistant in 2005, later as, Lecturer Rural Sociology in November 2007 and presently serving the Department of Sociology, Ghazi University, Dera Ghazi Khan-Pakistan as Associate Professor / Chairman Sociology. Additionally, he is also serving as Director, Financial Assistance & Development (FAD) at Ghazi University D.G.Khan w.e.f 05-07-2023 to provide Financial Support in the form of Merit & Need based Scholarships/ paid Internships and Financial Assistance to talented, deserving & needy students to continue their academics & Education. Since 18-11-2015 to 24-10-2022 also served as Director Office of Research, Innovation & Commercialization (ORIC) and awarded a “Certificate of Appreciation” from Vice Chancellor, Ghazi University, Dera Ghazi Khan for excellent services (15-09-2022). As Chief Editor, Kisht-e-Nau (student Magazine, University of Agriculture, Faisalabad) published Centennial Number in 2006 and was awarded UNIVERSITY GOLD MEDAL from Chancellor of University/ Governor of Punjab-Pakistan as-well-as UNIVERSITY ROLE OF HONOR, UNIVERSITY COLOUR & UNIVERSITY CERTIFICATE OF EXCELLENCE was awarded from Worthy Vice Chancellor for publishing the Centennial Number of “ Kisht-e-Nau “ as Chief Editor on the eve of centenary celebrations of University of Agriculture, Faisalabad (14th to 16th March 2006). He has vast experience in teaching & research. Being Researcher published more than 40 research articles on different social & behavioral issues in National & International high-quality indexes/ impact factor journals that are recognized by Higher Education of Pakistan and at postgraduate level supervised more than one hundred research students and completed their research. He is also coauthor/ Editor of books (i)“Introduction to Sociology; (ii) “Accounting Inquiries with New Approaches in the Post-Pandemic Era Volume I”; (iii) “Accounting Inquiries with New Approaches in the Post-Pandemic Era Volume II”; (iv) “Abstract E-Book” 5th International CEO Social Sciences Congress (CEOSSC 2022)”. He is also external examiner of research / paper setter of many universities for postgraduate level as well as examination supervisor of Punjab Public Service Commission, Pakistan. Being Director ORIC made collaboration with sister universities and industries to develop academia to academia & Academia-Industry linkages for better knowledge and research sharing and signed more than 20 MOUs and strengthen the external linkages, developed a Business Incubation Center (Regional Plan9) & Women Development Center at Ghazi University with collaboration of Govt. of Punjab, Pakistan. He is Member selection/ recommendation Committee of Ghazi University to recommend BS-1 to BS-16 candidates to the Vice Chancellor for Approval of Appointment, Terms, and conditions of Services); Member Board of Faculty for a period of three years for faculty of Arts; Member Consultative Committee; Member Convocation Organizing Committee for 1st & 2nd Convocation of the Ghazi University; Convener University Disciplinary Committee ; Convener University Disciplinary Advisory Committee; Member Compliance Implementation Plan Committee (CIPC) to prepare Compliance Implementation Plan (CIP) in coordination with respective offices; Nominated as Focal Person to collaborate with QEC regarding IPE



Review visit at Ghazi University; Member Affiliation Committee (to affiliate & Disaffiliate Govt. & Private Educational Institutes / colleges with Ghazi University); Member University Grievance Redress Committee; Member University Monitoring, Evaluation and Learning Committee; Member University Scrutiny Committee for Administration Posts; Member Standing Committee for vetting of non-schedule items with the term of Reference (TORs); Member Surveillance committee of Ghazi University; Member Online Quality Assurance (OQA) Task Force of Ghazi University; Members University General Purchase Committee; Member University Semester Rules Committee; Member Inquire committee about matter/ issue regarding allegations on social & print media against employees, Member University Prospectus Committee to prepare prospectus and Member University Admission Committee year 2019, 2020 & 2021; Focal Person Kamyab Jawan Innovation League; Member Plagiarism Standing Committee (PSC) Ghazi University; Member Self Institutional Performance Evaluation (IPE) Committee and Focal person to conduct quantitative research on Beggary in Punjab with collaboration of Department of Social Welfare, UC DP, D. G. Khan (December 2016 to To-date).

Dr. Muhammad Ali Tarar, Associate Professor Department of Sociology,
Director, Financial Assistance & Development (FAD)
Ghazi University, Dera Ghazi Khan
alitarar2000@yahoo.com

Assoc Prof. Dr. Sevda Aghamirza Aliyeva (Ahadova)

Assoc. Prof. Dr. Sevda Aghamirza Aliyeva (Ahadova) was born in Baku, Azerbaijan in 1975. Dr. of sciences (in political science), Phd (philological science) in 2008, Assoc. Prof Dr. in 2015, joined University of Languages of Azerbaijan Republic (department of international relations). Assoc Prof. Dr. The Academy of Public Adminstration under the President of the Republic of Azerbaijan (department of political sciences).

Participant of so many national and international Congresses. "Culture and Civilization Unity of Contradictions" Kazakhstan 2013. " The Interrelation of cultures" Ukraine, Kiev. 2014. "Culture and Civilization. American journal of international law. Impact factor 2015. " Modern Azerbaijan Society and the problems of Multiculturalizm" International Conference of European Science and Technology. Munich 2015. " Modern problems of Intercultural communication". Moscow 2013. " Azerbaijan- Belarus Relations; Main stages of development and current situation" Belarus 2022. " Azerbaijan Gender Inequality in the Republic of Azerbaijan. CEO Conference 2022 which is held in Indonesia.

She has experienced in teaching at the University and research. Being a researcher she published more than 70 research articles on different social and behavioral issues in National and International high quality indexes, impact factor journals. According inquiries with new approaches, in the post pandemic days: Abstract E book, 4th International CEO Social Sciences Congress[GEOSSC] 2022.

She is on the academic boards of national and international congresses. International CEO Congress is one of these. Recently, she has been working on book publications. This book you are reading is the product of these studies.



Doğrulama Kodu : f70b63cb-4c05-4132-bec8-804f1f8a5950

**T.C.
KÜLTÜR VE TURİZM BAKANLIĞI**



SERTİFİKA

FİRMA ADI : NCM MİMARLIK MÜHENDİSLİK İNŞ. SAN. TAAH. TİC. LTD. ŞTİ.
ADRESİ : ESENTEPE MAHALLESİ GÜVERCİN(160) SOKAK ŞENOCAK APARTMANI 2A
NİLÜFER/BURSA NİLÜFER / BURSA
VERGİ DAİRESİ : NİLÜFER VERGİ DAİRESİ MÜD.
VERGİ NUMARASI : 6270313993
FAALİYET ALANI : DAĞITIM (KİTAP, MÜZİK VB), İTHALAT, SATIŞ, YAYINEVİ
VERİLİŞ NEDENİ - TARİHİ : Yeni Sertifika Başvurusu - 30.07.2021

İş bu sertifika açık unvan ve adresi yazılı olan işyeri, 5846 sayılı Fikir ve Sanat Eserleri kanunu uyarınca yukarıda belirlenen alan/alanlara ilişkin faaliyet gösterir.

SERTİFİKA NO
51898

GEÇERLİLİK TARİHİ
30.07.2021 - 30.07.2025

e-imzalıdır
Dr. Kamil ÖZER
Vali a.
İl Müdürü